

OPERATING AND MAINTENANCE MANUAL FOR ELECTRIC BOOSTER HEATER

HubbellTM ELECTRIC HEATER COMPANY

BASE MODEL “J”



CFESA
Commercial Food Equipment Service Association

NAFEM
North American Association of
Food Equipment Manufacturers

AutoQuotes



2010 Edition



ASSOCIATE MEMBER
MAFSI
Manufacturers' Agents for
the Food Service Industry

ISO 9001:2008 ISO



ASME



ANSI/NSF5

**HUBBELL
ELECTRIC HEATER COMPANY
45 SEYMOUR STREET
P.O. BOX 288
STRATFORD, CT 06615**

**PHONE: (203) 378-2659
FAX: (203) 378-3593
INTERNET: <http://www.hubbellheaters.com>**

-- IMPORTANT --

Always reference the full model number and serial number when calling the factory.

WARNING / CAUTION

1. Tank is to be completely filled with water and all air is to be vented before energizing.
2. Due to the rigors of transportation, all connections should be checked for tightness before heater is placed in operation.
3. Safety relief valve must be installed in tapping provided.
4. The refractory material used in heating elements may absorb some moisture during transit, periods of storage, or when subjected to a humid environment. This moisture absorption results in a cold insulation resistance of less than twenty (20) megohms. If this heater has been subjected to the above condition, each heating element must be checked for insulation resistance before energizing. Contact the factory for a replacement element.
5. **KEEP AWAY FROM LIVE ELECTRICAL CIRCUITS.**
Do not perform any maintenance, make any adjustments, or replace any components inside the control panel with the high voltage power supply turned on. Under certain circumstances, dangerous potentials may exist even when the power supply is off. To avoid casualties, always turn the power supply safety switch to off, turn the charge or ground the circuit before performing any maintenance or adjustment procedure.
6. The unit is designed to operate at pressure not more than 150 psi.
7. Generalized instructions and procedures cannot anticipate all situations. For this reason, only qualified installers should perform the installations. A qualified installer is a person who has licensed training and a working knowledge of the applicable codes, tools, equipment, and methods necessary for safe installation of an electric resistance water heater. If questions regarding installation arise, check your local plumbing and electrical inspectors for proper procedures and codes. If you cannot obtain the required information, contact the company.
8. **Water Quality Requirements** – Recommended water hardness is 4 to 6 grains of hardness per gallon (GPG). Water hardness above 6 GPG should be treated by a water conditioner (water softener or in-line treatment). Water hardness below 4 GPG also requires treatment to reduce potential corrosion. Excessive GPG will result in higher operating and maintenance costs and will reduce product longevity. Chlorides must not exceed 50 parts per million (ppm). Excessive chlorides will result in metallic corrosion and will reduce product longevity. Water treatment has been shown to reduce costs associated with de-liming the booster as well as reducing metallic corrosion. Product failure caused by these conditions is not covered under warranty. See warranty for complete details.
9. This water heater is not intended for space heating applications.
10. The water heater is factory set at 185°F for booster water heating applications. This results in the possibility of a scalding water injury. A full thickness skin burn can occur in less than one second of exposure to water at this temperature.

TABLE OF CONTENTS

SECTION	TITLE	PAGE No.
I	GENERAL DESCRIPTION AND CONSTRUCTION	4
II	INSTALLATION AND START-UP	9
III	SCHEDULED MAINTENANCE AND OPERATION	24
IV	TROUBLESHOOTING	26
V	SERVICING AND REPLACEMENT OF PARTS	32
VI	SERVICE PARTS LIST	35
VII	TORQUE VALUES	37
VIII	WARRANTY INFORMATION	38

SECTION I - GENERAL DESCRIPTION AND CONSTRUCTION

GENERAL DESCRIPTION

This book describes a packaged electric booster heater that is typically used to provide 180°F sanitizing rinse water. The complete assembly consists of the storage tank, immersion electric heating element(s), electronic control module, safety relief valve, magnetic contactor(s), and any other required electrical operating control. Optional equipment may be supplied with your unit. Please consult the product packing list for details specific to your assembly. The unit is factory assembled, insulated, jacketed, wired, tested, and ready for electrical and plumbing service connections.

CAPACITY

Model	Storage Capacity (gallons)	kW	40°F Rise (GPH)	70°F Rise (GPH)	Model	Storage Capacity (gallons)	kW	40°F Rise (GPH)	70°F Rise (GPH)
J32.9	3	2.9	30	17	J161	16	1	10	5
J35.7	3	5.7	58	33	J161.5	16	1.5	15	8
J39.9	3	9.9	101	58	J162	16	2	20	11
J310.4	3	10.4	107	61	J163	16	3	30	17
J311.4	3	11.4	117	67	J164	16	4	41	23
J411	4	11.4	117	67	J166	16	6	62	35
J415	4	15	154	88	J167	16	7	72	41
J427	4	27	277	158	J169	16	9	92	53
J61	6	1	10	5	J1612	16	12	123	70
J61.5	6	1.5	15	8	J1613	16	13.5	138	79
J62	6	2	20	11	J1615	16	15	154	88
J63	6	3	30	17	J1618	16	18	185	105
J64	6	4	41	23	J1624	16	24	246	141
J65	6	5	51	29	J1627	16	27	277	158
J66	6	6	62	35	J1630	16	30	308	176
J67	6	7	72	41	J1636	16	36	369	211
J69	6	9	92	53	J1639	16	39	400	228
J610	6	10.5	108	62	J1640	16	40.5	415	237
J612	6	12	123	70	J1645	16	45	461	264
J613	6	13.5	138	79	J1654	16	54	554	316
J615	6	15	154	88	J1658	16	58.5	600	343
J618	6	18	185	105	J1664	16	64	656	375
J624	6	24	246	141	J1666	16	66	677	387
J627	6	27	277	158	J1668	16	68	697	398
J630	6	30	308	176	J1679	16	79	810	463
J636	6	36	369	211	J1681	16	81	830	474
J639	6	39	400	228	J1685	16	85	871	498
J640	6	40.5	415	237	J1686	16	86	882	504
J645	6	45	461	264	J1688	16	88	902	515
J654	6	54	554	316	J1690	16	90	923	527
J658	6	58.5	600	343					

MODEL **J6** - (1 TO 18 kW) DIMENSIONS



Shipping Weight: 95 lbs.

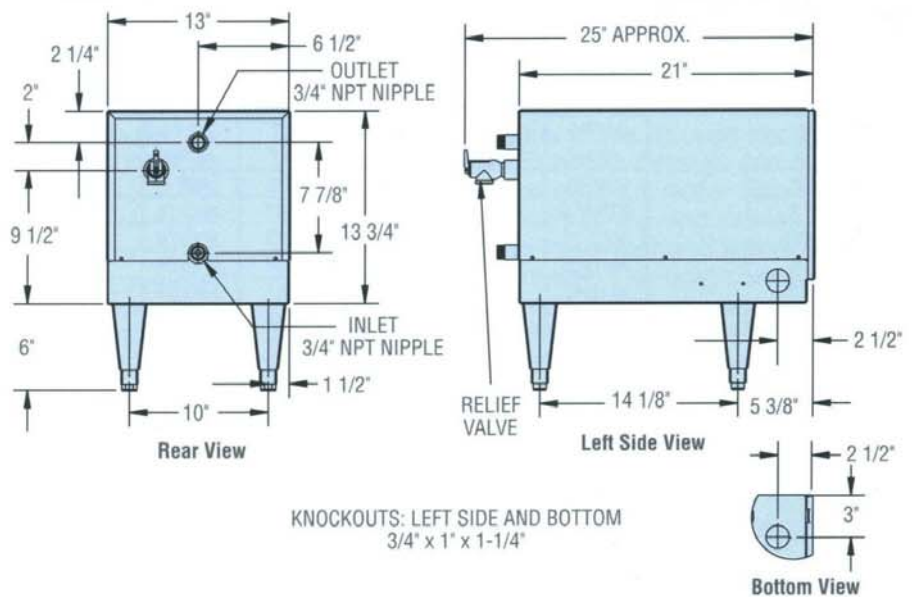

MODEL **J6** - (24 TO 58 kW) DIMENSIONS



Shipping Weight: 110 lbs.

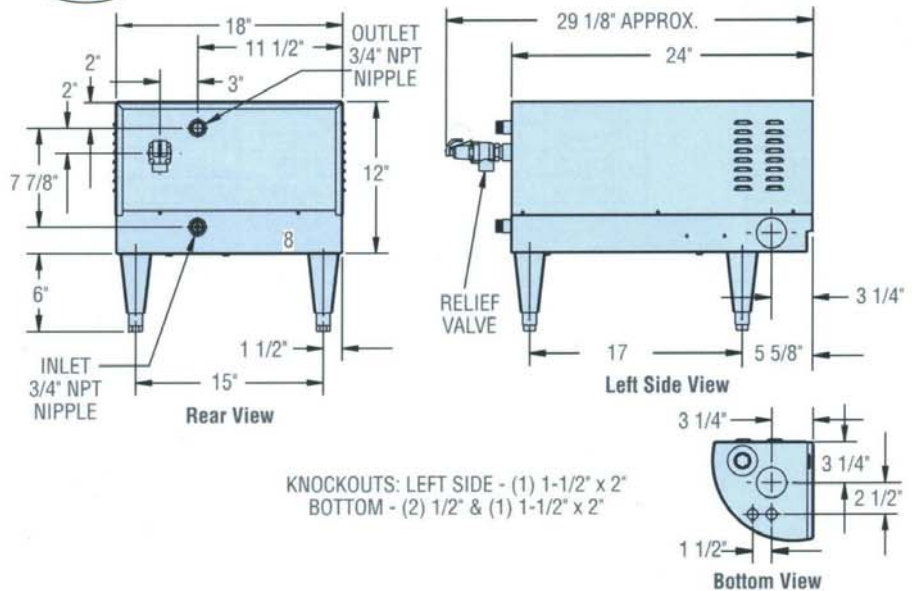

MODEL **J16** - (1 TO 58 kW) DIMENSIONS



Shipping Weight: 180 lbs.

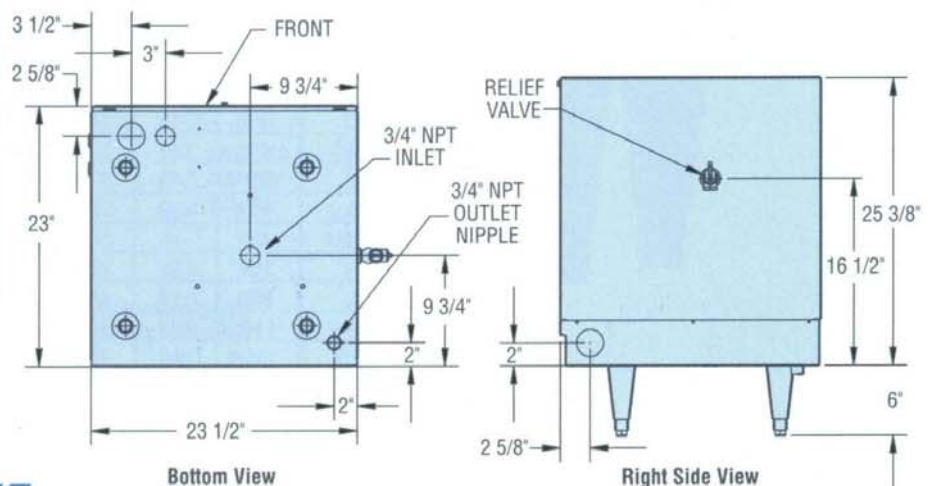

Hubbell™

MODEL J16 - (64 TO 90 kW) DIMENSIONS



Shipping Weight: 180 lbs.

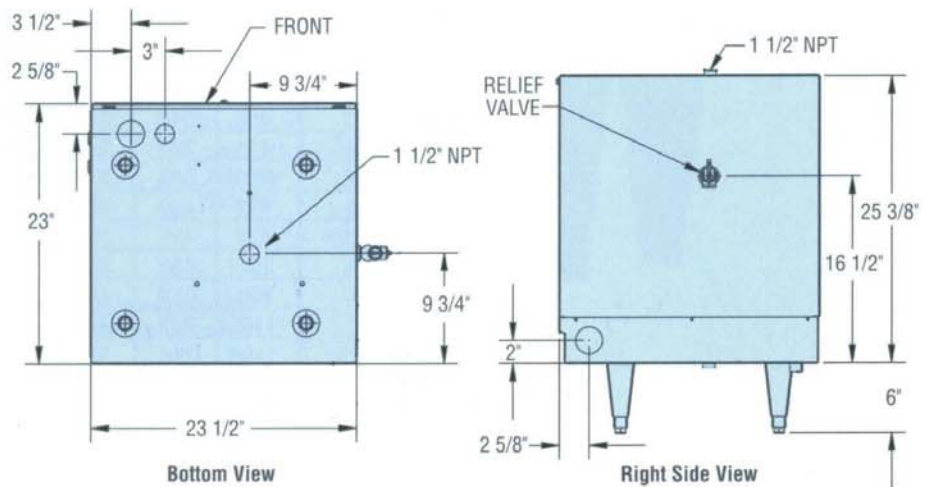

KNOCKOUTS: LEFT SIDE - 1-1/2" x 2"
 BOTTOM - 1-1/2" x 2" & 3/4" x 1" x 1-1/4"

MODEL J3 - DIMENSIONS



Shipping Weight: 46 lbs.
 Note: Shown with Optional Legs

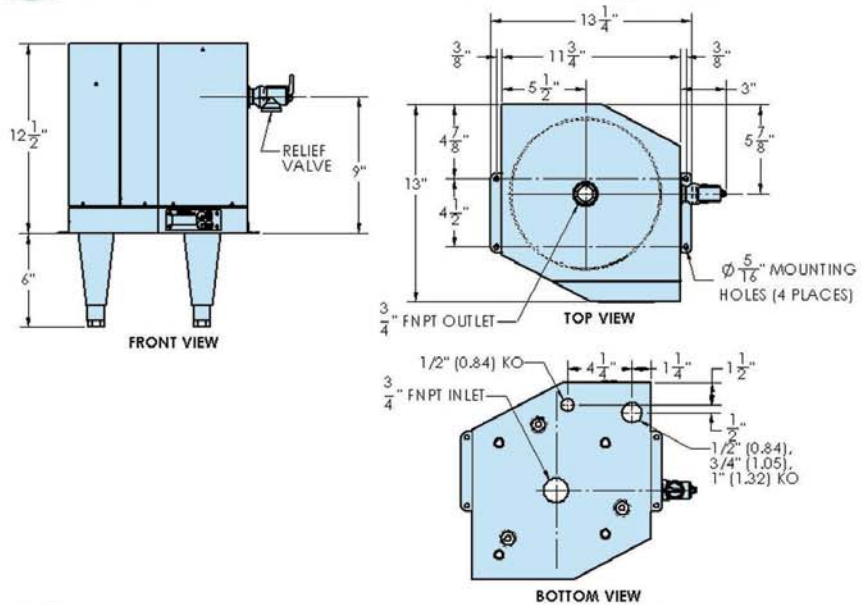

MODEL J4 DIMENSIONS



Shipping Weight: 80 lbs.
 Note: Shown with Optional Legs

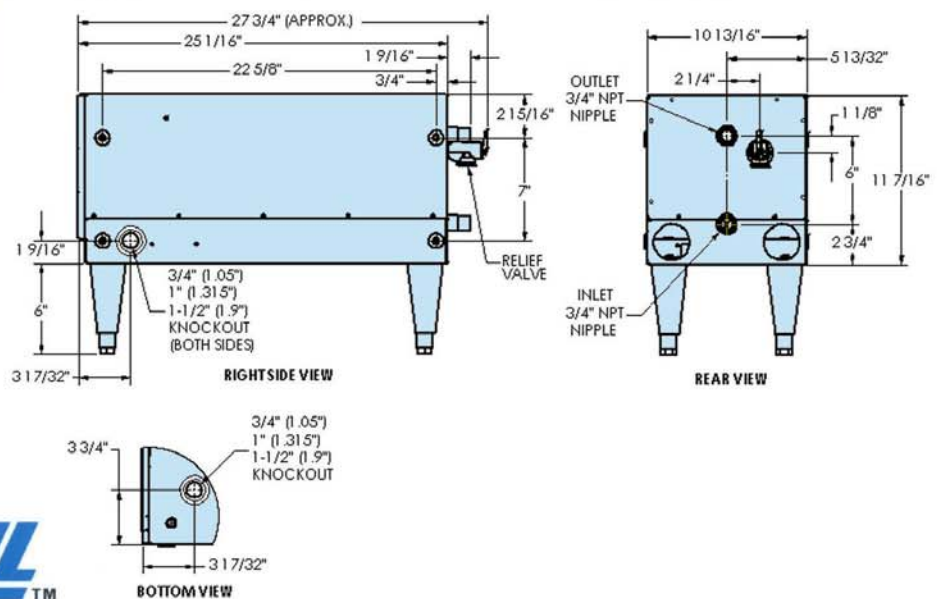

Hubbell™

CONSTRUCTION

TANK

The storage tank is designed, manufactured, and stamped in accordance with ASME section VIII Division 1. The tank is constructed of type 304L stainless steel for maximum tank longevity and fabricated by all welded construction and is designed for a maximum allowable working pressure of 150 psi (225 psi TP).

TANK CONNECTIONS

The heater is supplied with separate connections for the cold/warm inlet and the hot water outlet. Water entering the warm water inlet and leaving through the hot water outlet is evenly circulated by means of a diffuser within the tank. A ¾-inch FNPT connection is provided for mounting a combination safety temperature and pressure relief valve. An overflow line should be utilized from the relief valve outlet to a floor drain. See drawing for locations and sizes.

HEATING ELEMENT

The water heater is supplied with an electric immersion heating element assembly(s), composed of copper sheathed elements that are fitted into a brass 1½-12UNF screw plug with 1-7/8" hex. Each assembly is threaded into the tank and sealed with an o-ring gasket. See drawing for voltage and power ratings. Note that the J3 model element is a 1" NPS thread with a 1 ½" hex.



MAGNETIC CONTACTOR

The definite purpose magnetic contactor(s) is a heavy-duty resistive load type. The contactor supplies power to the heating element(s) based on the resistive load (non-inductive) of the heater only when the relay on the control board is closed, thereby pulling in the contacts until the desired temperature is reached. At this point, the contacts will drop out, which in turn disconnects power from the elements. Units with two contactors will turn on and off in stages.



CONTROL BOARD AND DISPLAY

The control board supplies all the necessary function for heater operation. These include control temperature, hi-limit cut-out, low water detection, and leak detection.



LOW VOLTAGE CONTROL TRANSFORMER

A control circuit transformer is supplied with all models rated greater than 240-volts. This component is used to step down the primary power supply (600, 480, 440, 415, 380, or 277) to 208/240-volts for safety when working with control circuits.



POWER CIRCUIT BREAKERS

When required by code, a magnetic power circuit breaker is supplied for circuit overload protection. The circuit breaker can be reset in the event of a current overload.



OUTER SHELL, INSULATION, AND SUPPORTS

The tank is encapsulated in high efficiency foam insulation meeting the requirements for UL 94 HF-1 rating. The protective shell is constructed of type 304 brushed stainless steel. NSF approved adjustable plastic legs are provided for support. Plastic legs for the J3 and J4 models are optional.

DIAL TEMPERATURE AND PRESSURE GAUGE

A combination temperature (30°-240° F / 0°-120°C) and pressure (0-200 psi / 0-1400 kPa) gauge with 3-inch dial is supplied with the unit for in-line installation (shipped loose). The connection is ½" NPT with a 2" long sensing probe. Dial temperature and pressure gauges for the J3 and J4 models are optional.



PRESSURE REDUCING VALVE

A bronze pressure reducing valve with built-in bypass is supplied with the unit. This valve is shipped separately for in-line installation. The 3/4" NPT valve is adjustable from 25-psi to 75-psi. The inlet connection is supplied with a 3/4" union by sweat connection. The outlet connection is 3/4" female NPT. The set screw located at the top of the diaphragm adjusts the pressure, turn clockwise to decrease the pressure and counter-clockwise to increase the pressure. Pressure reducing valves for the J3 and J4 models are optional.



DIELECTRIC UNIONS

Dielectric unions are provided for the inlet and outlet nipples to isolate stray ground currents to reduce the possibility of galvanic corrosion. (Optional on the J3 and J4 Models).

OPTIONAL EQUIPMENT

Slide Brackets

Available for the J6 Model only, these brackets allow for mounting the booster heater under a counter. See slide bracket diagram on page 9 for details.

Shock Absorber

The optional shock absorber can be installed between the booster and the dishwasher to reduce the harmful pressures resulting from quick closing dishwasher solenoid valves.



Legs

In lieu of the standard black plastic legs, optional adjustable legs are available in stainless steel, die-cast nickel plated, and floor mount stainless steel. All optional legs are adjustable height type.



Floor Mount

Nickel Plated

Stainless Steel

Security Package

For prison and other secure facilities a tamper resistant package is available. All external screws are spader type requiring a spader wrench for removal.

Alternate Voltage

Other voltages are available, including 277V single-phase, and 380V, 415V, and 440V three-phase. Consult the factory for details.

Water Treatment System

The optional water treatment system provides superior mineral scale prevention and corrosion control by feeding a special blend of scale control compounds into the warm water stream before the heater. The in-line system includes a clear cartridge housing to allow an operator to view the cartridge and determine when it needs replacement without the need to open the system.



XB1 Low Temperature Interlock

An optional in-line control board with separate manual setpoint (range: 165°F – 194°F) monitors the temperature of the water through the P65 probe and will trip a SPDT relay for customers' remote applications.

Remote Alarm Plug Adapter

An optional plug adapter is available to provide a remote fault alarm signal through the J4 connector on the control board. See page 12 for installation details.



24-Volt Heater Interlock Adapter

An optional plug adapter is available to interlock the heater via a 24-volt signal through the J1 connector on the control board. The 24-volt heater interlock adapter is supplied standard on the J3 model. See page 13 for installation details. (Only available with r23 or later software).



Protective Shrouds (J6 and J16 only)

An optional durable protective plastic shroud is available to prevent damage to the booster due to water intrusion. The cover fits snugly over the entire booster and can be easily removed for cleaning and service.



SECTION II – INSTALLATION AND START-UP

WARNING / CAUTION

- DO NOT TURN ON THE ELECTRIC POWER SUPPLY to this equipment until heater is completely filled with water and all air has been released. *If the heater is NOT filled with water when the power is turned on, the heating elements will burn out.*
- For protection against excessive pressures and temperatures, local codes require the installation of a temperature-and-pressure (T&P) relief valve certified by a nationally recognized laboratory that maintains periodic inspection of production of listed equipment of materials, as meeting the requirements for Relief Valves and Automatic Gas Shutoff for Hot Water Supply Systems. ANSI Z21.22-1971. THE CUSTOMER IS RESPONSIBLE TO PROTECT PROPERTY AND PERSONNEL FROM HARM WHEN THE VALVE FUNCTIONS.
- All water heaters have a risk of leakage at some unpredictable time. IT IS THE CUSTOMER'S RESPONSIBILITY TO PROVIDE A CATCH PAN OR OTHER ADEQUATE MEANS, SO THAT THE RESULTANT FLOW OF WATER WILL NOT DAMAGE FURNISHINGS OR PROPERTY.
- Installation or service of this unit requires ability equal to that of a licensed tradesman in the field.
- The installation must conform to these instructions and any local authority having jurisdiction. Grounding and electrical wiring connected to the unit must also conform to the latest version of the National Electric Code NFPA-70.

WATER HEATER PLACEMENT

NOTE: For most effective operation, install the booster heater as close as possible to the dishwasher. If the distance between the booster and the dishwasher exceeds NSF requirements, recirculation methods must be employed.

1. Place the heater on a solid, level foundation in a clean, dry location as near as possible to the dish washing machine.
2. The water heater should be protected from freezing and waterlines insulated to reduce energy and water waste.
3. Leave a minimum of 18" clearance for element withdrawal and control access.
4. Do not install in an area where flammable liquids or combustible vapors are present.

SLIDE BRACKETS FOR HANGING SUPPORT MOUNTING

1. Weld slide rails to bottom of dishtable. Spacing should be 17" for J6 models up to 18kW and 22" for J6 models 24 to 58.5kW. J16 models are not designed for use with slide brackets.

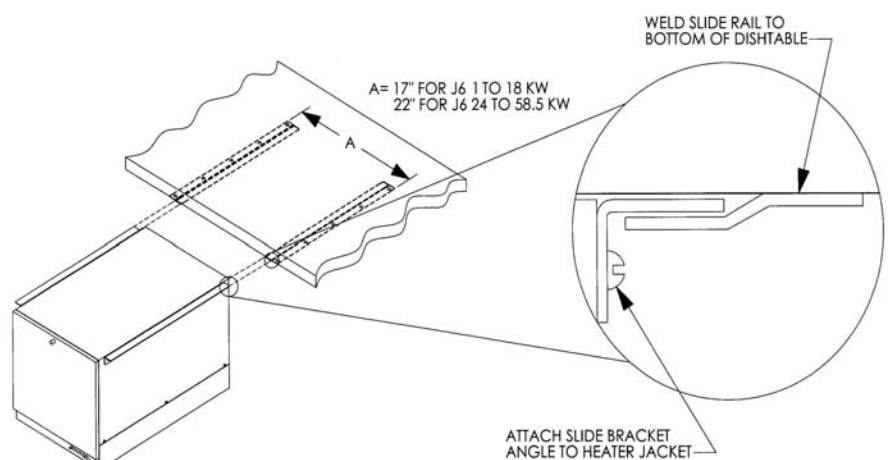

2. Attach slide bracket angles to heater with #8 sheet metal screws. It will be necessary to drill 1/8" holes into heater jacket for screw pilot holes.
3. Slide heater onto slide rails under dishtable.

PIPING INSTALLATION – See Diagrams

NOTES:

- No check valve may be installed in the supply line to the booster.
- All shut-off valves must be gate or ball valves – not globe valves.
- To minimize heat loss and maximize efficiency, hot water piping should be insulated.
- Teflon tape should be used on all NPT threaded pipe connections.

1. Install the factory supplied dielectric unions on the inlet and outlet piping.
2. Connect the cold/warm water inlet and hot water outlet to the appropriate connections as shown; refer to the specifications for location and sizes.

IMPORTANT – Be certain to connect the outlet piping to the final rinse and not to the wash tank.

IMPORTANT (applies to J6 Models only) – Do not turn the entering warm water or exiting hot water nipples from their factory installed positions. The internal diffusers are aligned at the factory and turning the nipple will change the diffuser position and affect performance. Hubbell recommends that the inlet and outlet pipes are insulated to prevent excessive heat loss.

IMPORTANT (applies to J6 Models only) – Do not apply heat directly to the entering warm water or exiting hot water nipples. If sweat connections are to be used, sweat tubing to the adapter before threading the adapter to the nipple on the heater. Any heat applied to the heater nipple will damage the internal plastic diffuser and affect performance.

3. Install water pressure regulator in the entering cold/warm water inlet line and adjust to the pressure recommended by the dishwasher manufacturer. **WHEN A STANDARD PRESSURE REGULATOR IS USED**, (other than that purchased with the booster), it acts as a check valve and it is possible that thermal expansion will cause the relief valve to drip or occasionally blow off a small amount of water. To overcome this condition, it is recommended that a 3/8" by-pass arrangement with a horizontal check valve be installed around the pressure regulator. This will prevent annoyance caused by the relief valve dripping or blowing off. The pressure reducing valve is adjustable from 25 to 75 psi. The set screw located at the top of the diaphragm adjusts the pressure, turn clockwise to increase the pressure and counter-clockwise to decrease the pressure.
4. Install the factory supplied in-line pressure and temperature gauge in the entering cold/warm water line. **NOTE:** The temperature sensing element must be in the water stream.
5. Install the combination temperature and pressure safety relief valve in the tapping provided. Note that this is required by law for safety considerations.

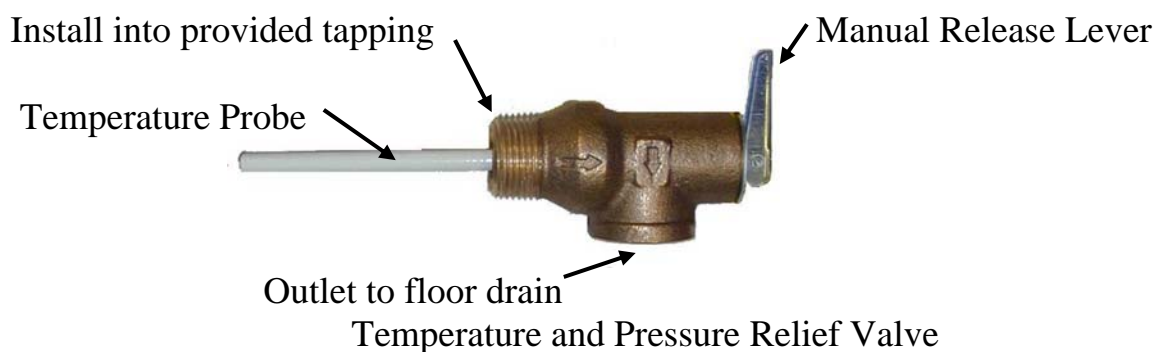

6. Install a relief valve overflow pipe to a nearby floor drain.

NOTE: Relief valve discharge piping limitations:

 - a. Termination to be plain end (no threads)
 - b. Maximum 30-feet

- c. Maximum four (4) elbows
 - d. No reduction in line size
 - e. No valve of any type to be installed between the relief valve and tank or in the drain line
 - f. Termination to be 6-inches above the drain
7. A shock absorber is recommended in the hot water outlet line to soften the water hammer caused by automatic dishwasher solenoid valves.
 8. If supplied, install the optional second dial temperature and pressure gauge in the outlet line. The temperature sensing element must be in the hot water stream and the gauge must be mounted upright.

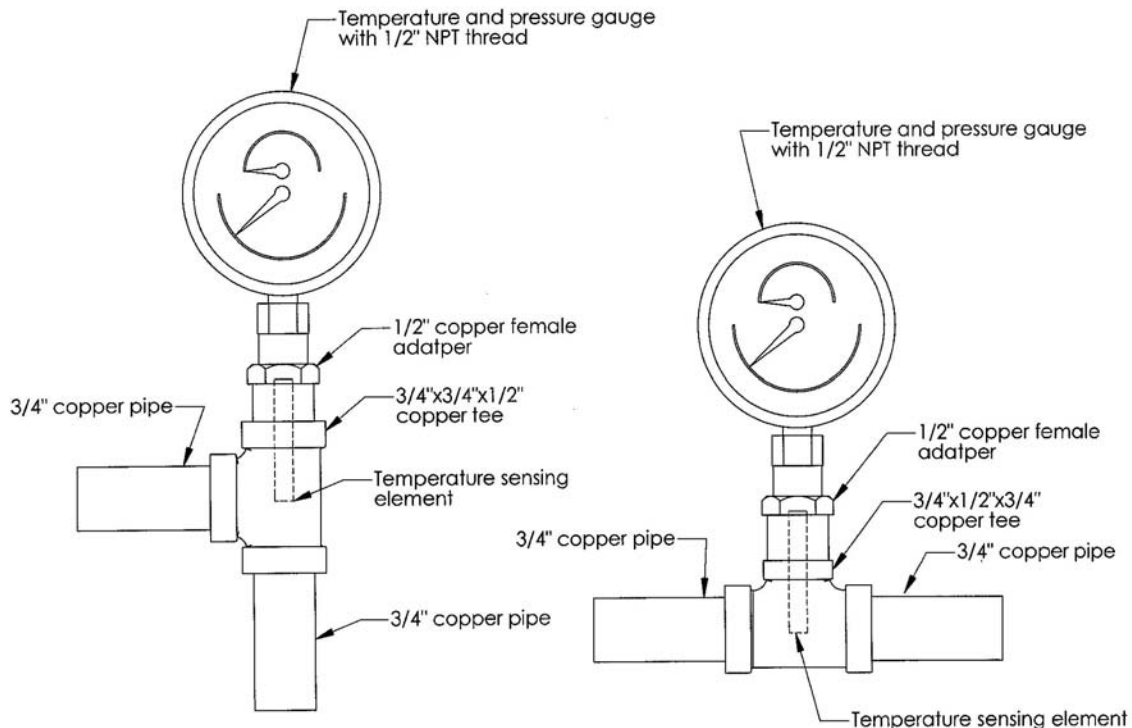

FILLING THE HEATER

1. Open the valve to the cold water inlet and allow the heater and piping system to completely fill, as indicated by a steady flow of water through the dishwasher rinse nozzles.

NOTE: Flush the tank at full flow for 10 minutes prior to putting into service.

ELECTRICAL INSTALLATION

1. Enter the base through the factory cut KO's with properly sized feeder leads, See Wiring Chart. Single-phase installations require two (2) leads. All Hubbell 3-phase heaters are intended for use with a 3-wire delta system plus ground. No neutral is required. For a 4-wire plus ground system, install 3 legs of power plus the ground and terminate the neutral leg.
2. Install these power leads into the box lugs on the power distribution block or magnetic contactor, as required.
3. Connect incoming ground wire to ground lug supplied.
4. Check for proper grounding. Check for AC millivolts (mV) between the ground connection at the booster and the inlet piping past the dielectric union (on the building side, not the booster side). There should be zero potential/millivolts (mV). If not zero, then the piping should be re-grounded.
5. All other electrical connections are made at the factory; therefore, no other electrical connections are necessary.
6. Check all connections, including factory connections, for tightness.

OPTIONAL XB1 LOW TEMPERATURE INTERLOCK

1. If desired, the XB1 can be used as an alarm relay or a temperature interlock at a setpoint other than the water temperature setpoint on the booster heater.
2. If the XB1 is not factory installed, mount the XB1 to the control panel, plug the P65 probe into the XB1, and plug the XB1 into the T1000 control board.

- To set the XB1 setpoint, turn the potentiometer clockwise for a higher setpoint and counter-clockwise for a lower setpoint. The range is adjustable between 150°F and 180°F.
- Make connections as required to the relay terminal block. When the temperature drops below the XB1 setpoint the relay is open between Normally Open (NO) and Common (C) and the LED will flash green. When the temperature is above the XB1 setpoint the relay is closed between NO and C and the LED will be solid green. Use NO and C for low temperature interlock or high temperature alarm. Use Normally Closed (NC) and C for low temperature alarm. A red LED indicates an error.

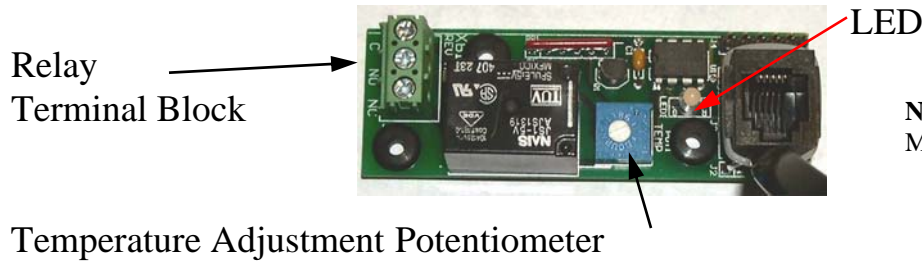

Note: Rating (resistive):
 Max.: 5A @ 120VAC
 5A @ 24VDC

FOR REMOTE ON/OFF CONTROL

To remotely control the On / Off operation of the heater, it is recommended that a DPST switch or relay (by others) be used to break both power legs (white and black wires) connected to the top two terminals of the J5 connector on the control board. See diagram at right.

Use a NC (Normally Closed) relay to turn the booster ON when energizing the relay coil or to turn the booster OFF when de-energizing the relay coil.

Use a NO (Normally Open) relay to turn the booster OFF when energizing the relay coil or to turn the booster ON when de-energizing the relay coil.

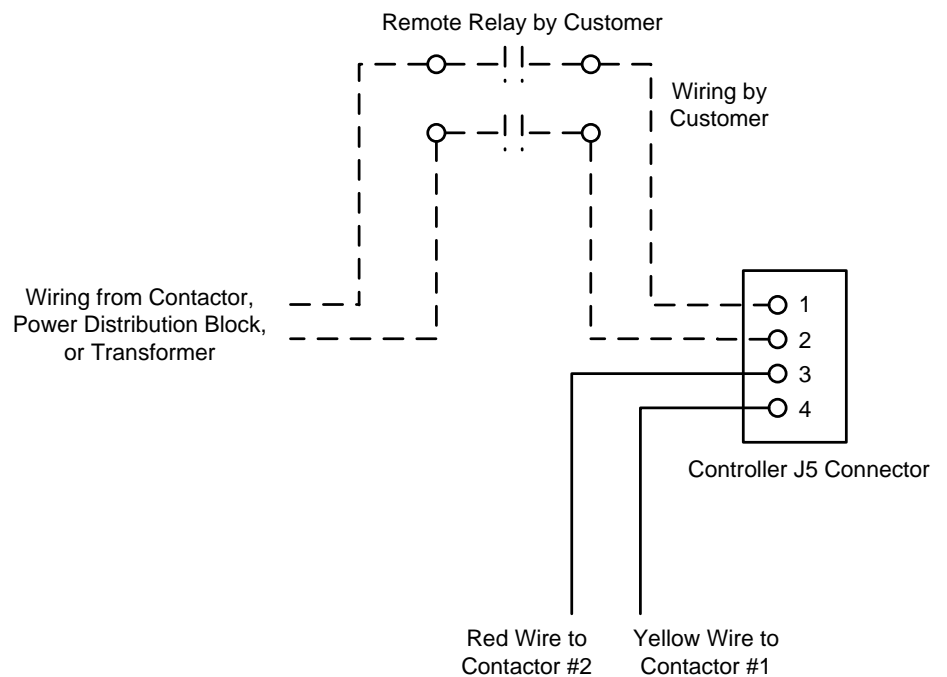

OPTIONAL REMOTE ALARM CONTACTS

- If desired, the control board can be wired to a remote alarm to indicate a reset fault condition. These fault conditions include over-temperature, no probe, and low water (when the configuration is set to manual reset).
- This alarm can be wired to the J4 connector on the control board as shown below. To facilitate this installation, an optional adapter, Hubbell P/N PLUG ADAPTER J4, can be purchased to provide wire connections.

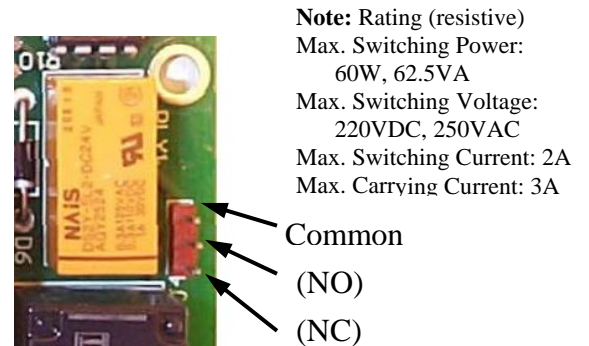
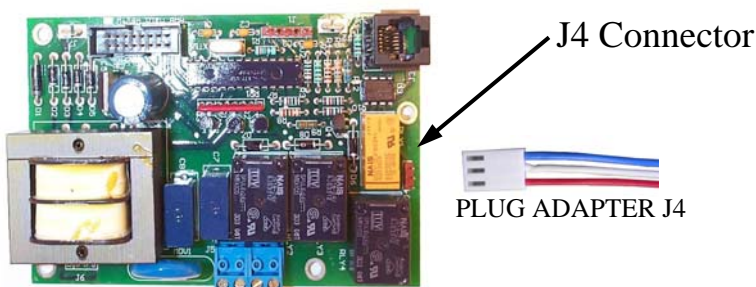

Note: Rating (resistive)
 Max. Switching Power: 60W, 62.5VA
 Max. Switching Voltage: 220VDC, 250VAC
 Max. Switching Current: 2A
 Max. Carrying Current: 3A

OPTIONAL FIELD CONVERSION FROM SINGLE TO THREE PHASE OR THREE TO SINGLE PHASE (J6 and J16 models in 6, 7, and 9 kW and 208 and 240 volts and J411 models only)

1. For J6 and J16 models:
 - a. Find the appropriate diagram for the unit to be converted in the following chart titled “Wiring Chart”.
 - b. Re-wire the unit according to the diagram.

NOTE: The wire to be used for internal wiring must conform to SEW-2 or PTFE (200°C) and must match the wire size currently in use. Contact the factory for assistance, if required.
 - c. Contact the factory for correct labels. The factory will need the serial number for proper identification.
2. For J411 models:
 - a. Re-wire the unit to desired configuration as indicated below.

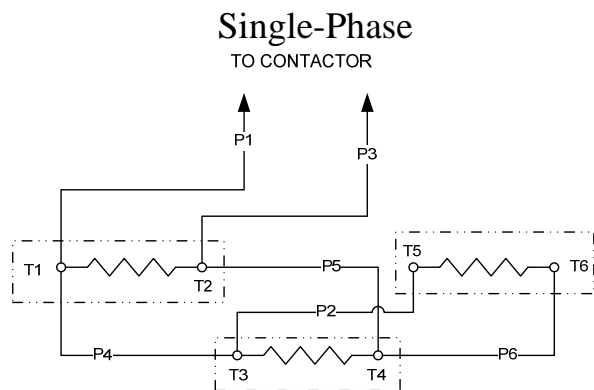

SINGLE PHASE

WIRING DIAGRAM SHOWN IS FOR MODEL J411RS (SINGLE PHASE). TO FIELD CONVERT TO 3-PHASE, REMOVE WIRE P2 AND RECONNECT IT BETWEEN TERMINALS T6 AND THE CONTACTOR AND REMOVE WIRE P5 AND RECONNECT IT BETWEEN TERMINALS T2 AND T5.

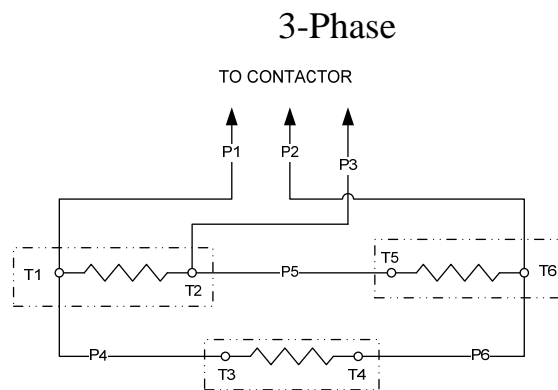

3-PHASE

WIRING DIAGRAM SHOWN IS FOR MODEL J411R (3-PHASE). TO FIELD CONVERT TO SINGLE PHASE, REMOVE WIRE P2 AND RECONNECT IT BETWEEN TERMINALS T3 AND T5 AND REMOVE WIRE P5 AND RECONNECT IT BETWEEN TERMINALS T2 AND T4.

OPTIONAL 24-VOLT HEATER INTERLOCK ADAPTER

1. If desired, the heater can be wired to operate only when supplied with a 24-volt signal through the heater interlock adapter. When no 24-volt signal is supplied through the heater interlock adapter the heater is interlocked and will not energize. When interlocked the display will show “HLd”. The heater will resume normal operation when a 24-volt signal is re-applied through the heater interlock adapter.
2. To utilize this feature, plug the 24-volt heater interlock adapter into terminal J1 of the control board and verify that the configuration is set to “Hon”, see the controller operation section for further detail. The signal can be either AC or DC. However, if a DC signal is utilized and the interlock feature does not operate, switch the two 24-volt supply wires at the heater interlock adapter.

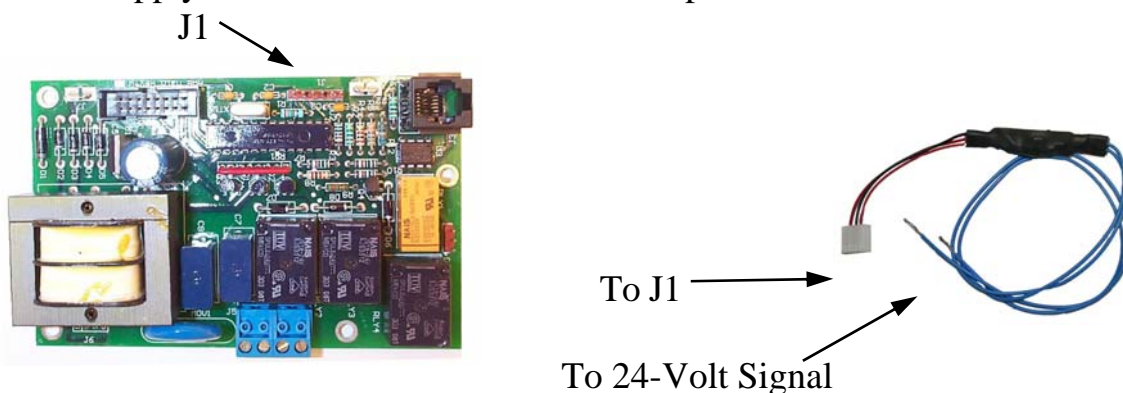

FINAL CHECKS

1. Check all connections for tightness.
2. Ensure that all the above steps are completed.
3. Remove the protective outer plastic covering from the sheet metal shell.
4. After the water is heated for the first time, monitor the water temperature as described in Section III, Annual Inspection.

J6 and J16 Wiring Chart

kW	Volt	Ph	Unit Amp Draw	Branch Amp Draw	Phase-Phase Resistance (Ohms)	Min. Feed Breaker or Fuse Size	Internal Power Wire Size	Element Jumper Wire Size	Copper Power Feed Wire Size	Conduit Size	Diagram
1	120	1	8.3	8.3	14.4	15	12	N/A	14	½"	1(NT)
1.5	120	1	12.5	12.5	9.6	20	12	N/A	14	½"	1(NT)
2	120	1	16.7	16.7	7.2	25	12	N/A	12	½"	1(NT)
3	120	1	25.0	25.0	4.8	35	12	12	10	½"	1(NT)
4	208	1	19.2	19.2	10.8	25	12	N/A	10	½"	1(NT)
	240	1	16.7	16.7	14.4	25	12	N/A	12	½"	1(NT)
	380	1	10.7	10.7	36.1	15	12	N/A	12	½"	1(WT)
	480	1	8.3	8.3	57.6	15	12	N/A	14	½"	1(WT)
5	208	1	24.0	24.0	8.7	30	12	N/A	10	½"	1(NT)
	240	1	20.8	20.8	11.5	30	12	N/A	10	½"	1(NT)
	380	1	13.2	13.2	28.9	20	12	N/A	12	½"	1(WT)
	480	1	10.4	10.4	46.1	15	12	N/A	14	½"	1(WT)
6	208	1	28.8	28.8	7.2	40	12	12	8	½"	4
	208	3	16.7	16.7	14.4	25	12	12	10	½"	10(NT)
	240	1	25.0	25.0	9.6	35	12	12	8	½"	4
	240	3	14.4	14.4	19.2	20	12	12	12	½"	10(NT)
	380	3	8.6	8.6	48.1	15	12	12	14	½"	10(WT)
	480	3	7.2	7.2	76.8	10	12	12	14	½"	10(WT)
	600	3	6.0	6.0	114.8	10	12	12	14	½"	14
7	208	1	32.5	32.5	6.4	45	12	12	8	½"	4
	208	3	18.7	18.7	12.4	25	12	12	10	½"	10(NT)
	240	1	30.5	30.5	8.2	40	12	12	8	½"	4
	240	3	17.6	17.6	16.5	25	12	12	10	½"	10(NT)
	380	3	10.0	10.0	41.3	15	12	12	12	½"	10(WT)
	480	3	8.4	8.4	65.8	15	12	12	14	½"	10(WT)
	600	3	6.8	6.8	102.0	10	12	12	14	½"	14
9	208	1	43.3	43.3	4.8	55	10	12	6	¾"	4
	208	3	25.0	25.0	9.6	35	10	12	8	½"	10(NT)
	240	1	37.5	37.5	6.4	50	10	12	8	½"	4
	240	3	21.7	21.7	12.8	30	10	12	10	½"	10(NT)
	380	3	14.3	14.3	32.1	20	12	12	12	½"	10(WT)
	480	3	10.8	10.8	51.2	15	12	12	14	½"	10(WT)
	600	3	9.1	9.1	76.5	15	12	12	14	½"	14
10.5	208	1	48.8	48.8	4.3	65	8	10	6	¾"	4
	208	3	29.1	29.1	8.2	40	12	12	8	½"	10(NT)
	240	1	43.8	43.8	5.5	55	10	12	6	¾"	4
	240	3	25.3	25.3	11.0	35	12	12	8	½"	10(NT)
	380	3	17.1	17.1	27.5	25	12	12	10	½"	10(WT)
	480	3	12.6	12.6	43.9	20	12	12	12	½"	10(WT)
	600	3	10.2	10.2	68.1	15	12	12	14	½"	14
12	208	1	57.7	57.7	3.6	75	8	10	4	1"	4
	208	3	33.3	33.3	7.2	45	12	12	8	½"	10(NT)
	240	1	50.0	50.0	4.8	65	8	10	6	¾"	4
	240	3	28.9	28.9	9.6	40	12	12	8	½"	10(NT)
	380	3	18.6	18.6	24.1	25	12	12	10	½"	10(WT)
	480	3	14.4	14.4	38.4	20	12	12	12	½"	10(WT)
	600	3	11.3	11.3	61.2	15	12	12	14	½"	14
13.5	208	1	64.9	64.9	3.2	85	8	10	4	1"	4
	208	3	37.5	37.5	6.4	50	10	12	8	½"	10(NT)
	240	1	56.3	56.3	4.3	75	8	10	4	1"	4
	240	3	32.5	32.5	8.5	45	12	12	8	½"	10(NT)
	380	3	21.4	21.4	21.4	30	12	12	10	½"	10(WT)
	480	3	16.2	16.2	34.1	25	12	12	12	½"	10(WT)
	600	3	13.6	13.6	51.0	20	12	12	12	½"	14

J6 and J16 Wiring Chart (cont.)

kW	Volt	Ph	Unit Amp Draw	Branch Amp Draw	Phase-Phase Resistance (Ohms)	Min. Feed Breaker or Fuse Size	Internal Power Wire Size	Element Jumper Wire Size	Copper Power Feed Wire Size	Conduit Size	Diagram
15	208	1	72.1	72.1	2.9	95	6	8	3	1"	4 (DB)
	208	3	41.6	41.6	5.8	55	10	12	6	¾"	10(NT)
	240	1	62.5	62.5	3.8	80	8	10	4	1"	4
	240	3	36.1	36.1	7.7	50	10	12	8	½"	10(NT)
	380	3	22.9	22.9	19.3	30	12	12	8	½"	10(WT)
	480	3	18.0	18.0	30.7	25	12	12	10	½"	10(WT)
	600	3	14.7	14.7	47.1	20	12	12	12	½"	14
18	208	1	86.5	86.5	2.4	110	6	8	2	1"	4 (DB)
	208	3	50.0	50.0	4.8	65	8	10	6	¾"	10(NT)
	240	1	75.0	75.0	3.2	95	6	8	3	1"	4 (DB)
	240	3	43.3	43.3	6.4	55	10	12	6	¾"	10(NT)
	380	3	27.9	27.9	16.0	35	12	12	8	½"	10(WT)
	480	3	21.7	21.7	25.6	30	12	12	10	½"	10(WT)
	600	3	18.1	18.1	38.3	25	12	12	12	½"	14
24	208	1	115.4	38.5	1.8	145	10	12	1/0	1¼"	3A
	208	3	66.6	66.6	3.6	85	8	10	4	1"	13(NT)
	240	1	100.0	33.3	2.4	130	12	12	1	1¼"	3A
	240	3	57.7	57.7	4.8	75	8	10	4	1"	13(NT)
	380	3	37.1	37.1	12.0	50	10	12	6	¾"	13(WT)
	480	3	28.9	28.9	19.2	40	12	12	8	½"	13(WT)
	600	3	22.6	22.6	30.6	30	12	12	10	½"	15
27	208	1	130.0	43.3	1.6	165	10	12	2/0	1½"	6A
	208	3	74.9	37.5	3.2	95	10	12	3	1"	12(NCB)
	240	1	112.5	37.5	2.1	145	10	12	1/0	1¼"	3A
	240	3	65.0	65.0	4.3	85	8	10	4	1"	13(NT)
	380	3	42.9	42.9	10.7	55	10	12	6	¾"	13(WT)
	480	3	32.5	32.5	17.1	45	12	12	8	½"	13(WT)
	600	3	27.2	27.2	25.5	35	12	12	8	½"	15
30	208	1	144.2	48.1	1.4	185	8	10	3/0	1½"	6A
	208	3	83.3	41.6	2.9	105	10	12	2	1"	12(NCB)
	240	1	125.0	41.7	1.9	160	10	12	2/0	1½"	6A
	240	3	72.2	36.1	3.8	95	10	12	3	1"	12(NCB)
	380	3	45.7	45.7	9.6	60	10	12	4	1"	13(WT)
	480	3	36.1	36.1	15.4	50	10	12	8	½"	13(WT)
	600	3	29.4	29.4	23.6	40	12	12	8	½"	15
36	208	1	173.1	57.7	1.2	220	8	10	4/0	2"	6A
	208	3	99.9	50.0	2.4	125	8	10	1	1¼"	12(NCB)
	240	1	150.0	50.0	1.6	190	8	10	3/0	1½"	6A
	240	3	86.6	43.3	3.2	110	10	12	2	1"	12(NCB)
	380	3	55.7	55.7	8.0	70	8	10	3	1"	13(WT)
	480	3	43.3	43.3	12.8	55	10	12	6	¾"	13(WT)
	600	3	36.2	36.2	19.1	50	10	12	8	½"	15
39	208	1	187.5	62.5	1.1	235	8	10	250	2"	6A
	208	3	108.3	54.1	2.2	140	8	10	1/0	1¼"	12(NCB)
	240	1	162.5	54.2	1.5	205	8	10	4/0	1½"	6A
	240	3	93.8	46.9	3.0	120	10	12	1	1"	12(NCB)
	380	3	60.8	60.8	7.4	80	8	10	3	1"	13(WT)
	480	3	46.9	46.9	11.8	60	8	10	6	¾"	13(WT)
	600	3	36.2	36.2	19.1	50	10	12	8	¾"	15

J6 and J16 Wiring Chart (cont.)

kW	Volt	Ph	Unit Amp Draw	Branch Amp Draw	Phase-Phase Resistance (Ohms)	Min. Feed Breaker or Fuse Size	Internal Power Wire Size	Element Jumper Wire Size	Copper Power Feed Wire Size	Conduit Size	Diagram
40.5	208	1	195.0	65.0	1.1	245	8	10	250	2"	6A
	208	3	112.6	56.3	2.1	145	8	10	1/0	1¼"	12(NCB)
	240	1	168.8	56.3	1.4	215	8	10	250	1½"	6A
	240	3	97.4	48.7	2.8	125	10	12	1	1"	12(NCB)
	380	3	60.8	60.8	7.1	80	8	10	3	1"	13(WT)
	480	3	48.7	48.7	11.4	65	8	10	4	¾"	13(WT)
	600	3	36.2	36.2	19.1	50	10	12	8	¾"	15
45	208	3	119.1	59.5	1.9	150	8	10	2/0	1¼"	12(NCB)
	240	1	187.5	62.5	1.3	235	8	10	250	2"	6A
	240	3	108.3	54.1	2.6	140	8	10	1/0	1¼"	12(NCB)
	380	3	68.6	34.3	6.4	90	12	12	2	1"	12(WT)
	480	3	54.1	54.1	10.2	70	8	10	4	¾"	13(WT)
	600	3	42.2	42.2	16.4	55	10	12	6	¾"	15
54	208	3	149.9	74.9	1.6	190	6	8	3/0	1½"	12
	240	3	129.9	65.0	2.1	165	8	10	2/0	1½"	12
	380	3	80.0	40.0	5.3	100	10	12	1	1"	12(WT)
	480	3	65.0	65.0	8.5	85	8	10	4	1"	13(WT)
	600	3	54.3	54.3	12.8	70	8	10	4	1"	15
58.5	208	3	159.9	79.9	1.5	200	6	8	4/0	1½"	12
	240	3	140.7	70.4	2.0	180	6	8	2/0	1½"	12
	380	3	91.4	45.7	4.9	115	10	12	1	1"	12(WT)
	480	3	70.4	35.2	7.9	90	12	12	3	1"	12(WT)
	600	3	54.3	54.3	12.3	70	8	10	4	1"	15
64	208	3	178.6	59.5	1.4	225	8	10	4/0	1½"	17
66	600	3	63.4	63.4	10.9	80	8	10	4	¾"	18
68	240	3	162.4	54.1	1.7	205	8	10	4/0	1½"	17
	380	3	102.8	34.3	4.2	130	12	12	1/0	1¼"	16(WT)
	480	3	81.2	27.1	6.8	105	12	12	2	1"	16(WT)
79	380	3	120.0	40.0	3.7	150	10	12	2/0	1¼"	16(WT)
81	208	3	224.8	74.9	1.1	285	6	8	300	2"	17
	240	3	194.9	65.0	1.4	245	8	10	250	2"	17
	480	3	105.5	35.2	5.7	135	12	12	1	1"	16(WT)
85	600	3	81.5	81.5	8.5	105	6	8	2	1"	18
86	208	3	239.8	79.9	1.0	300	6	8	350	2"	17
88	240	3	211.1	70.4	1.3	265	6	8	300	2"	17
	480	3	105.5	35.2	5.2	135	12	12	1/0	1¼"	16(WT)
90	380	3	137.1	45.7	3.2	175	10	12	2/0	1½"	16(CBWT)

J6 and J16 Wiring Chart Notes:

1. Power feed wire sizing is based on using 75°C Cu THHN wire with feeder branch protection rated at 125%.
2. Internal wire sizing is based on using 200°C SEW-2 or PTFE wiring in a raceway with an ambient temperature up to 60°C.
3. For information on 277V, 415V, or 440V models reference the supplied drawing or contact the factory.
4. Normal phase-to-phase resistance tolerance is ±5%.
5. 380, 480, and 600-volt phase-to-phase resistance values are shown with the transformer disconnected.
6. For 575V models, multiply the kW rating of the 600V model by a de-rating factor of 0.92 to get the actual rating for 575V.
7. For models manufactured prior to June 24, 2005, that utilize wiring diagrams 3, 5, 6, 7(NT), 7(WT), or 11 please contact the factory for wiring diagrams.

J3 Wiring Chart

kW	Volt	Ph	Unit Amp Draw	Phase-Phase Resistance (Ohms)	Min. Feed Breaker or Fuse Size	Internal Power Wire Size	Element Jumper Wire Size	Copper Power Feed Wire Size	Conduit Size	Diagram
2.9	120	1	23.8	5.0	30	12	12	10	½"	4
5.7	120	1	47.5	2.5	60	10	12	6	¾"	4
9.9	208	1	47.6	4.4	60	10	12	6	¾"	4
	208	3	27.5	8.7	35	12	12	8	½"	10 (NT)
10.4	208	1	51.9	4.2	65	10	12	6	¾"	4
	208	3	28.8	8.3	40	12	12	8	½"	10 (NT)
11.4	240	1	47.5	5.1	60	10	12	6	¾"	4
	240	3	27.4	10.1	35	12	12	8	½"	10 (NT)
	277	1	41.2	6.7	55	10	12	6	¾"	4 (WT)
	380	3	16.8	25.3	25	12	12	12	½"	14
	415	3	15.9	30.2	20	12	12	12	½"	14
	480	3	13.7	40.4	20	12	12	14	½"	14
	600	3	11.0	63.2	15	12	12	14	½"	14

J3 Wiring Chart Notes:

1. Power feed wire sizing is based on using 75°C Cu THHN wire with feeder branch protection rated at 125%.
2. Internal wire sizing is based on using 200°C SEW-2 or PTFE wiring in a raceway with an ambient temperature up to 60°C.
3. Normal phase-to-phase resistance tolerance is ±5%.
4. 277, 380, 415, 480, and 600-volt phase-to-phase resistance values are shown with the transformer disconnected.

J4 Wiring Chart

kW	Volt	Ph	Unit Amp Draw	Phase-Phase Resistance (Ohms)	Min. Feed Breaker or Fuse Size	Internal Power Wire Size	Element Jumper Wire Size	Copper Power Feed Wire Size	Conduit Size	Diagram
11.3	208	1	54.1	3.8	70	8	8	4	1"	4
	208	3	31.2	7.7	40	8	8	8	½"	10 (NT)
12.6	220	1	57.3	3.8	75	8	8	4	1"	4
	220	3	33.1	7.7	45	8	8	8	½"	10 (NT)
13.8	230	1	59.8	3.8	75	8	8	4	1"	4
	230	3	34.5	7.7	45	8	8	8	½"	10 (NT)
15	240	1	62.5	3.8	80	8	8	4	1"	4
	240	3	36.1	7.7	50	8	8	8	½"	10 (NT)
	480	3	18.0	30.7	25	12	12	10	½"	10 (WT)
27	208	3	75.0	3.2	95	6	8	3	1"	10 (NT)
	240	3	65.0	4.3	85	8	10	4	1"	10 (NT)
	480	3	32.5	17.1	45	12	12	8	½"	10 (WT)

J4 Wiring Chart Notes:

1. Power feed wire sizing is based on using 75°C Cu THHN wire with feeder branch protection rated at 125%.
2. Internal wire sizing is based on using 200°C SEW-2 or PTFE wiring in a raceway with an ambient temperature up to 60°C.
3. Normal phase-to-phase resistance tolerance is ±5%.
4. 480-volt phase-to-phase resistance values are shown with the transformer disconnected.

Note: Wiring diagrams 3, 5, 6, 7 (NT), 7 (WT), and 11 are obsolete.

1(WT)

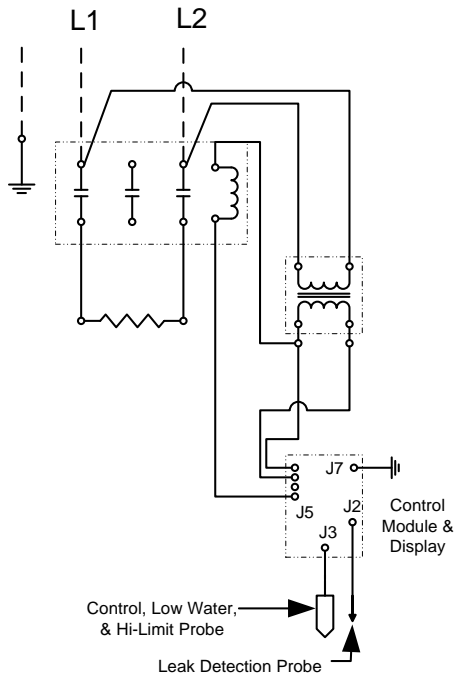

1(NT)

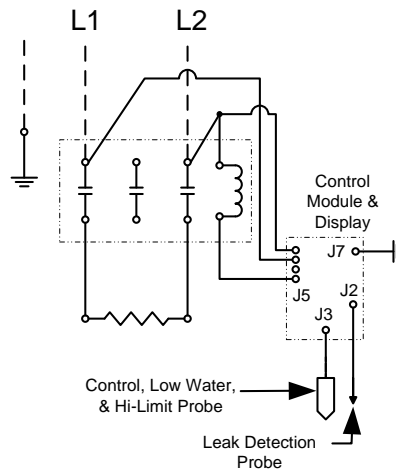

10(WT)

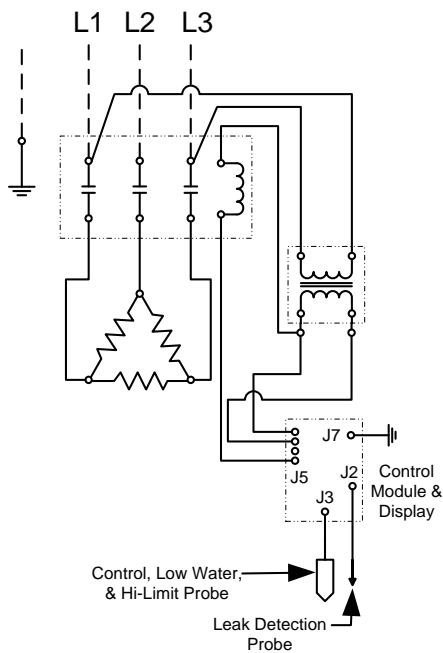

10(NT)

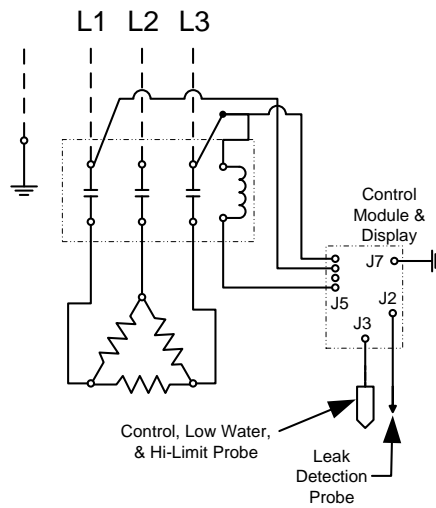

17

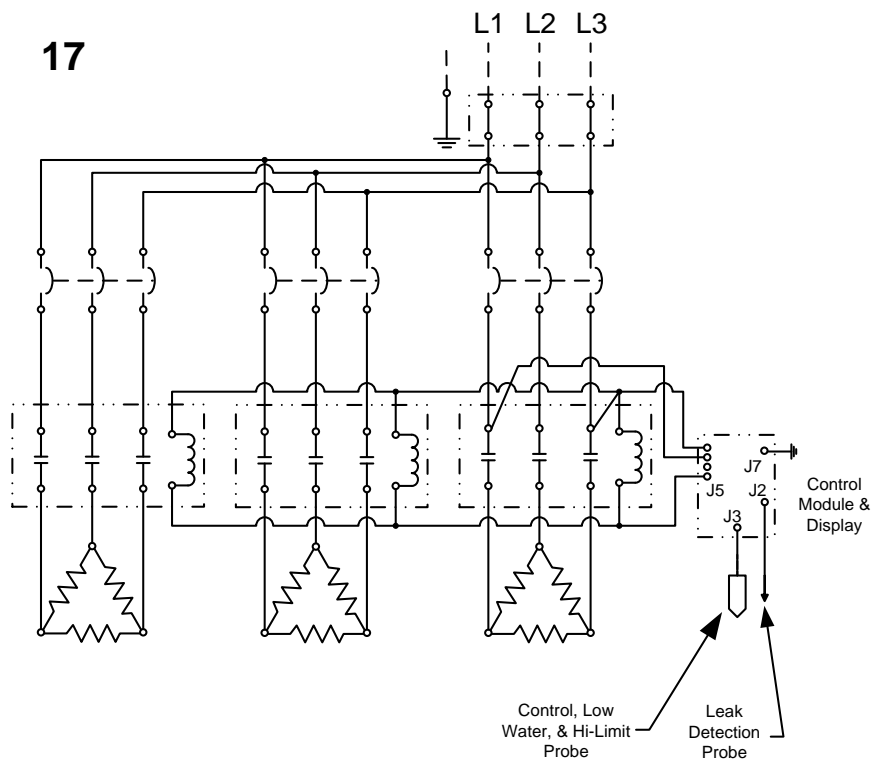

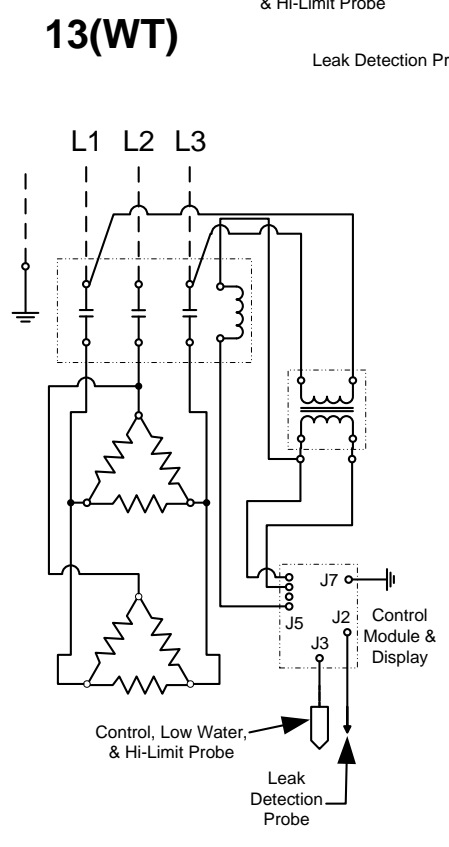
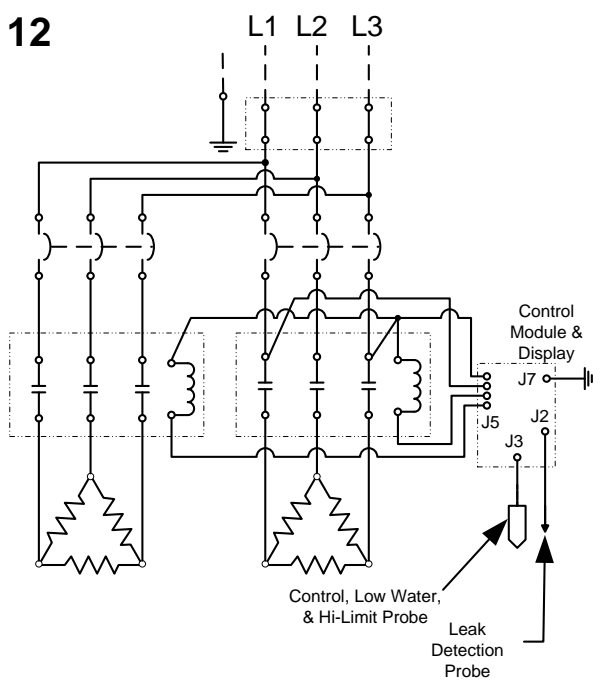
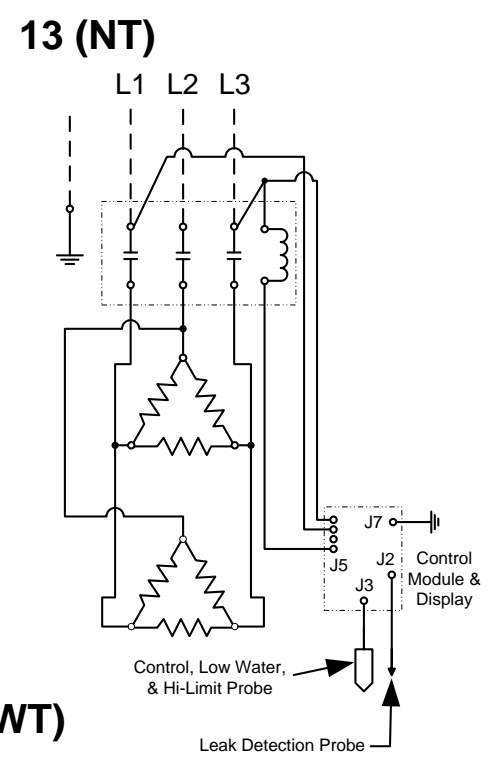
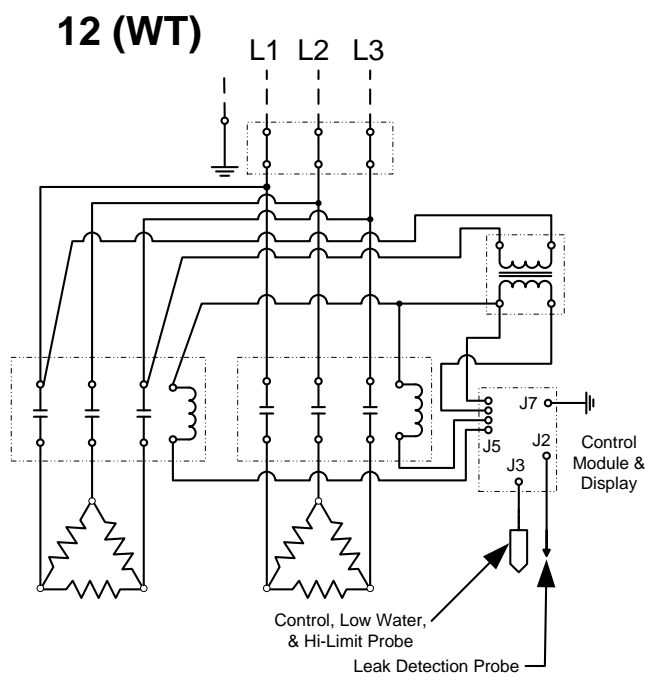
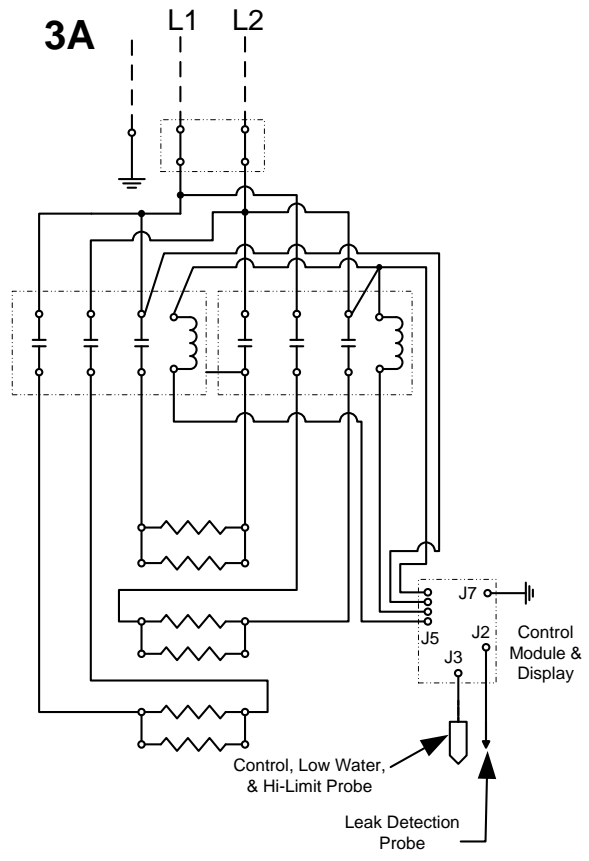
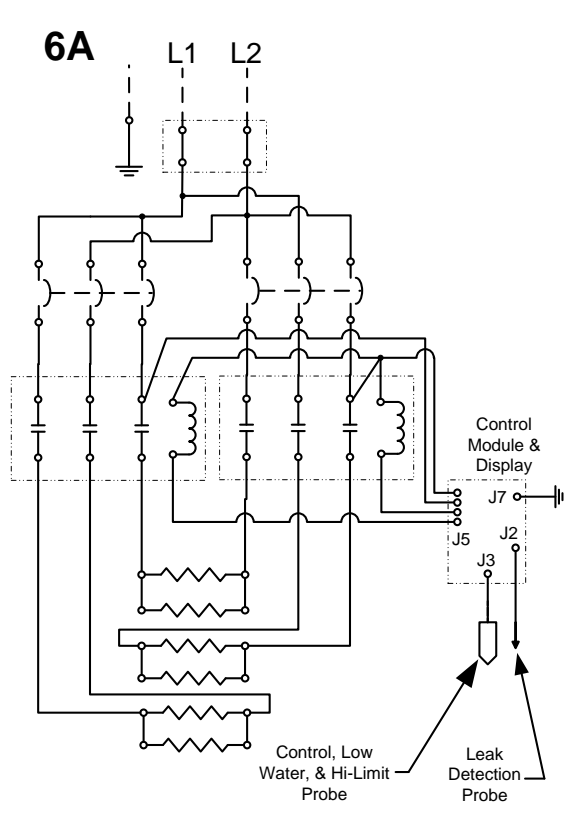

4(WT)

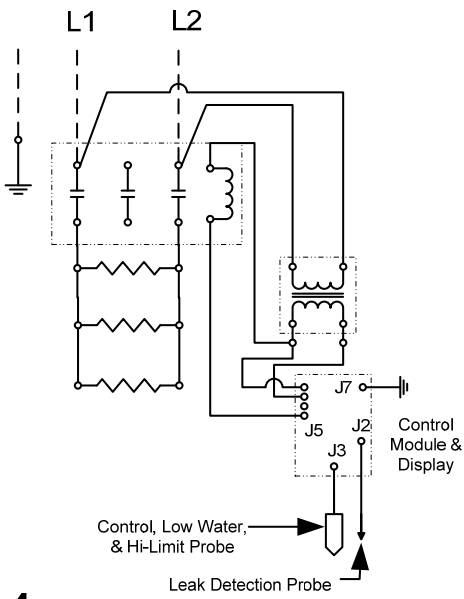

16(WT)

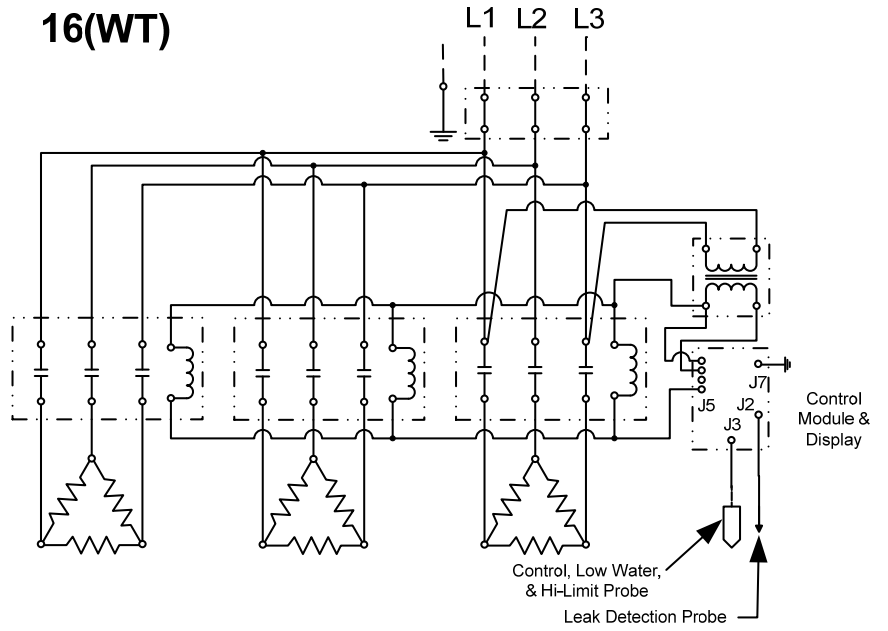

4

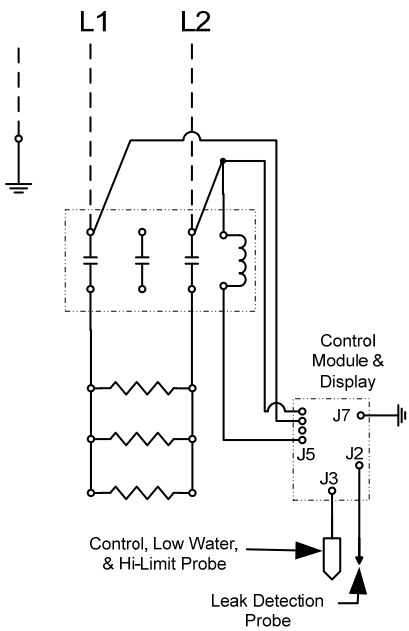

16(CBWT)

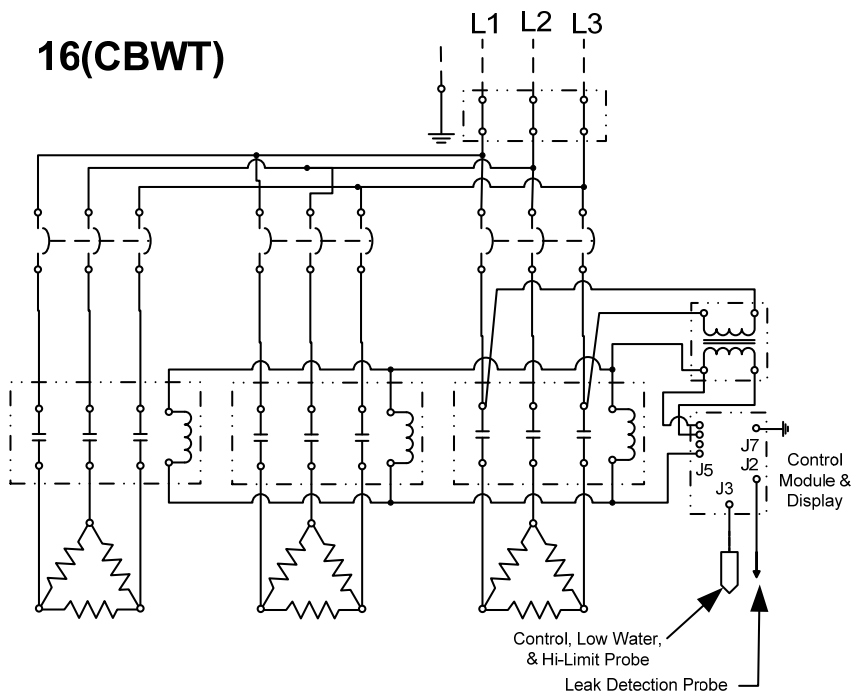

4 (DB)

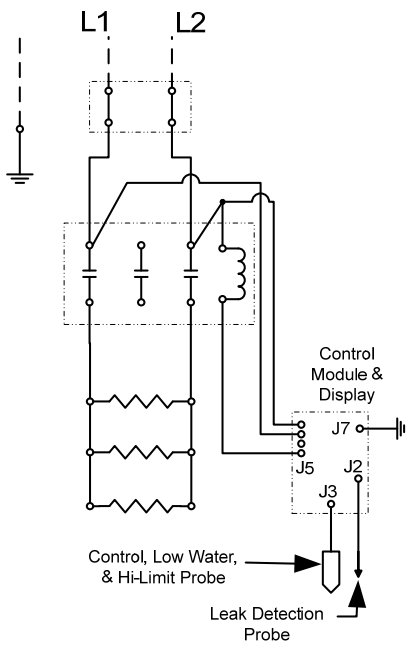

18

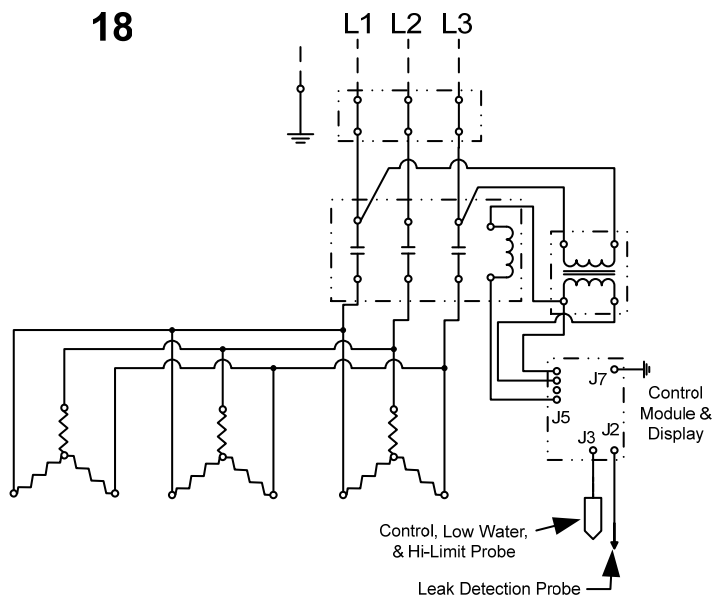

12 (NCB)

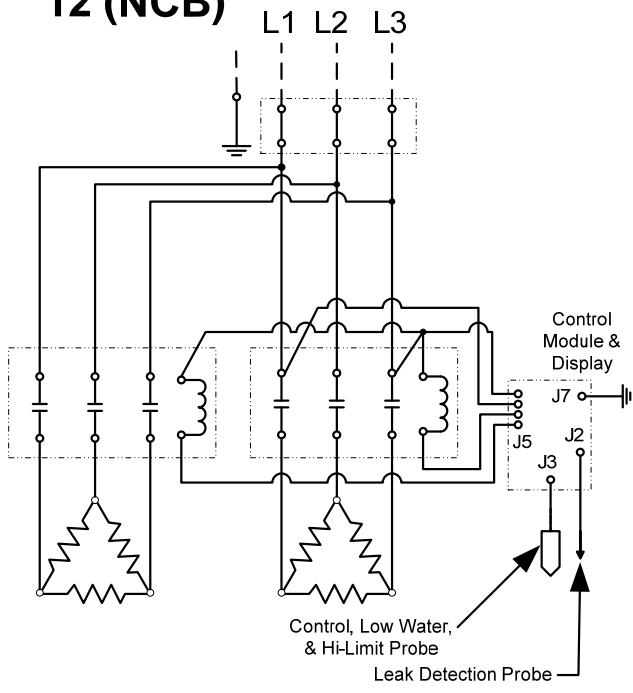

15

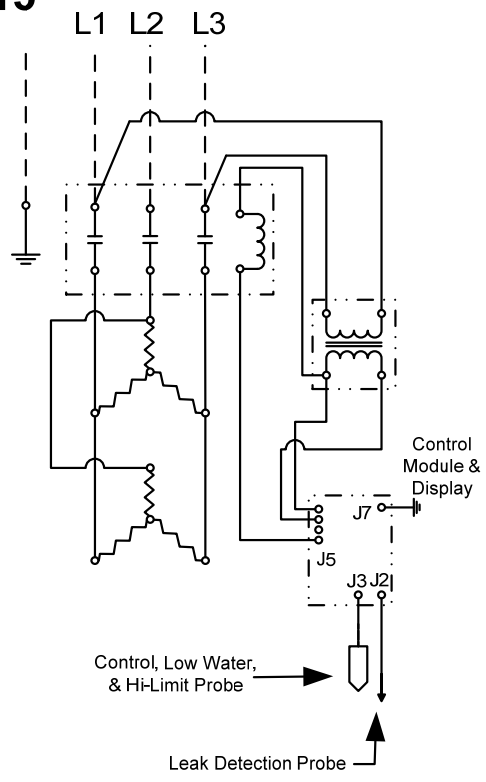

14

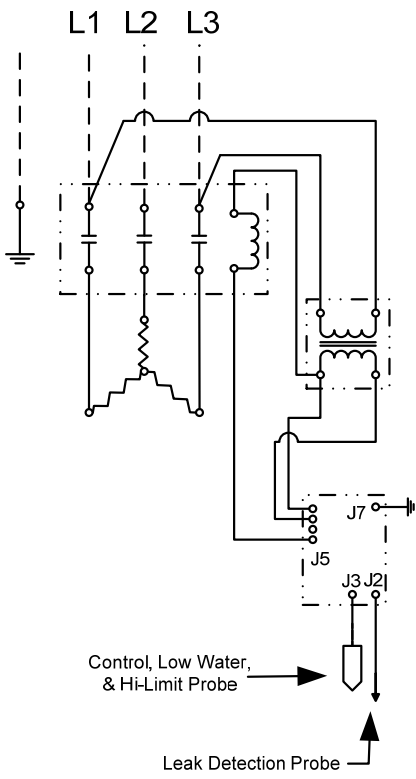

Typical J6 Plumbing Connections (Rear View)

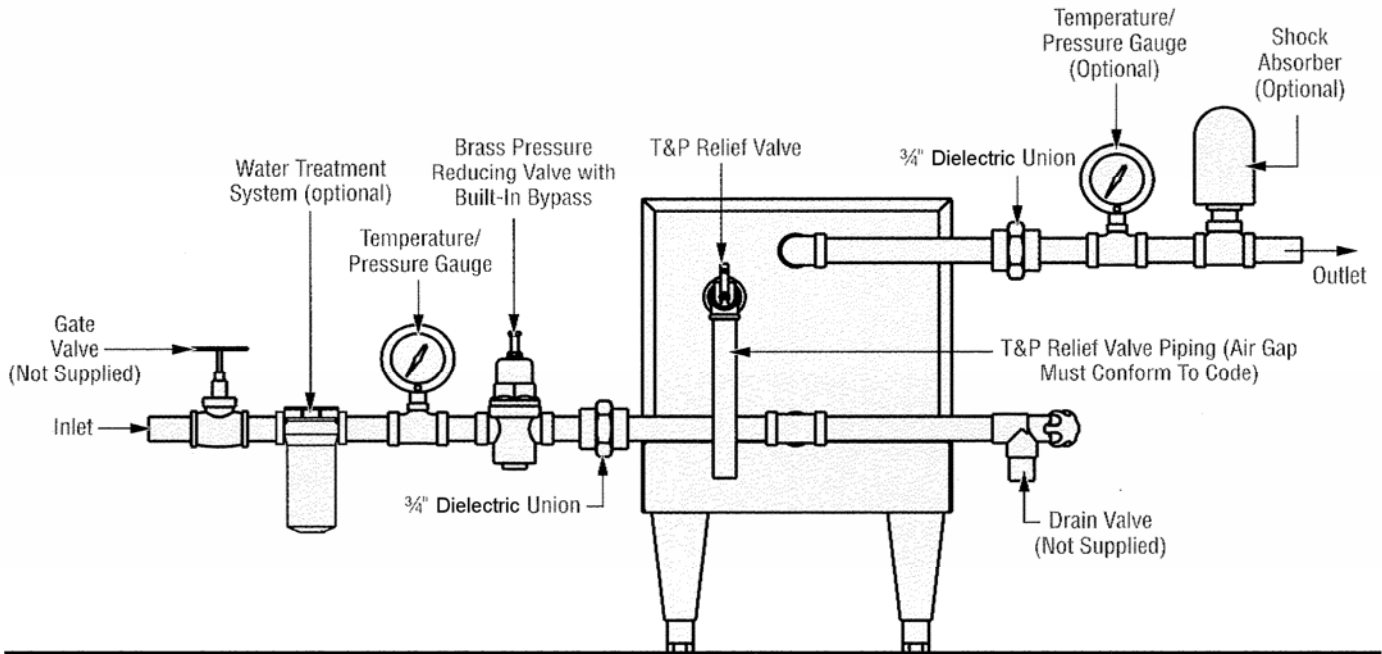

Typical J16 Plumbing Connections (Front View)

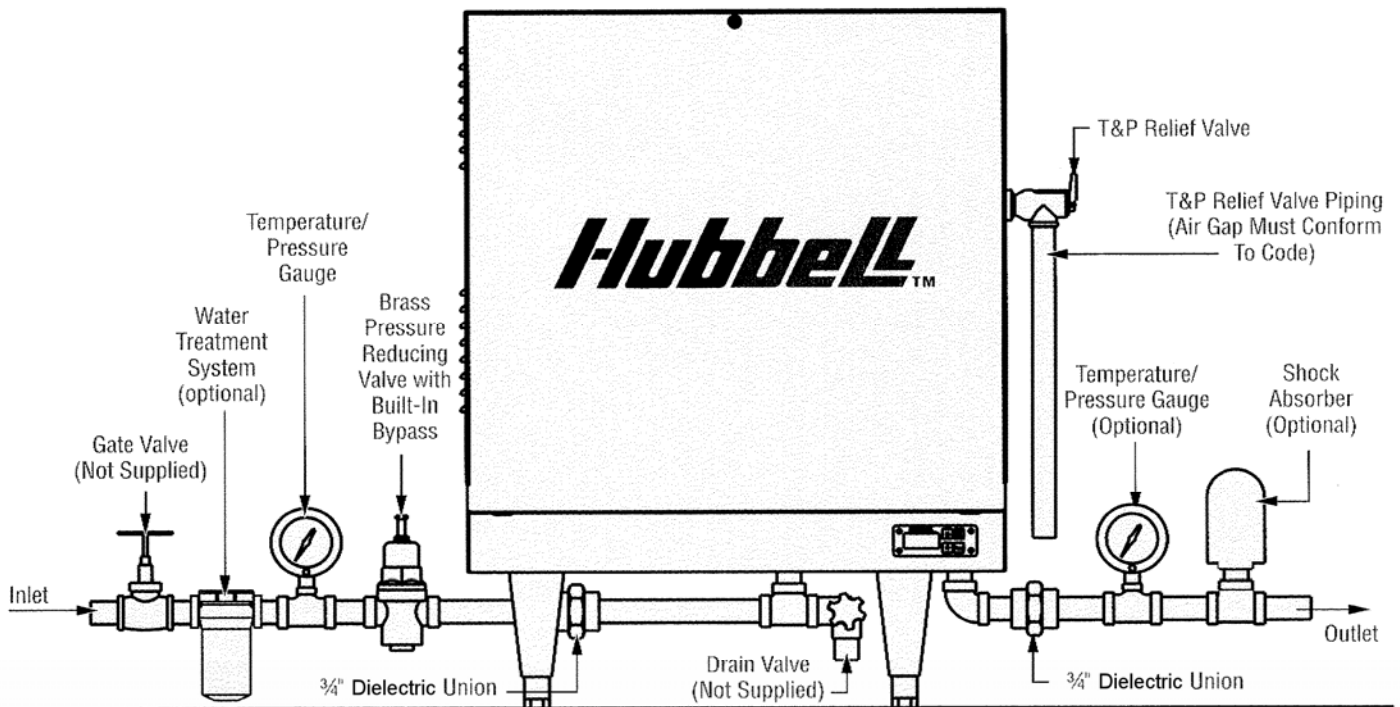

Typical J4 Plumbing Connections (Rear View, shown with optional legs)

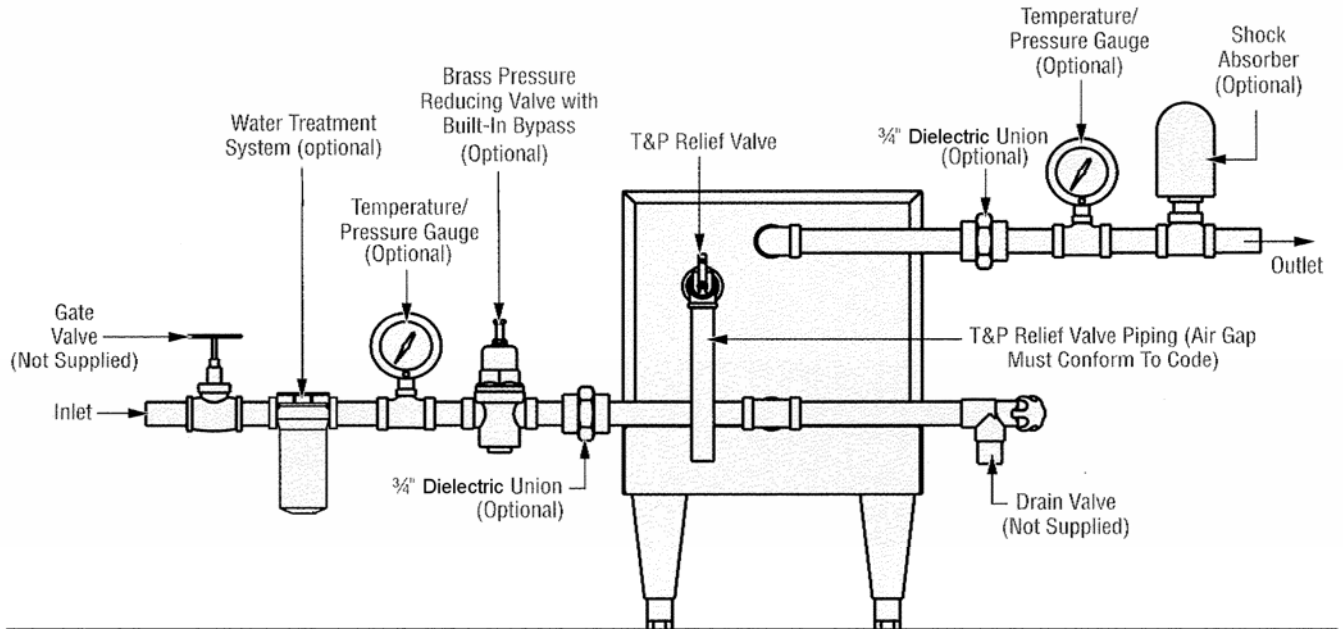

Typical J3 Plumbing Connections (Front View, shown with optional legs)

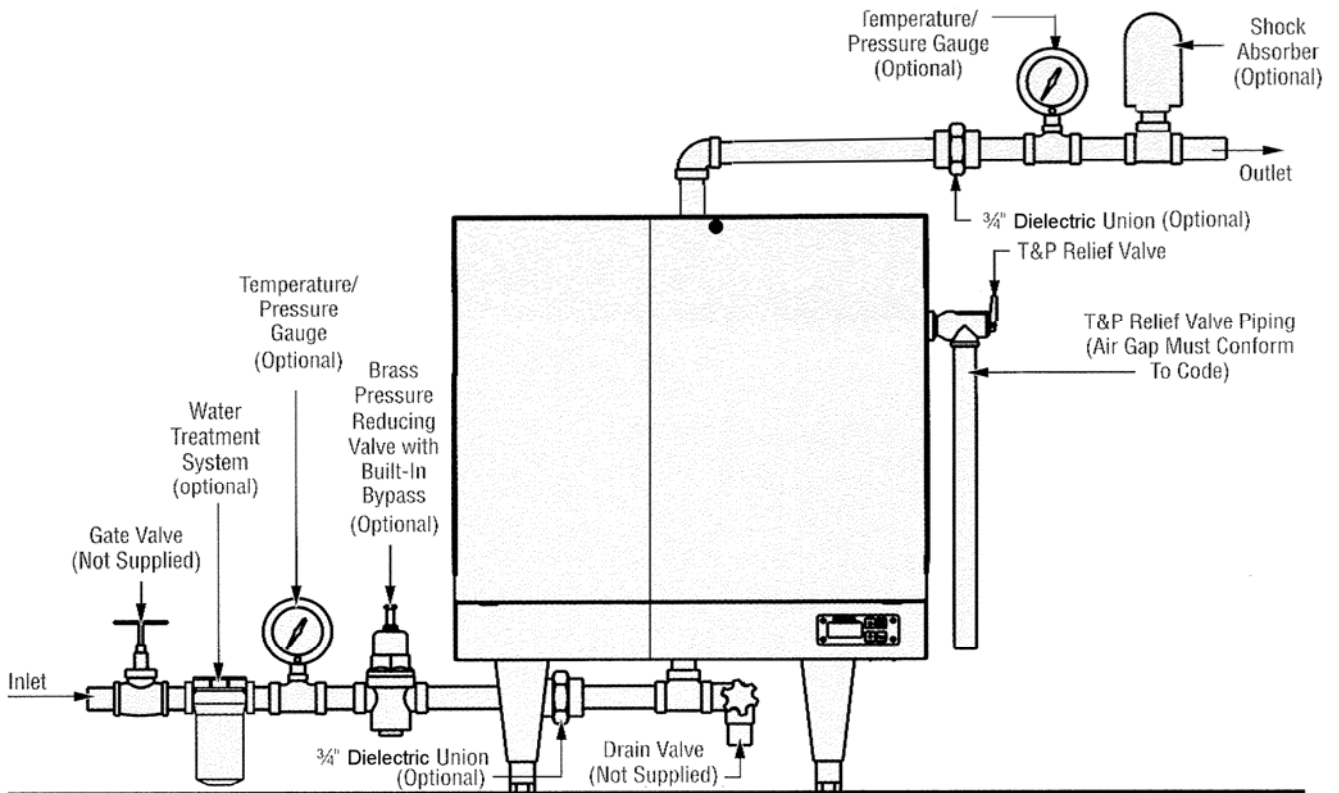

SECTION III – SCHEDULED MAINTENANCE AND OPERATION

WARNING / CAUTION

Before performing any maintenance procedure, make certain the power supply is turned OFF and cannot accidentally be turned on.

MAINTENANCE AND OPERATION

The water heater is automatic in its operation. It will maintain a full tank of water at the temperature setting of the controller. The water heater should not be turned on without first making sure that the tank is full of water and that all air has been released.

FREEZING

The tank should be fully drained in the event the electricity has been turned off and if there is danger of freezing.

CONTROLLER OPERATION

NOTE: All controller variables come preset from the factory to include a preset temperature of 185°F.

1. To turn unit on or off:
 - a. Press the ON/OFF button on the display module.
 - b. Note that the controller will resume its last mode of operation if power is disconnected.
2. To change setpoint temperature (the temperature is fully adjustable from 32° to 194°F (0°-90°C):
 - a. Press the UP and DOWN arrows simultaneously to enter setpoint change mode.
 - b. Press the UP or DOWN button to change the setpoint temperature.
 - c. Pressing and holding the UP or DOWN button will scroll through the setpoint temperature.
 - d. To leave setpoint change mode
 - i. Wait 5 seconds without pushing any buttons or press the UP and DOWN buttons simultaneously.
3. To view the number of operational hours (the number of hours when a contactor is pulled in) and software version:
 - a. Press the UP and DOWN arrows simultaneously to enter setpoint change mode.
 - b. Press the ON/OFF button.
 - c. Display will flash the software version (e.g. R14), HRS, followed by the hours in thousands of hours, followed by the hours.
 - i. Example: r14, HrS, 123, 456; indicates software version R1.4 and 123,456 hours.
 - d. To leave operational hours mode
 - i. Wait 5 seconds without pushing any buttons or press the UP and DOWN buttons simultaneously.
4. Configuration Menu. (NOTE: Configuration menu change should only be made by qualified personnel).
 - a. To enter the configuration menu, press and hold the UP, DOWN, and ON/OFF buttons simultaneously for 5 seconds.
 - b. To scroll through menu settings, press the ON/OFF button.
 - c. To make a change to a menu setting use either the UP or DOWN arrow.
 - d. Settings:
 - i. Relays – sets the number of magnetic contactors used in the heater.
 1. r##, where ## is the number of magnetic contactors (01 or 02).
 - ii. Low water detection – sets the low water detection on or off.
 1. LOn, for low water on. (Factory Default)

2. LOF, for low water off.
- iii. Low water reset – sets the low water reset for either automatic or manual
 1. LAU, for low water automatic reset. (Factory Default)
 2. LAn, for low water manual reset.
- iv. Temperature units – sets the temperature units to either degrees Fahrenheit or Celsius.
 1. DEF, for degrees Fahrenheit. (Factory Default)
 2. DEC, for degrees Celsius.
- v. Differential – sets the number of degrees below setpoint that the heater will resume heating after it has achieved setpoint.
 1. d##, where ## is the differential in degrees (1 to 20). (Factory set at 02)
- vi. Display – sets the display to either setpoint or actual temperature.
 1. dSS, for display setpoint temperature. (Factory Default)
 2. dSt, for display actual temperature.
- vii. Heater Interlock – sets the heater interlock mode to on or off. (Only available with r23 or later software).
 1. HoF, to disable the 24-volt interlock feature. (Factory Default)
 2. Hon, to enable the 24-volt interlock feature.
- e. To leave the configuration menu, wait 5 seconds without pushing any buttons or press the UP and DOWN buttons simultaneously.
5. To reset any high-limit, no probe, or low water (when in manual reset mode) fault condition, press the RESET button.
6. Display
 - a. By default the display will show the setpoint of the booster heater.
 - b. The decimal points on the display, as shown below, indicate that the controller is calling for a contactor to pull in.

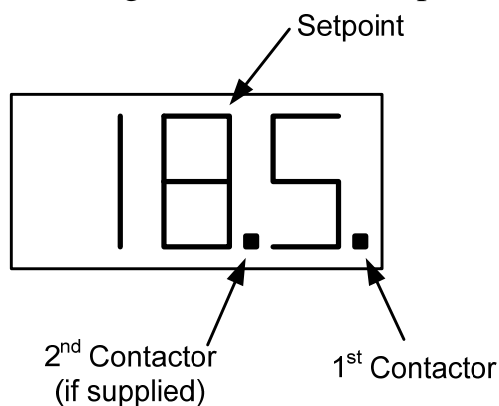

ANNUAL INSPECTION

1. Monitor water temperature
 - a. Let water heater completely heat to a designated temperature setting.
 - b. After controller satisfies (that is, when the magnetic contactor actually clicks off), draw water from as close as possible heater outlet and measure the temperature.
 - c. Compare the water temperature of outlet water to the temperature setting of the display when it satisfies. Normal variation between the two points is approximately $\pm 5^{\circ}\text{F}$.
 - d. If these two readings do not coincide within acceptable tolerances and verification has been made of the accuracy of the temperature-reading gauge, replace the control board and/or the sensor probe.
2. Lift test lever on relief valve and let water run through valve for a period of approximately 10 seconds. This will help flush away any sediment that might build up in water passageways.
3. Inspect element for leakage as follows:
 - a. Shut off power supply.

- b. Remove front cover.
- c. Visually inspect around heating element for evidence of leaks.
- d. Rub around the heating element with a rag. Check for any evidence of moisture. If moisture is present or a water drip is observed, follow procedure outlined in Section V.

CAUTION: The area around the heating element may be hot.

4. Scale and mineral build-up on heating elements is a normal condition. It is recommended that the heating element be removed for examination and if scaled, should be cleaned. In an area of known hard or poor water conditions, the elements may need to be checked more frequently. This will improve the efficiency of the heater and increase the element life.

NOTE: Failure of the elements due to scale and mineral build-up is not covered under warranty. See warranty for complete details.

- a. Shut off power supply.
 - b. Drain the tank.
 - c. Remove front cover.
 - d. Disconnect the element wiring. It is recommended that one element at a time is removed to simplify re-wiring.
 - e. Unscrew element.
 - f. Lime scale removal
 - i. Place limed ends of the heating element in a de-limer solution, designed for potable water applications, and allow lime to dissolve. Do not allow de-limer to contact heating element terminals.
 - g. Other scale removal
 - i. Silicates, sulfates, and aluminates must be removed by scraping or other mechanical means. De-limers will not dissolve these types of scale.
 - h. Flush the cleaned ends of the elements with clean water.
 - i. Re-install element with new o-ring.
 - j. Re-attach element wires.
 - k. Continue until all heating elements are cleaned.
 - l. Fill the heater following the filling instructions provided in Section II and check around the elements for leaks.
 - m. Re-apply power.
5. Check for loose electrical connections. Tighten as necessary.

SECTION IV – TROUBLESHOOTING

ERROR MESSAGES

- 1. Err, No, Prb
 - a. This message will flash when the controller does not detect that the probe is connected to the control board. To clear this error reinsert the probe connector and press RESET.
- 2. Err, too, hot, ### (where ### is the actual temperature of the water.)
 - a. This message will display if the temperature of the water exceeds the high limit temperature setpoint. To clear this error, wait until the temperature is below the operating setpoint and press RESET. Note that the unit will not reset until the indicated temperature is below 195°F. If this message continually occurs, follow the troubleshooting flow chart for continuous over-temperature condition.
- 3. Err, No, H2O
 - a. This message will display when the water level in the tank has dropped below the sensor probe. To clear this message, refill the tank. If the low water reset is set for automatic, the error will clear. If the low water reset is set for manual, when the tank is full press RESET. Check the heater and the piping for leaks.

Check for mineral buildup on the probe and clean as required. Check for continuity between the yellow wire and ground. See diagram 2 on the following page.

4. Err, H2O, LEA
 - a. This message displays if the leak detection sensor determines there is water in the base of the heater shell. To clear this message, remove the water from the leak detection sensor. Check the unit and piping for leaks.
5. CC
 - a. This message displays if the display cable is installed into the control board backwards. To clear this message, remove and correctly install the display cable.
6. 255
 - a. This message indicates that the probe is likely out of calibration. To clear this message, it is recommended that the probe be removed and replaced.
7. HLd
 - a. This message indicates that the 24-volt interlock feature is enabled, there is no 24-volt signal present, and the heater is in standby mode. If it is not the intention to operate the heater with the 24-volt interlock feature, this feature should be disabled as shown in the controller operation section. (Only available with r23 or later software).

CONTACTOR CARE

1. A chattering or humming from the contactor is due to dust or debris on the contact points that prevents the contactor from making proper contact. The debris can be removed by utilizing a can of antistatic cleaning and dusting spray (pressurized air) and spraying through the side of the contactor to remove the debris.

DISPLAY BUTTONS

1. If the display randomly changes or does not respond when the buttons are pressed, loosen the four (4) screws holding the display to the base, reseal the display in the center of the opening, and re-tighten the screws.

MISCELLANEOUS

2. If the display flashes when the unit is first turned on or turned on after maintenance, check that the J5 terminal on the controller is engaging all four pins on the board.
3. Note that before replacing the control board, display, or probe, it is recommended that the power supply to the booster heater be turned off at the main circuit breaker disconnect to the booster heater to reset and clear the electronic controller.

CAUTION: Do not use plumber's tape/Teflon tape/pipe dope when installing the probe. Tape will prevent the low water detection system from operating properly and will cause false low water errors. Lubricate O-ring prior to installation.

GENERAL TROUBLESHOOTING

Symptom	Probable Cause	Corrective Action
Water reaches setpoint temperature but does not last through the entire dishwasher cycle.	Low incoming water temperature.	Incoming water temperature must be adequate for the booster size. Increase the incoming water temperature.
	Incoming water temperature is dropping.	Primary water supply is not adequate to continually provide correct temperature in sufficient quantities. Increase the supply of primary warm water.
	Water pressure is too high.	Higher water pressure uses an excessive supply of hot water. Verify a pressure reducing valve is installed and adjust the water pressure to 20 psi.
	Booster heater may be undersized.	The booster heater must be properly sized for the incoming water and rinse requirements of the dishwasher. If required, replace with a properly sized unit.
	Incorrect voltage.	Voltage available at the booster heater must be correct for unit. Verify voltage on all phases matches nameplate on the booster heater.
	If two magnetic contactors are utilized, one is not energizing.	Verify that both magnetic contactors are operating. If not, see the 'Magnetic Contactor Troubleshooting' section.
	One or more elements are not energizing.	Verify that each element is drawing the correct amperage. Replace elements as required.
Water at the dishwasher is not the proper temperature.	Gauge(s) not reading correctly.	Check the temperature of the water with a thermometer to verify the gauges are working properly. Replace gauges, if required.
	Temperature setpoint too low.	Adjust the temperature setpoint.
	Booster heater piping to the dishwasher is not insulated.	If there is more than 5 linear feet of piping between the booster heater and the dishwasher the piping should be wrapped in insulation or a recirculating system should be installed.
	Bypass valve is open or allowing water to pass when closed.	Verify that the bypass valve between the hot and warm water lines is closed. If condition continues, replace the bypass valve.

Symptom	Probable Cause	Corrective Action
Temperature and pressure relief valve seeps	No pressure reducing valve or wrong valve installed causing excessive pressure in the unit.	The proper pressure reducing valve with high pressure bypass must be installed in the inlet water line to allow for the expansion of water.
	Pressure reducing valve bypass is blocked.	Clean the bypass or install a new valve with a built-in bypass.
	Anti-siphon valve or check valve installed in the warm water inlet line.	Remove the anti-siphon valve or the check valve to allow for the expansion of the water or install a back pressure relief valve.
Temperature and pressure relief valve opens and/or high limit temperature error occurs.	Unit is overheating due to improper P65 probe calibration.	See the 'P65 Probe Troubleshooting' section.
	Unit is overheating due to the magnetic contactor staying in the closed position.	See the 'Magnetic Contactor Troubleshooting' section.
Booster heater does not heat at all.	Main supply circuit breaker tripped.	Check and/or reset the circuit breaker.
	Booster heater circuit breaker tripped.	If unit is supplied with a circuit breaker, check and/or reset the circuit breaker.
	Booster in high limit.	If a high limit error occurs, allow water to cool and press the reset button. If error continues see symptom "Temperature and pressure relief valve opens and/or high limit temperature error occurs".
	Low water error.	Verify that booster heater is full of water. If error is still present see the 'P65 Probe Troubleshooting' section.
	Magnetic contactor does not energize.	See the 'Magnetic Contactor Troubleshooting' section.
	No power to control board (T1000) or display (TD1000) not lit.	Reseat the display (TD1000) ribbon cable in the control board (T1000) connector. If the display is still not lit, see the 'Control Board (T1000) / Display (TD1000) Troubleshooting' section.
	Element Failure	Disconnect the wires from each element and verify that the resistance (ohms) value for each element is correct. Replace elements as required.

CONTROL BOARD (T1000) / DISPLAY (TD1000) TROUBLESHOOTING

1. Verify proper power supply voltage between each phase (L1 to L2, L2 to L3, and L1 to L3). The power supply voltage should match the voltage listed on the booster nameplate. If voltage is incorrect, check main supply wiring or replace unit with proper booster heater.
2. Check for 208/240VAC between pin 1 (white wire) and pin 2 (black wire) of the J5 connector on the T1000 control board. If no voltage is present, skip to step 4.
3. If 240VAC is present, check for 24VDC between D1 and ground. If 24VDC is present replace the display (TD1000). If 24VDC is not present replace the control board (T1000).

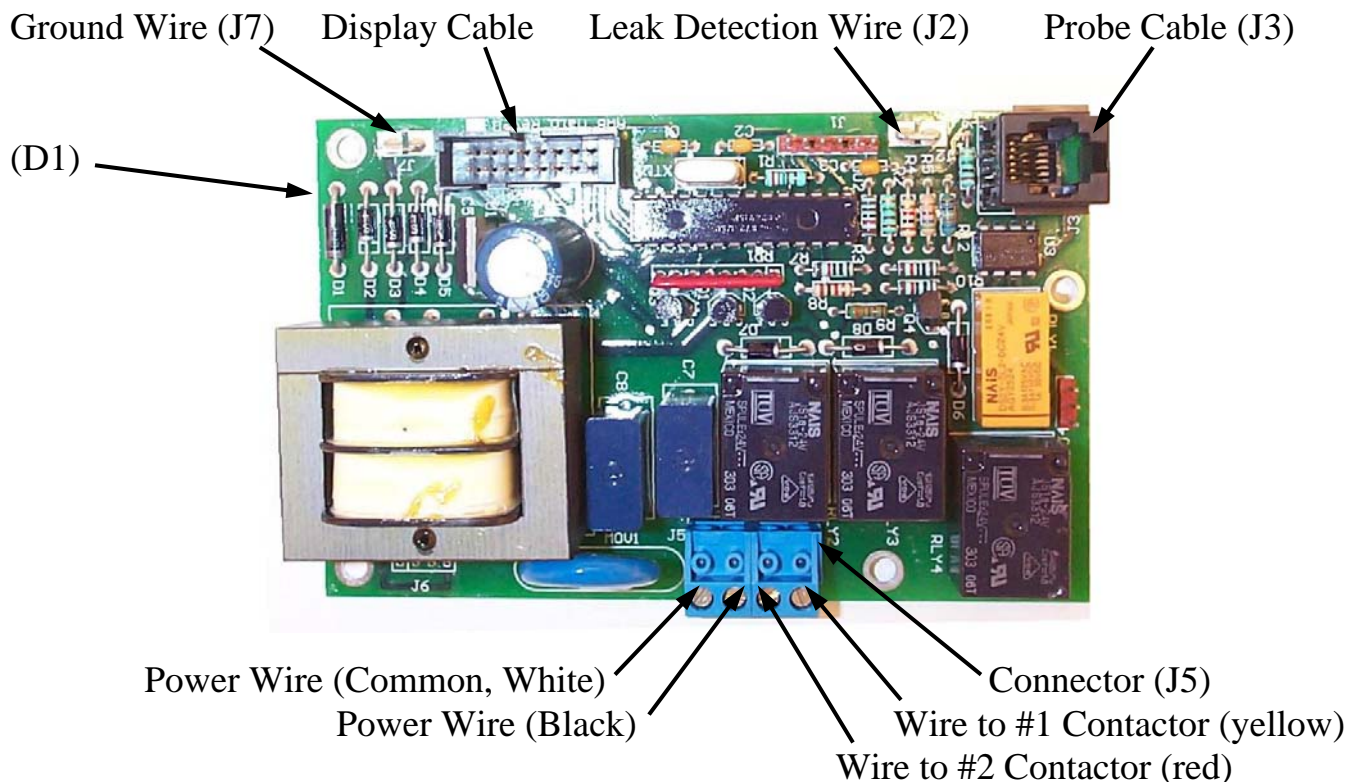

4. If a transformer is installed, verify proper power supply voltage to the primary side of the transformer and verify approximately 240VAC on the secondary side of the transformer. If voltage is present of the primary side but not on the secondary side, replace the transformer.
5. If circuit breakers are installed, verify that the circuit breaker is ON. Verify proper power supply voltage between each phase (L1 to L2, L2 to L3, and L1 to L3) to the line side of each circuit breaker and to the load side of each circuit breaker. If voltage is present of the line side but not on the load side, replace the circuit breaker.
6. Verify that the booster heater is wired according to the proper wiring schematic for the unit. Correct as required. If unit still does not operate, contact the factory.

MAGNETIC CONTACTOR TROUBLESHOOTING

1. With the unit ON and calling for heat, check for lit decimal points on the display. If the unit has a single contactor, the first decimal to the right of the display should be lit. If two decimals are lit, verify that the configuration is set for one contactor. If the unit has two contactors, verify that two decimals are lit. If only one decimal is lit, verify that the configuration is set for two contactors. If no decimals are lit, continue to the 'P65 Probe Troubleshooting' section.
2. With the unit ON and calling for heat and one decimal lit, check for 240VAC between pin 1 (white wire) and pin 4 (yellow wire) of the J5 connector on the T1000 control board. If no voltage is present, replace the control board (T1000). If voltage is present, check for voltage across the contactor coil. If voltage is present at the contactor coil, replace the magnetic contactor. If no voltage is present, verify that the booster heater is wired according to the proper wiring schematic for the unit.
3. If the unit has two contactors, with the unit ON and calling for heat and two decimals lit, check for 240VAC between pin 1 (white wire) and pin 3 (red wire) of the J5 connector

on the T1000 control board. If no voltage is present, replace the control board (T1000). If voltage is present, check for voltage across the contactor coil. If voltage is present at the contactor coil, replace the magnetic contactor. If no voltage is present, verify that the booster heater is wired according to the proper wiring schematic for the unit.

P65 PROBE TROUBLESHOOTING

1. Unplug and reseal the P65 probe wire in the jack on the T1000 control board. Note that the error message “Err, No, Prb” will be displayed and the reset button must be pressed to clear the message.
2. If problem persists, unplug the P65 probe from the control board and plug into the RJ45 pigtail (not supplied).
3. If the problem is with temperature control or high limit:
 - a. Change the configuration to ‘dSt’ to display the actual water temperature.
 - b. Check the temperature of the water with a thermometer and compare that with the temperature on the display. If the two temperatures coincide, replace the T1000 control board. If the two temperatures do not coincide, continue to the next step.
 - c. Unplug the P65 probe from the control board and plug into the RJ45 pigtail (not supplied). Check the resistance value (ohms) between the blue wire of the pigtail (#1) and the red wire of the pigtail (#4). Compare the resistance value measure with the chart below at the measured temperature of the water. If the two values coincide, replace the T1000 control board. If the two values do not coincide, replace the P65 sensor
4. If the problem is with low water:
 - a. Verify that the unit is filled with water.
 - b. Check for continuity between the yellow wire of the pigtail (#2) and ground. If continuity exists, replace the T1000 control board. If no continuity exists, replace the P65 sensor probe.

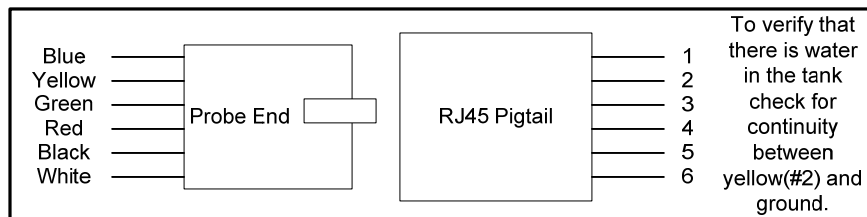

Thermistor Resistance vs. Temperature	
Water Temperature	Resistance (±3%)
70°F	11883Ω
80°F	9299Ω
90°F	7334Ω
100°F	5828Ω
110°F	4664Ω
120°F	3758Ω
130°F	3048Ω
140°F	2488Ω
150°F	2043Ω
160°F	1687Ω
170°F	1400Ω
180°F	1169Ω
190°F	980Ω

SECTION V – SERVICING AND REPLACEMENT OF PARTS

WARNING / CAUTION

Before servicing or replacing any part, make sure to turn the power supply to the unit OFF.

HEATING ELEMENT

1. Disconnect power from unit.
2. Shut off incoming water supply.
3. Attach hose to drain connection.
4. Lift manual release lever on relief valve to let air into system or break union on outgoing water line.
5. Drain water from tank.
6. Disconnect the wires from the heating element terminals.
7. Unscrew element with a 1-7/8" 6-point socket with no bevel.

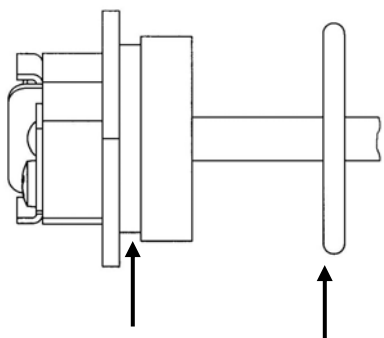

O-Ring Groove O-Ring

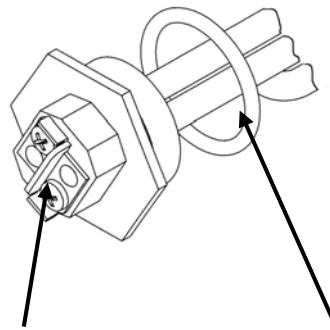

Terminal Connections #220 Buna-N O-Ring

8. Install new #220 Buna-N o-ring gasket and install new heating element. NOTE: Hubbell recommends lubricating the o-ring with Parker O-Lube prior to installation.
9. Rewire element according to the wiring diagram as shown in the Section II.
10. Fill tank and check around element for any leaks.

MAGNETIC CONTACTOR

1. Disconnect power from unit.
2. Disconnect line and load wires to contactor.
3. Disconnect the control circuit wires.

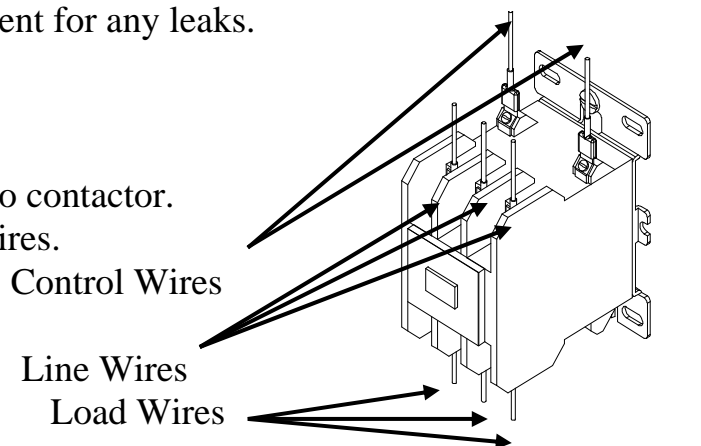

Mounting Screws

4. Loosen holding screws and remove contactor.
5. Replace with new contactor using reverse procedure.

CONTROL BOARD

1. Disconnect power from unit.
2. Disconnect display cable, probe cable (J3), leak detection wire (J2), ground wire (J7), and terminal block (J5) from the control board. NOTE: The terminal block (J5) is removable from the control board. Grasp the terminal block on the ends and pull straight away from the board.

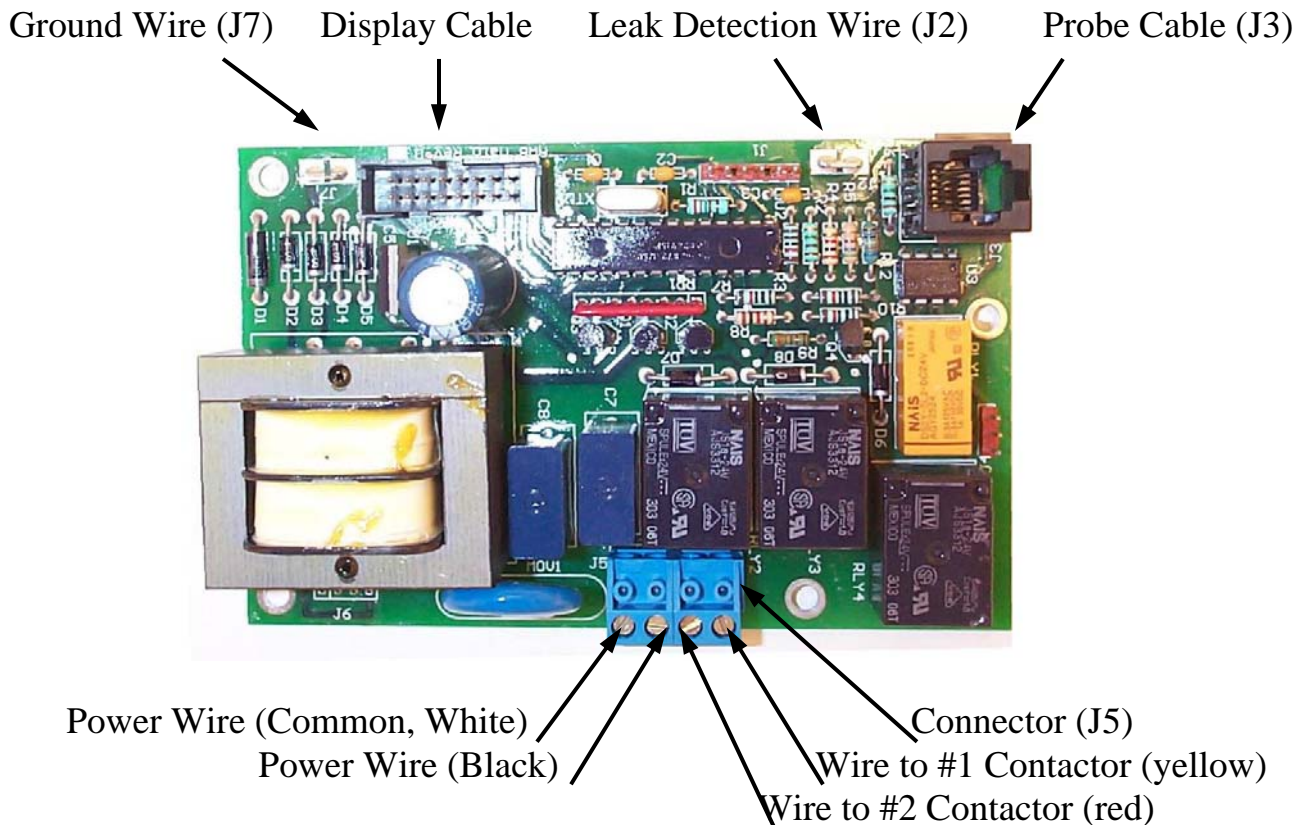

3. Remove four (4) screws securing control board to panel.
4. Remove and replace control board.
5. Reconnect wires disconnected in step 2. NOTE: When reconnecting the ribbon cable, be sure to have the key on the cable align with the slot in the connector.
6. Connect power to unit.

RELIEF VALVE

1. Disconnect power from unit.
2. Shut off incoming water supply.
3. Attach hose to drain connection.
4. Lift manual release lever on relief valve to let air into system or break union on outgoing water line.
5. Drain water from tank.
6. Disconnect overflow piping.
7. Unscrew relief valve, remove assembly and replace with new one.
8. Connect overflow piping.
9. Turn on incoming water supply and check for leaks.
10. Connect power to unit.

P65 SENSOR PROBE

1. Disconnect power from the unit.
2. Unplug the P65 probe connector from the T1000 control board.

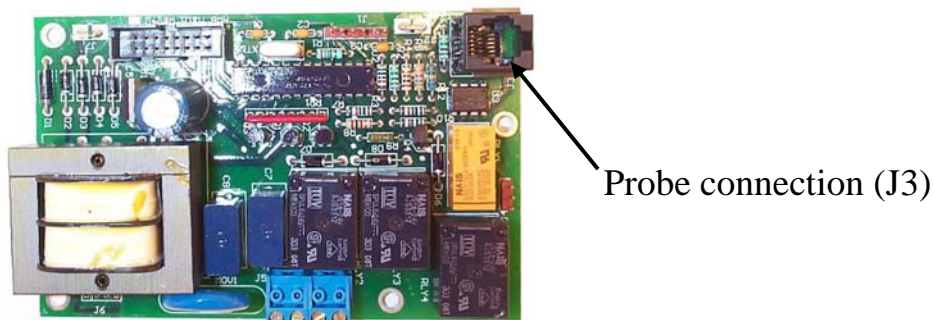

3. Twist the cord and shrink-wrap end of the P65 probe (or cut the shrink-wrap with a sharp knife) to loosen the P65 sensor assembly from the P65 thermowell.
4. Remove the old P65 sensor assembly by pulling on the cord coming out of the P65 thermowell.

Note: It is unnecessary to unscrew the thermowell from the vessel to replace the P65 sensor.

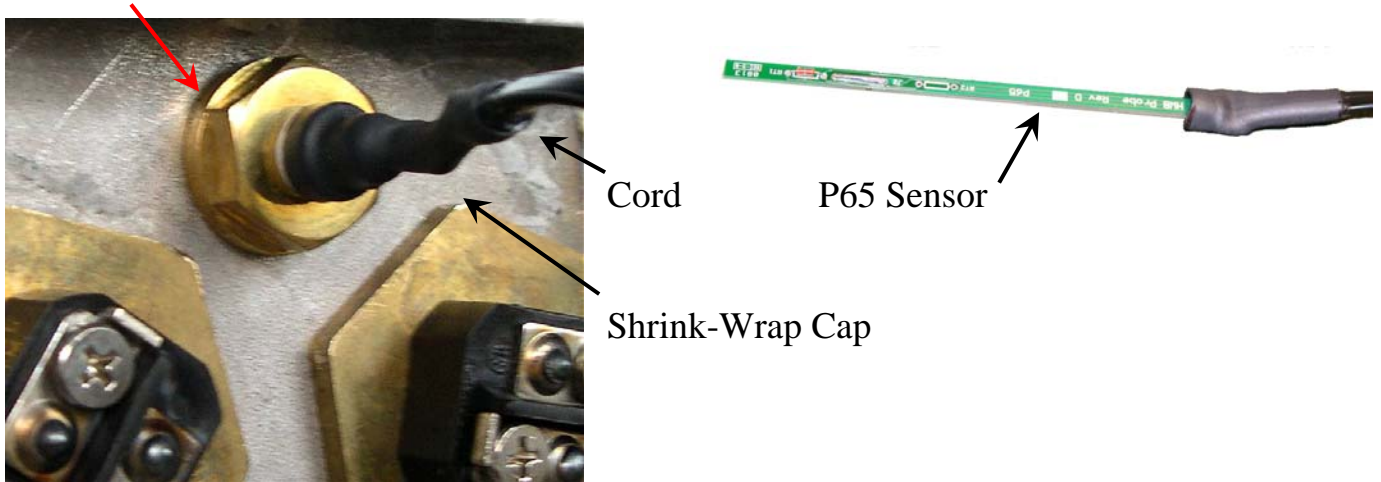

5. Insert the new P65 sensor assembly into the P65 thermowell. Be sure to insert the sensor until the shrink-wrap cap engages the threads on the end of the thermowell.

Note: The new sensor and cord assembly is push-fit onto the end of the thermowell threads. Do not twist the new sensor and cord assembly into the thermowell. The thermal conductive heat transfer paste inside the thermowell is sufficient for replacement sensors. Adding additional paste is not required.

6. Plug P65 probe connector into the T1000 control board.

7. Turn on power to the unit. If display shows “Err, No, Prb”, press the reset button.

P65 THERMOWELL

1. Follow steps 1-4 for removing the P65 Sensor Probe above.
2. Shut off incoming water supply.
3. Attach hose to drain connection.
4. Lift manual release lever on relief valve to let air into system or break union on outgoing water line.
5. Drain water from tank.
6. Remove the thermowell from tank using a 13/16” socket.
7. Install new #115 Buna-N o-ring gasket and install new thermowell. **NOTE:** Hubbell recommends lubricating the o-ring with Parker O-Lube prior to installation. **WARNING:** Do not remove the jam nut.

Thermowell

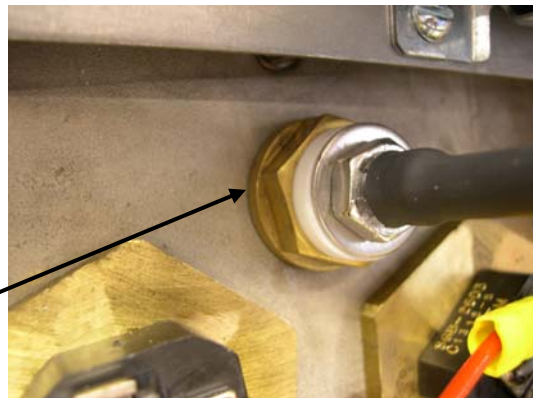

8. Reinstall or install a replacement P65 sensor probe in accordance with steps 5 and 6 above.

9. Refill tank.

10. Check for leaks. Retighten as required.

11. Turn on power to the unit.

12. Note that to resume operation the controller will need to be reset by pressing the ‘RESET’ button on the display.



CAUTION: Do not use plumber’s tape/Teflon tape/pipe dope when installing the P65 Thermowell. Tape will prevent the low water detection system from operating properly and will cause false low water errors. Lubricate O-ring prior to installation.

Tighten probe at the brass hex flats only.

SECTION VI – SERVICE PARTS LIST

Category	Description	Volts	Ohms	Hubbell P/N
Accessories	Bronze Pressure Reducing Valve			N45BU
	Plastic Legs (Price each, 4 Req'd.)			AP61-4003-C
	Nickel Plated Legs (Price each, 4 Req'd.)			AE61-4002-C
	Stainless steel adjustable legs (Price each)			A50-5048-C
	Floor Mount Legs S/S (Price each, 4 Req'd.)			A50-9939-C
	Temp. and Pressure Gauge			T405
	Dielectirc Union, 3/4"			DIELECTRIC UNION
	Relief Valve (up to 27 kw)			100XL .75 150LB
	Relief Valve (30-58 kw)			40XL-5 .75 150LB
	Relief Valve (64-90 kw)			40XL-4 1 150LB
	Slide Brackets (J6 models only, 2 per set)			J6 SLIDE BRACKET
	J6, 3 Element Plastic Protective Shroud (1 to 18 kW)			J6-3 SHROUD
	J6, 6 Element Plastic Protective Shroud (24 to 58.5 kW)			J6-6 SHROUD
	J16 Element Plastic Protective Shroud			J16 SHROUD
	Water Treatment System (blended phosphate)			HBW-CLEAR
	Replacement cartridge for water treatment			RSC-10
	Circuit Breakers	60 amp		
70 amp				CB 70 AMP
80 amp				CB 80 AMP
90 amp				CB 90 AMP
100 amp				CB 100 AMP
Contactors	20 Amp Resistive, 15 Amp Inductive, 208/240 VAC Coil			C25DNF315B
	40 Amp Resistive, 30 Amp Inductive, 208/240 VAC Coil			C25DNF330B
	50 Amp Resistive, 40 Amp Inductive, 208/240 VAC Coil			C25DNF340B
	65 Amp Resistive, 50 Amp Inductive, 208/240 VAC Coil			C25DNF350B
	75 Amp Resistive, 60 Amp Inductive, 208/240 VAC Coil			C25FNF360B
	90 Amp Resistive, 75 Amp Inductive, 208/240 VAC Coil			C25FNF375B
Elements J4, J6, and J16 (Note: Each element is supplied with an O-Ring)	2000 Watts	208	21.6	C1315-2
	4000 Watts	208	10.8	C1315-3
	5000 Watts	208	8.7	C1315-4
	6000 Watts	208	7.2	C1315-5
	6500 Watts	208	6.7	C2315-6
	7150 Watts	208	6.1	C2315-7
	9000 Watts	208	4.8	C2315-9
	9600 Watts	208	4.5	C2315-10
	2000 Watts	240	28.8	C1315-11
	3000 Watts	240	19.2	C1315-12
	3500 Watts	240	16.5	C1315-13
	4000 Watts	240	14.4	C1315-14
	4500 Watts	240	12.8	C1315-15
	5000 Watts	240	11.5	C1315-16
	6000 Watts	240	9.6	C1315-17
	6500 Watts	240	8.9	C1315-18
	6750 Watts	240	8.5	C1315-34
	7500 Watts	240	7.7	C2315-19
	9000 Watts	240	6.4	C2315-20
	9750 Watts	240	5.9	C2315-21
	2000 Watts	480	115.2	C1315-22
	2333 Watts	480	98.8	C1315-23
	3000 Watts	480	76.8	C1315-24
	3500 Watts	480	65.8	C1315-25
	4000 Watts	480	57.6	C1315-26
	4500 Watts	480	51.2	C1315-27
	5000 Watts	480	46.1	C1315-28
	6000 Watts	480	38.4	C1315-29
	6500 Watts	480	35.4	C1315-30
	7500 Watts	480	30.7	C1315-31
	9000 Watts	480	25.6	C1315-32
	9750 Watts	480	23.6	C1315-33
	6750 Watts	480	34.1	C1315-35
Extra O Ring (#220 Buna-N)			O RING J MODEL	
Elements J3 (Note: Each element is supplied with an O-Ring)	1900 Watts	120	7.6	SGB-2197
	3300 Watts	208	13.1	SGB-2337
	3460 Watts	208	17.6	SGB-2347
	3200 Watts	220	15.1	SGB-2327V
	3800 Watts	240	15.2	SGB-2387
	3800 Watts	277	20.2	SGB-2387V
	3800 Watts	346	31.5	SGB-2388V

SERVICE PARTS LIST (cont.)

Category	Description	Volts	Ohms	Hubbell P/N
Misc. Electrical	Control Board			T1000
	Digital Display Module (with overlay and J16 Extension)			TD1000
	J16 Ribbon Cable Extension			RIBBON CABLE J16
	Display Overlay			OVERLAY J MODEL
	Probe Sensor			P65
	Probe Thermowell (includes #115 Buna-N O-Ring)			P65 WELL
	Transformer 480-208V			B050-3299-3
	Transformer 600-195V			B050-3350-3
	Transformer 380-185V			B050-3351-3
	Transformer 480-208V (J3 and J4 only)			TRAN 480-208 25VA
	Transformer 380-208V (J3 only)			TRAN 380-208 25VA
	Transformer 277-208V (J3 only)			TRAN 277-208 25VA
	Transformer 600-208V (J3 only)			TRAN 600-208 25VA
	Power Distribution Block 175 amp 2 pole			16220-2
	Power Distribution Block 175 amp 3 pole			16220-3
	Power Distribution Block 310 amp 3 pole			16023-3
	Diffuser Assembly with Nipple			J6 DIFFUSER
	RJ45 Pigtail for P65 Probe Testing			P65-RJ45 TESTER
	Low Temperature Interlock			XB1
	24-Volt Interlock Adapter			PLUG ADAPTER J1
	Remote Alarm Plug Adapter			PLUG ADAPTER J4
	Wire #18 200C (black,white,red,yellow) Tefzel 750			WIRE #18 200C "COLOR"
	Wire #12 200C (blue or red) Tefzel 750			WIRE #12 200C "COLOR"
Wire #10 200C (blue or red) Tefzel 750			WIRE #10 200C "COLOR"	
Wire #8 200C (blue or red) Tefzel 750			WIRE #8 200C "COLOR"	
Wire #6 200C (black) Tefzel 750			WIRE #6 200C BLACK	
Vessel (includes insulation and o-rings)	J6 Vessel with 3 Element Openings			J6-3 TANK KIT
	J6 Vessel with 6 Element Openings			J6-6 TANK KIT
	J16 Vessel with 3 Element Openings			J16-3 TANK KIT
	J16 Vessel with 6 Element Openings			J16-6 TANK KIT
	J16 Vessel with 9 Element Openings			J16-9 TANK KIT
	J3 Vessel			J3 TANK KIT
J4 Vessel			J4 TANK KIT	
Stainless Steel Enclosure Parts	J6, 3 Element Base			J6-3 BASE
	J6, 3 Element Top Enclosure			J6-3 JACKET
	J6, 3 Element Front Cover			J6-3 FRONT COVER
	J6, 6 Element Base			J6-6 BASE
	J6, 6 Element Top Enclosure			J6-6 JACKET
	J6, 6 Element Front Cover			J6-6 FRONT COVER
	J16 Base			J16 BASE
	J16 Top Enclosure			J16 JACKET
	J16 Front Cover			J16 FRONT COVER
	J3 Base			J3 BASE
	J3 Top Enclosure			J3 JACKET
	J3 Front Cover			J3 FRONT COVER
	J4 Base			J4 BASE
	J4 Top Enclosure			J4 JACKET
J4 Front Cover			J4 FRONT COVER	

SECTION VII – TORQUE VALUES

Part	P/N	Wire Size	Torque (in•lbs)	Torque (ft•lbs)	
Element to Tank	All	N/A	600	50	
Wire to Element	All	All	15	1.25	
Probe to Tank	All	N/A	300	25	
Wire to Ground Lug	KA8C	All	25	2.08	
	KA4C	All	45	3.75	
Wire to Circuit Breaker	All	#14-#10	35	2.92	
		#8	40	3.33	
		#6-#4	45	3.75	
Transformer	All	All	15	1.25	
Wire to Control Board	All	All	3.5	0.29	
Wire to Contactor	C25DNF315B	#14-#12	15	1.25	
	C25DNF330B	#10	25	2.08	
	C25DNF340B	#8	40	3.33	
	C25DNF350B	#6-#4	45	3.75	
	C25FNF360B C25FNF375B	#14-#10	40	3.33	
		#8	45	3.75	
		#6-#4	50	4.17	
Wire to Power Distribution Block	16023-3 16023-2	Line	All	275	22.92
		Load	#14-#10	20	1.67
			#8	25	2.08
			#6-#4	35	2.92
	63133 63132	Line	#14-#8	50	4.17
			#6-2/0	120	10
		Load	#14-#10	20	1.67
			#8	25	2.08
#6-#4	35	2.92			
Control Board to Panel	All	N/A	10	0.83	
Display to Base	All	N/A	10	0.83	
All Other Components to Panel	All	N/A	20	1.67	

SECTION VIII – WARRANTY INFORMATION

LIMITED WARRANTY

1. PRODUCT WARRANTY. Hubbell warrants the booster heater it manufactures and its components (the "Product") to be free from defects in materials and workmanship, under normal use and service for the period of time identified below beginning from the date of installation, provided that the product is installed within three (3) months of date of shipment from Hubbell and when the Product is installed and maintained in accordance with Hubbell's written instructions (see operators manual for details). Owner must establish the Product's purchase date by means satisfactory to Hubbell in its sole discretion.

TANK and COMPONENTS: One (1) year parts and labor

TANK ONLY: Ten (10) years Non Pro-Rated

REPLACEMENT PARTS: Thirty (30) days parts only, no labor, from date of purchase

SUCH WARRANTIES DO NOT COVER:

- Product failure (including but not limited to the tank and/or heating elements) caused by liming, sediment buildup, chemical corrosion, chlorine corrosion, or freezing.
- Temperature setting adjustments, pressure reducing valve adjustments, resets, and plumbing leaks.
- Product misuse, tampering or misapplication, accidental damage, improper installation or the application of improper voltage.
- Costs incurred for shipping, delivery, handling, and/or administrative charges.
- For the tank warranty after the first year, all labor, shipping, installation costs, and components (other than the tank) are the responsibility of the owner.
- With respect to labor warranty within the first year, overtime, holiday, weekend or any other non-standard labor rate.
- Excessive and unreasonable labor rates and/or travel expenses as determined by Hubbell in its sole discretion.

THE FOREGOING WARRANTIES ARE EXCLUSIVE AND IN LIEU OF ANY OTHER WARRANTY, EXPRESSED OR IMPLIED, INCLUDING BUT NOT LIMITED TO ANY IMPLIED WARRANTY OR MERCHANTABILITY OR FITNESS FOR A PARTICULAR PURPOSE OR PATENT OR OTHER INTELLECTUAL PROPERTY RIGHT INFRINGEMENT.

2. LIMITATION OF REMEDIES AND DAMAGES. Hubbell's liability and Buyer's exclusive remedy hereunder will be limited solely, at Hubbell's option, to repair or replacement by a Hubbell authorized service agency (other than where Buyer is located outside of the United States or Canada, in which case Hubbell's liability and Buyer's exclusive remedy hereunder will be limited solely to replacement of part under warranty) with respect to any claim made within the applicable warranty period referred to above. Without limiting the generality of the foregoing, all warranty items shall be returned by Buyer, at its sole expense, to the nearest Hubbell-authorized service agency or to the Hubbell factory (45 Seymour Street Stratford, CT 06615) for replacement or repair. Hubbell reserves the right to accept or reject any such claim in whole or in part. Hubbell will not accept the return of any product without prior written approval from Hubbell, and all such approved returns shall be made at Buyer's sole expense. HUBBELL WILL NOT BE LIABLE, UNDER ANY CIRCUMSTANCES, FOR CONSEQUENTIAL OR INCIDENTAL DAMAGES, INCLUDING BUT NOT LIMITED TO LABOR COSTS OR LOST PROFITS RESULTING FROM THE USE OR INABILITY TO USE THE PRODUCTS OR FROM THE USE OF OR INABILITY TO USE THE PRODUCTS OR FROM THE PRODUCTS BEING INCORPORATED IN OR BECOMING A COMPONENT OF ANY OTHER PRODUCT OR GOODS.

NOTES



P.O. BOX 288
STRATFORD, CT 06615-0288
PHONE: (203) 378-2659
FAX: (203) 378-3593
INTERNET: <http://www.hubbellheaters.com/>