



Operation Manual
For
Sodir
Panini Machines

Models - Savoy, Panini, Majestic, Diablo



765 Westminster Street • Providence, Rhode Island 02903 • U.S.A.

Tel: (401) 273-3300

Fax: (401) 273-3328

www.equipex.com

e-mail: service@equipex.com



IMPORTANT SAFEGUARDS

When using electrical appliances, basic safety precautions should always be followed, including the following:

1. Read all the instructions before use.
2. Do not touch hot surfaces; use handles or knobs.
3. To avoid electric shock, **do not immerse the power cord, or any part of the unit**, in any liquid.
4. Close supervision is necessary when any appliance is used, especially around children.
5. Unplug appliance from the electrical outlet when not in use, and before cleaning. Allow appliance to cool before installing or removing any parts or accessories, and before cleaning.
6. Do not operate any appliance with a damaged cord or plug, or if appliance should sustain damage, or malfunction in any way. In this event, return appliance to the nearest authorized service facility for examination, repair or adjustment.
7. The use of accessories and/or attachments not recommended by the appliance manufacturer may cause injury or damage to the appliance, and may void your warranty.
8. Do not use outdoors.
9. Do not allow the power cord to hang over the edge of a table or counter, or to be exposed to hot surfaces, as damage may occur.
10. Do not place appliance on or near a burner, or in a heated oven.
11. To disconnect an appliance, **first** turn all controls to the 'off' position *then* unplug the power cord from the wall outlet.
12. Do not use appliance other than for its intended use.
13. SAVE THESE INSTRUCTIONS FOR LATER USE!

INTRODUCTION

The **SODIR PANINI GRILLS** — Models SAVOY, PANINI, MAJESTIC and DIABLO — are uniquely designed to offer quality cooking. These units are constructed of food service quality stainless steel, and use fine grain cast iron top and bottom cooking surfaces. The grills are versatile in application and easy to operate. The moveable top is spring counterbalanced with adjustable tension on the handle. Top and bottom heating elements are thermostatically controlled up to 570 F. The units come equipped with a removable front drip tray and a handy scraper. All models are available with grooved, flat or mixed grill plates.

Specifications:

Model	Electrical	NEMA Plug
SAVOY	120V, 1.75 KW, 14 Amps	5-15 P
PANINI	120V, 1.75KW, 14Amps 208/240V, 1PH, 3KW, 12/14 Amps	5-15 P 6-15 P
MAJESTIC	208/240V, 1PH, 4KW, 16/18 Amps	L6-30 P
DIABLO	208/240V, 1PH, 6.5KW, 24/27 Amps	6-50 P

OPERATION

Initial Set-up

The grill is shipped with an application of machine oil on the upper and lower grill plates. This oil will need to be removed prior to the seasoning process using a mild soap and water solution.

Before operating your **SODIR** Panini grill, we recommend that you season the surface of the grill plates with cooking oil or shortening. For seasoning, wipe cooking oil or shortening onto the upper and lower grill plates using a clean, lint-free cloth, or coat the plates with cooking oil spray. Turn the grill on with the ON/OFF switch(s) and set the thermostat(s) to 400° F. When the grill reaches the set temperature, the red indicator light will go out. Allow the grill to season for 10-15 minutes and then let the grill cool. It is normal for some smoke to appear during this process. Wipe off the excess oil using a clean, lint-free cloth. Repeat seasoning process at least one more time. Congratulations, your grill is now ready for use!

Preheating

After the grill plates have been properly seasoned, turn the grill on using the ON/OFF switch(s) (the green light(s) will go on) and turn the temperature control knob(s) to the desired temperature. The red light(s) will go on and stay on until the desired temperature is reached. The red light(s) will then go out. The preheat time will vary depending on the cooking temperature settings and the electrical specifications of your model. It will normally take 10-15 minutes for your grill to reach cooking temperature. After reaching the set temperature, the red light(s) will cycle on and off as the thermostat cycles, to maintain temperature. The green light(s) remain on until the unit is shut off with the power switch.

Cooking

SODIR Panini grills can be used for a wide variety of foods. Following are some suggested guidelines for foods frequently cooked on this grill. Cooking times will vary depending on the food products, temperature settings and desired results.

<u>Sandwich</u>	Temperature:	400-450° F
	Time:	2-3 minutes
<u>Wrap</u>	Temperature:	375-450° F
	Time:	1-2 minutes
<u>Chicken Breast</u>	Temperature:	475-500° F
	Time:	2-3 minutes
<u>Beef Steak</u>	Temperature:	475-550° F
	Time:	2.5-4.5 minutes
<u>Burger</u>	Temperature:	500-550° F
	Time:	2-4 minutes

Adjusting Handle Tension

WARNING: Disconnect (unplug) electrical power supply before servicing

Allow the grill to cool. Remove the spring protection cover at the top rear of the unit by pulling it up. With a flat head screwdriver, tighten or loosen the screws on the handle straps until the desired tension is achieved. There are four (4) screws for each top plate, two (2) on each side. Re-install the spring protection cover prior to use. *See attached drawing.*

PANINI GRILL REAR TOP VIEW

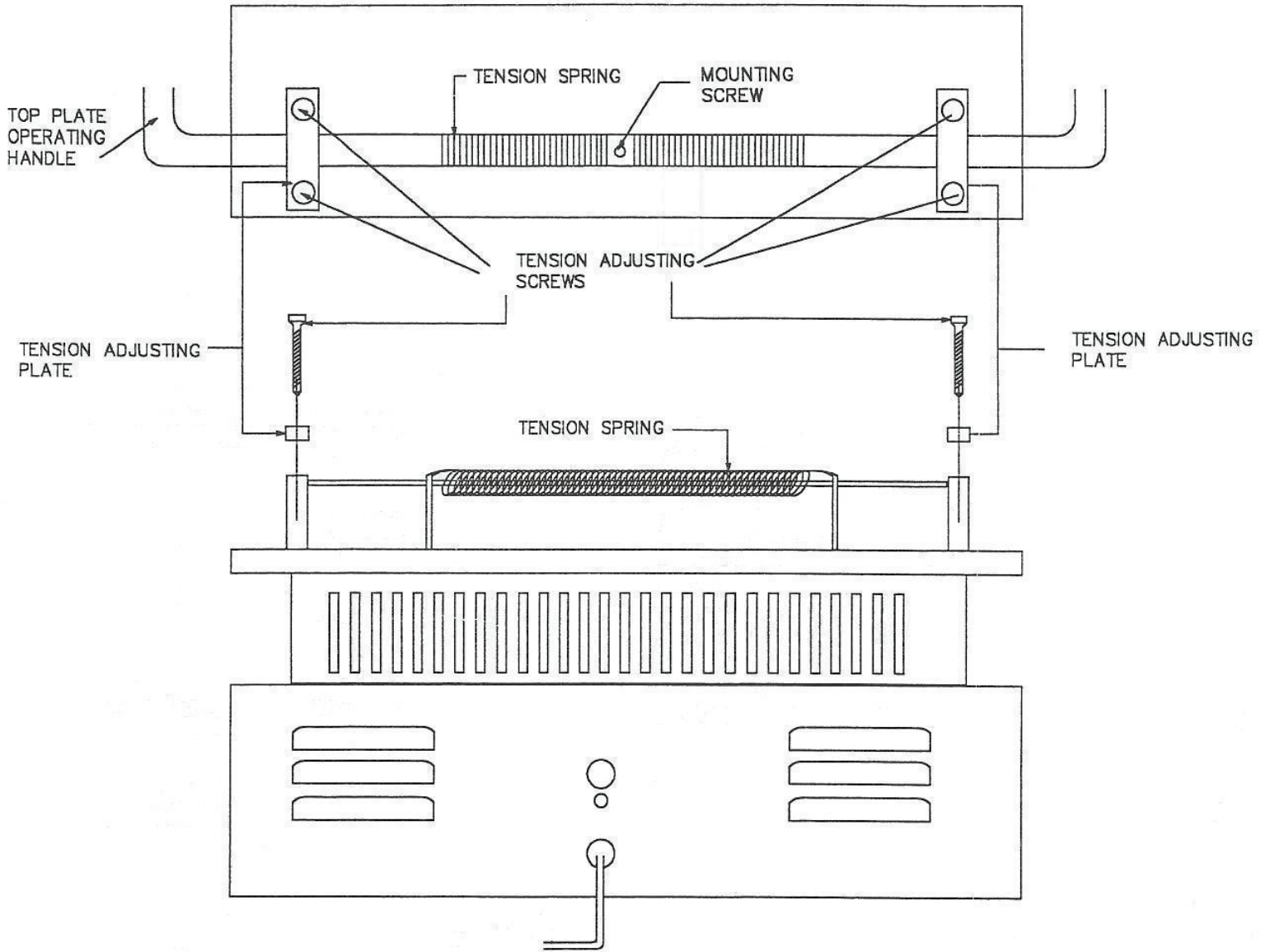

PANINI GRILL REAR VIEW

CLEANING

WARNING: Disconnect (unplug) electrical power supply before cleaning

Allow the grill to cool before cleaning. Using the scraper provided or a stiff wire brush, scrape the debris from the upper and then lower grill plates. To clean the grill, scrape or brush the debris toward yourself and into the removable drip tray. Use a cloth dampened slightly with a soap and water mixture to clean the stainless steel housing, upper grill covers, spring protection cover and the drip tray. Clean the grill thoroughly at the end of each day. Failure to do so may cause hard to remove build up. In order to remove the build up from the grill plates, use industry standard food service grade degreasers or grease removers. We do not recommend using soap and water to clean the grill plates, however, if soap and water are used, the grill will need to be re-seasoned (see below). For tough to remove carbon buildup, use a commercially available carbon remover.

DO NOT spray the unit with any cleaning liquid before unplugging it

DO NOT allow water to drip into the housing or around the electrical components

DO NOT immerse in water for cleaning

RESEASONING

It may be necessary to re-season the grill after extended use and cleaning. In order to do so, clean both plates of the grill with a clean, lint-free cloth and scraper. Apply cooking oil or shortening onto both plates with a lint-free cloth or coat the plates with a cooking oil spray. Wipe off excess oil with a dry, clean cloth. Turn the grill on and set the thermostat to 400 F. Some smoking may occur during the re-seasoning process. When the grill reaches the desired temperature (the red light will go out), turn the grill off and allow it to cool. Wipe off the excess oil from the surface of the plates. Repeat the re-seasoning process one more time. The grill is now re-seasoned and ready to use.

You should inspect all parts on a regular basis to ensure that all is in proper working order. If a part is damaged, have the unit repaired by an authorized service agency prior to returning the unit to operation. If you have trouble locating a service agency in your area, please consult our website at <http://www.equipex.com/>, or call us at 1-800-649-7885 and ask for customer service.

Please be advised that Models MAJESTIC and DIABLO are subject to on-site service under the terms of our warranty, while Models SAVOY and PANINI shall be carried-in for service.

Face Plate – Panini, Savoy

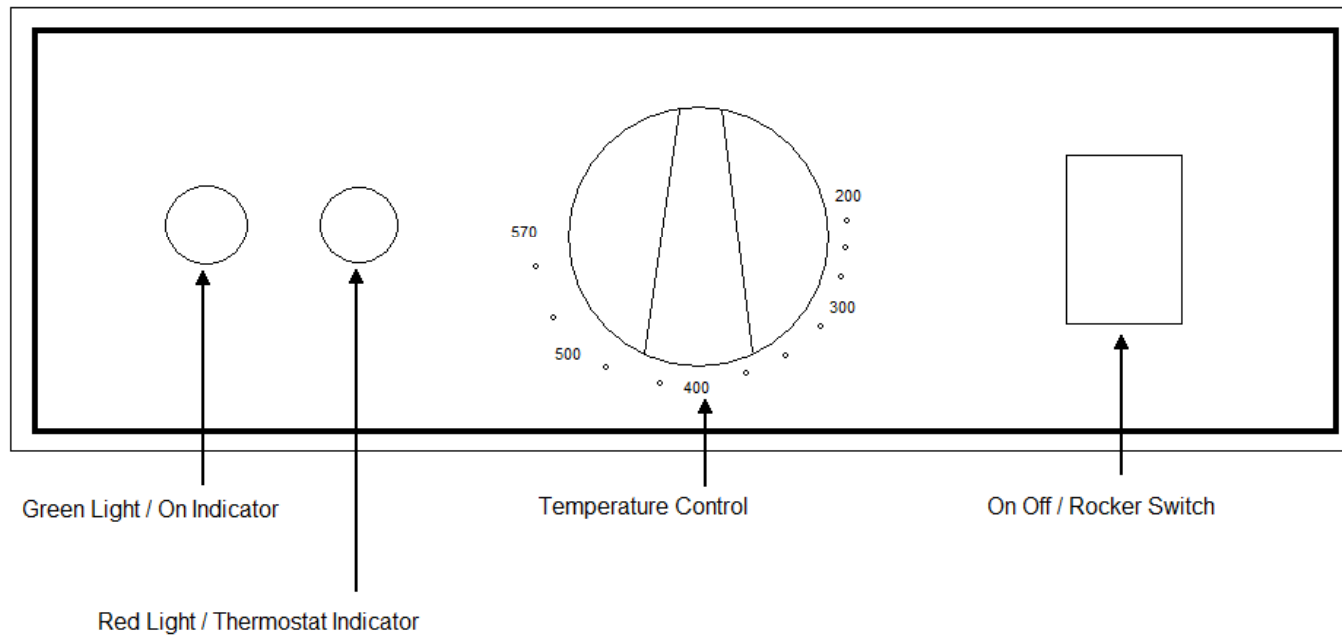

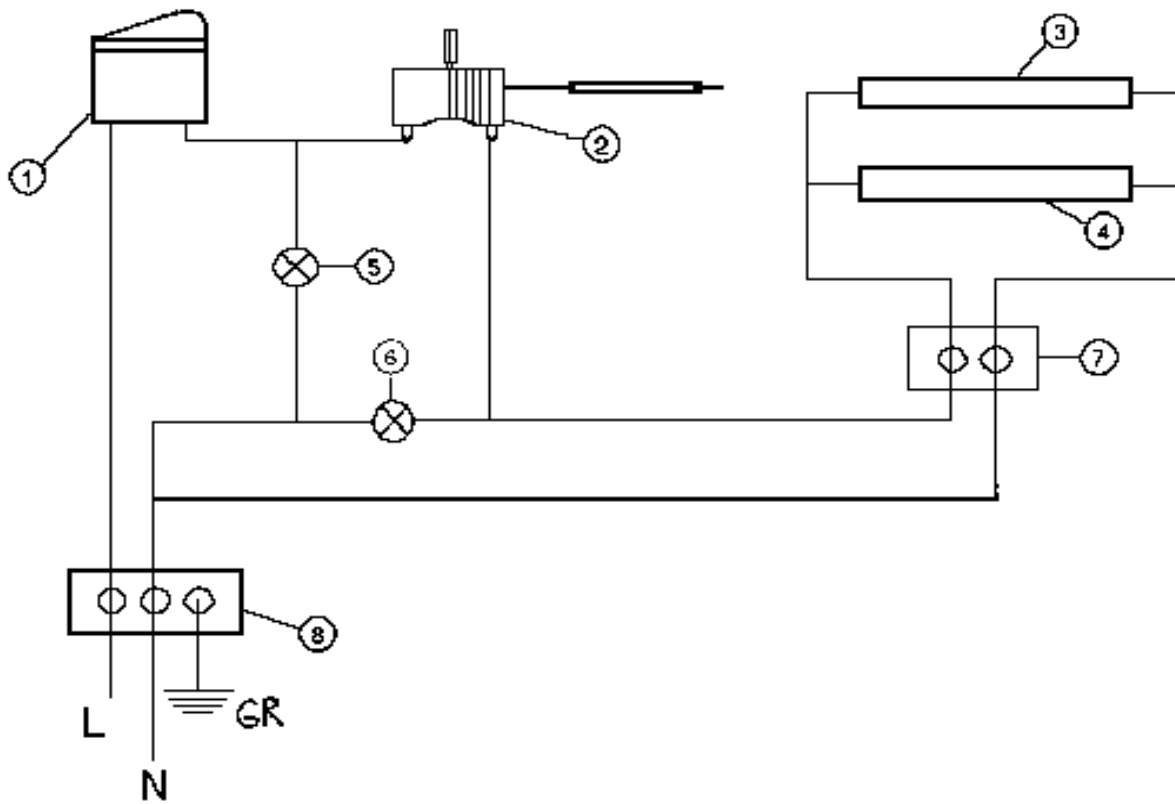

Savoy, Panini 120V

1	Switch
2	Thermostat
3	Top Heating Element
4	Bottom Heating Element
5	Green Pilot Light
6	Red Pilot Light
7	Two Hole Domino
8	Three Hole Domino

MODEL SAVOY

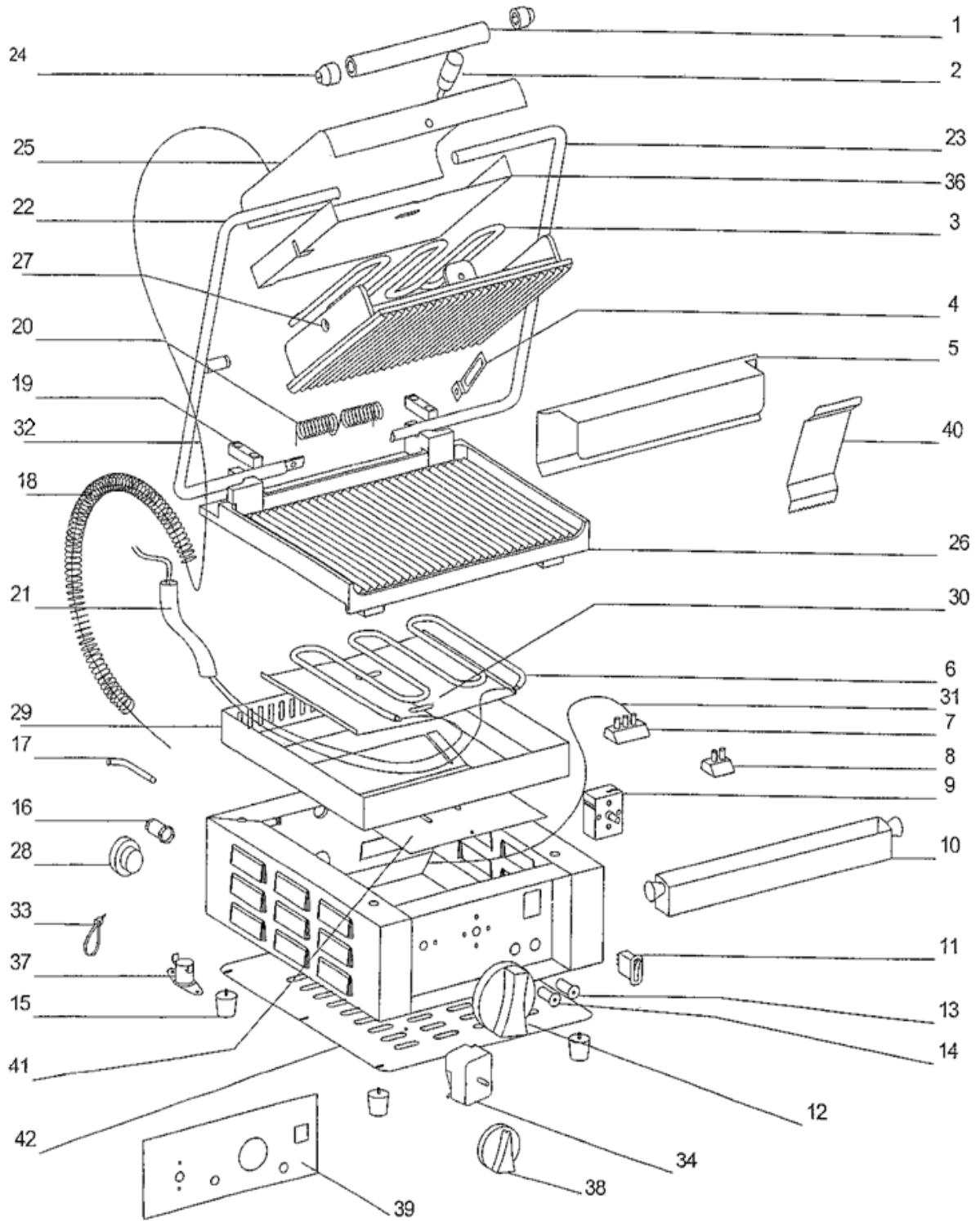

EQUIPEX, LLC				SPPAGR-SAV-03
765 Westminster Street, Providence, RI 02903				
Tel: (401) 273-3300 Fax: (401) 273-3328 Toll free : 1-800-649-7885				
SODIR Model SAVOY Panini Grill, 120V			Effective January 2004	
LIST OF SERVICE PARTS				
Drawing #	Part Number	Quantity	Description	Old Part Number
	B02020	1	Bottom Cast Iron Plate, Smooth	P-S202020
	B02034	1	Top Cast Iron Plate, Smooth	P-S202034
1	A15036	1	Black Insulated Handle	P-S115036
2	A15035	1	Top Plate Knob	P-S115035
3	D02043	1	Top Heating Element, 120V	P-S402113
4	37022 115	1	Top Plate Guide	P-S380050115
5	37006 308	1	Double Spring Cover	P-S380059108
6	D02088	1	Bottom Heating Element, 120V	P-S402112
7	A16013	1	Terminal Block, 3 position	P-S116013
8	A16012	1	Terminal Block, 2 position	P-S116012
9	A06032	1	Regulating Thermostat	P-S106032
10	37005P110	1	Drip Tray	P-S380044110
11	A07030	1	Switch, On/Off	P-S107030
12	A14078	1	Knob, Thermostat	P-S114078
13	A08002	1	Red Pilot Light, 120V	P-S108005
14	A08007	1	Green Pilot Light, 120V	P-S108011
15	A13003	4	Foot	P-S113003
16	A10010	1	Strain Relief	P-S110010
17	OEM0011	1	Power Cord, 120V (no plug)	P-S301002
18	C04005	1	Spring Girdle	P-S304005
19	B04034	2	Handle Strap	P-S204034
20	B07015	1	Double Torsion Spring	P-S207015
21	H02016	set	Insulating Sleeve	
22	F01041	1	Handle with Thread, Right	P-S601041
23	F01040	1	Handle w/o Threads, Left	P-S601040
24	B04033	2	Handle Tip	P-S204033
25	37021 510	1	Cover, Top	P-S37021 510
26	B02018	1	Bottom Cast Iron Plate, Grooved	P-S202018
27	802019	1	Top Cast Iron Plate, Grooved	P-S202019
29	37002 510	1	Middle Frame	P-S37002 510
30	37111X015	1	Bottom Element Pressure Plate	P-S37111 X015
34	OEM003	1	Timer, 5 minute, optional	P-SOEM003
36	37113X015	1	Top Element Pressure Plate	P-S37113X015
37	A06034	1	High Limit Thermostat	P-S106034
38	OEM0033	1	Timer Knob, optional	P-SOEM0033
40	37090 210	1	Scraper	
41	37002 510PL	1	Heat Shield	P-S37002 510PL
42	37003G008	1	Bottom Plate	P-S37003G008

MODEL PANINI

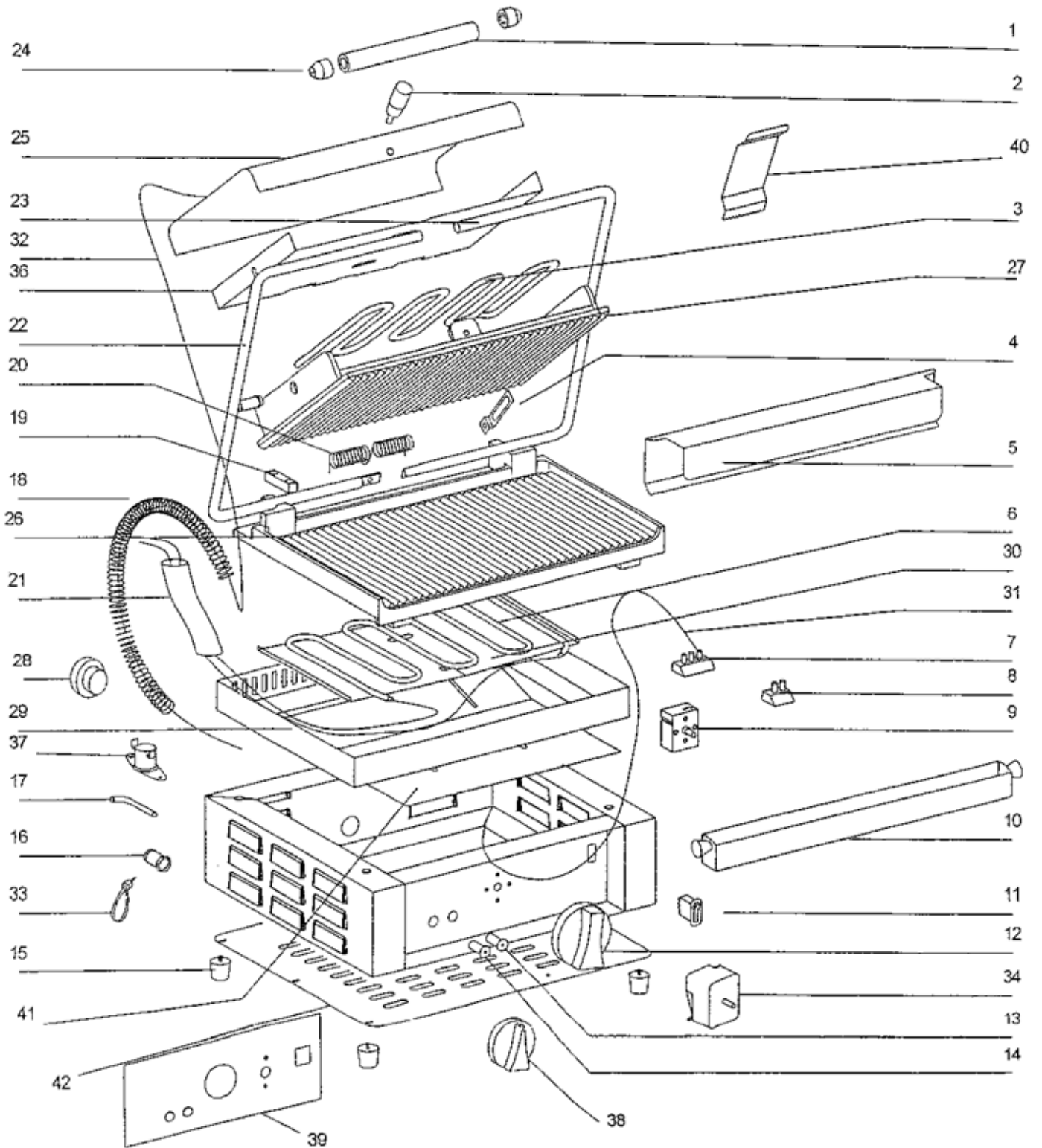

EQUIPEX, LLC			SPPAGR-PA-03	
765 Westminster Street, Providence, RI 02903				
Tel: (401) 273-3300 Fax: (401) 273-3328 Toll free : 1-800-649-7885				
SODIR Model PANINI Grill, 120V or 208/240V Effective January 2004				
LIST OF SERVICE PARTS				
Drawing #	Part Number	Quantity	Description	Old Part Number
1	A15036	1	Black Insulated Handle	P-S115036
2	A15035	1	Top Plate Knob	P-S115035
3	D02094	1	Top Heating Element, 220V	P-S402114
3	D02043	1	Top Heating Element, 120V	P-S402113
4	37022 115	1	Top Plate Guide	P-S380050115
5	37066 308	1	Double Spring Cover	P-S370059108
6	D02093	1	Bottom Heating Element, 220V	P-S402015
6	D02042	1	Bottom Heating Element, 120V	P-S402081
7	A16013	1	Terminal Block, 3 Position	P-S116013
8	A16012	1	Terminal Block, 2 position	P-S116012
9	A06032	1	Regulating Thermostat	P-S106032
10	37067P110	1	Drip Tray	P-S370044110
11	A07030	1	Switch, On/Off	P-S107030
12	A14078	1	Knob, Thermostat	P-S114076
13	A08008	1	Red Pilot Light, 220V	P-S108005
13	A08002	1	Red Pilot Light, 120V	P-S108005
14	A08009	1	Green Pilot Light, 220V	P-S108011
14	A08007	1	Green Pilot Light, 120V	P-S108011
15	A13003	4	Foot	P-S113003
16	A10010	1	Strain Relief	P-S110010
17	OEM0012	1	Power Cord, 220V (no plug)	P-S301002
17	OEM0011	1	Power Cord, 120V (no plug)	P-S301002
18	C04005	1	Spring Girdle	P-S304005
19	604034	2	Handle Strap	P-S204034
20	607015	1	Double Torsion Spring	P-S207015
21	H02016	set	Insulating Sleeve	
22	F01042	1	Handle with Thread, Right	P-S601042
23	F01043	1	Handle w/o Thread, Left	P-S601043
24	804033	2	Handle Tip	P-S204033
25	37064 510	1	Cover, Top	P-S370641510
26	B02023	1	Bottom Cast Iron Plate, Grooved	P-S202023
26	B02025	1	Bottom Cast Iron Plate, Smooth	P-S202025
27	B02024	1	Top Cast Iron Plate, Grooved	P-S202024
27	B02033	1	Top Cast Iron Plate, Smooth	P-S202033
29	37061 510	1	Middle Frame	P-S37061 510
30	37106X015	1	Bottom Element Pressure Plate	P-83706X015
34	OEM003	1	Timer, 5 minute	P-SOEM003
36	37105X015	1	Top Element Pressure Plate	P-S37105X015
37	A06034	1	High Limit Thermostat	P-S106034
38	OEM0033	1	Timer Knob	P-SOEM0033
40	37090 210	1	Scraper	P-S37090 210
41	37061 510PL	1	Heat Shield	P-S37061 510PL
42	37063G008	1	Bottom Plate	P-S37063G008

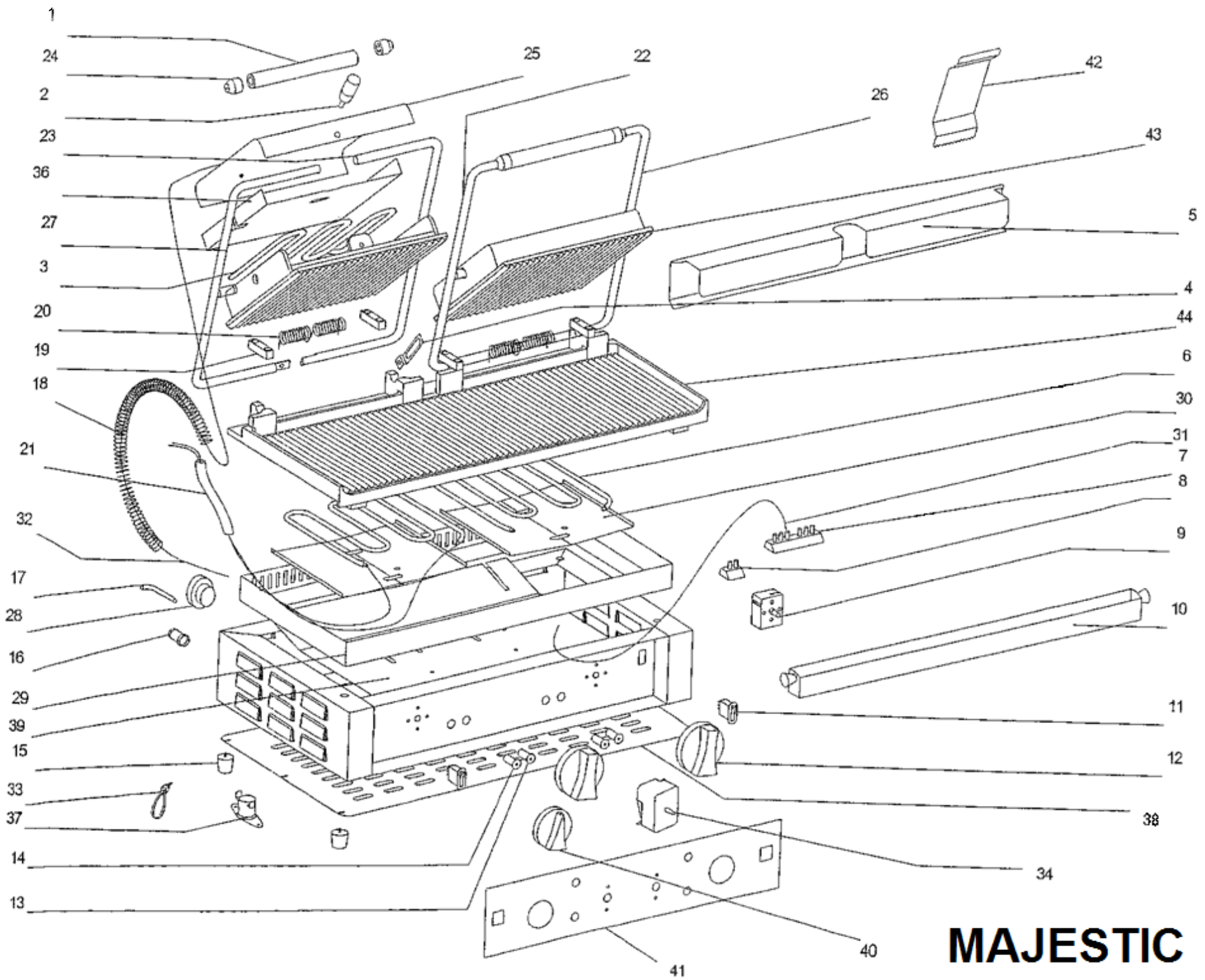

MAJESTIC

EQUIPEX, LLC				SPPAGR-MAJ-03
765 Westminster Street, Providence, RI 02903				
Tel: (401) 273-3300 Fax: (401) 273-3328 Toll free : 1-800-649-7885				
				Effective January 2004
SODIR Model MAJESTIC Panini Grill, 208/240V				
LIST OF SERVICE PARTS				
Drawing #	Part Number	Quantity	Description	Old Part Number
1	A15036	2	Black Insulated Handle	P-S115036
2	A15035	2	Top Plate Knob	P-S115035
3	D02096	2	Top Heating Element, 220V	P-8402080
4	37022 115	2	Top Plate Guide	P-5380050115
5	37046 308	1	Double Spring Cover	P-5390059108
6	D02095	1	Bottom Heating Element, 220V	P-S402079
7	A16014	1	Terminal Block, 6 position	P-S116014
8	A16012	2	Terminal Block, 2 position	P-S116012
9	A06032	2	Regulating Thermostat	P-S106032
10	37044P110	1	Drip Tray	P-S390044110
11	A07030	2	Switch, On/Off	P-S107030
12	A14078	2	Knob, Thermostat	P-S114078
13	A08008	2	Red Pilot Light, 220V	P-S108005
14	A08009	2	Green Pilot Light, 220V	P-S108011
15	A13003	4	Foot	P-S113003
16	A10010	1	Strain Relief	P-S110010
17	OEM001	1	Power Cord, 220V (no plug)	P-S301002
18	C04005	2	Spring Girdle	P-S304005
19	B04034	4	Handle Strap	P-S204034
20	607015	2	Double Torsion Spring	P-S207015
21	H02016	2	Insulating Sleeve	
22	F01027	1	Handle w/o Thread, Left (R-plate)	P-S6010273
23	F01020	1	Handle w/ Thread, Right (L-plate)	P-S601020
24	B04033	4	Handle Tip	P-S204033
25	37021 510	2	Cover, Top	P-S37021 510
26	F01040	1	Handle w/Thread, Right (R-plate)	P-S601040
27	F01041	1	Handle w/o Thread, Left (L-plate)	P-S601041
29	37043 510	1	Middle frame	P-S37043 510
30	37111X015	2	Bottom Element Pressure Plate	P-S37111X015
34	OEM003	2	Timer, 5 minute	P-SOEM003
36	37113X015	2	Top Element Pressure Plate	P-S37113X015
37	A06034	2	High-Limit Thermostat	P-S106034
38	37042G008	1	Bottom Plate	P-S37042G008
39	37043 510PL	1	Heat Shield	P-S37043 510PL
40	OEM0033	2	Timer Knob	P-SOEM0033
42	37090 210	1	Scraper	P-S37090 210
43	B02019L	1	Top Cast Iron Plate, Grooved, Left	P-S202019L
43	B02019R	1	Top Cast Iron Plate, Grooved, Right	P-S202019R
43	B02034L	1	Top Cast Iron Plate, Smooth, Left	P-S202034L
43	B02034R	1	Top Cast Iron Plate, Smooth, Right	P-S202034R
44	602017	1	Bottom Cast Iron Plate, Grooved	P-S202017
44	B02021	1	Bottom Cast Iron Plate, Smooth	P-S202021
44	B02022	1	Bottom Cast Iron Plate, Mixed	P-S202022

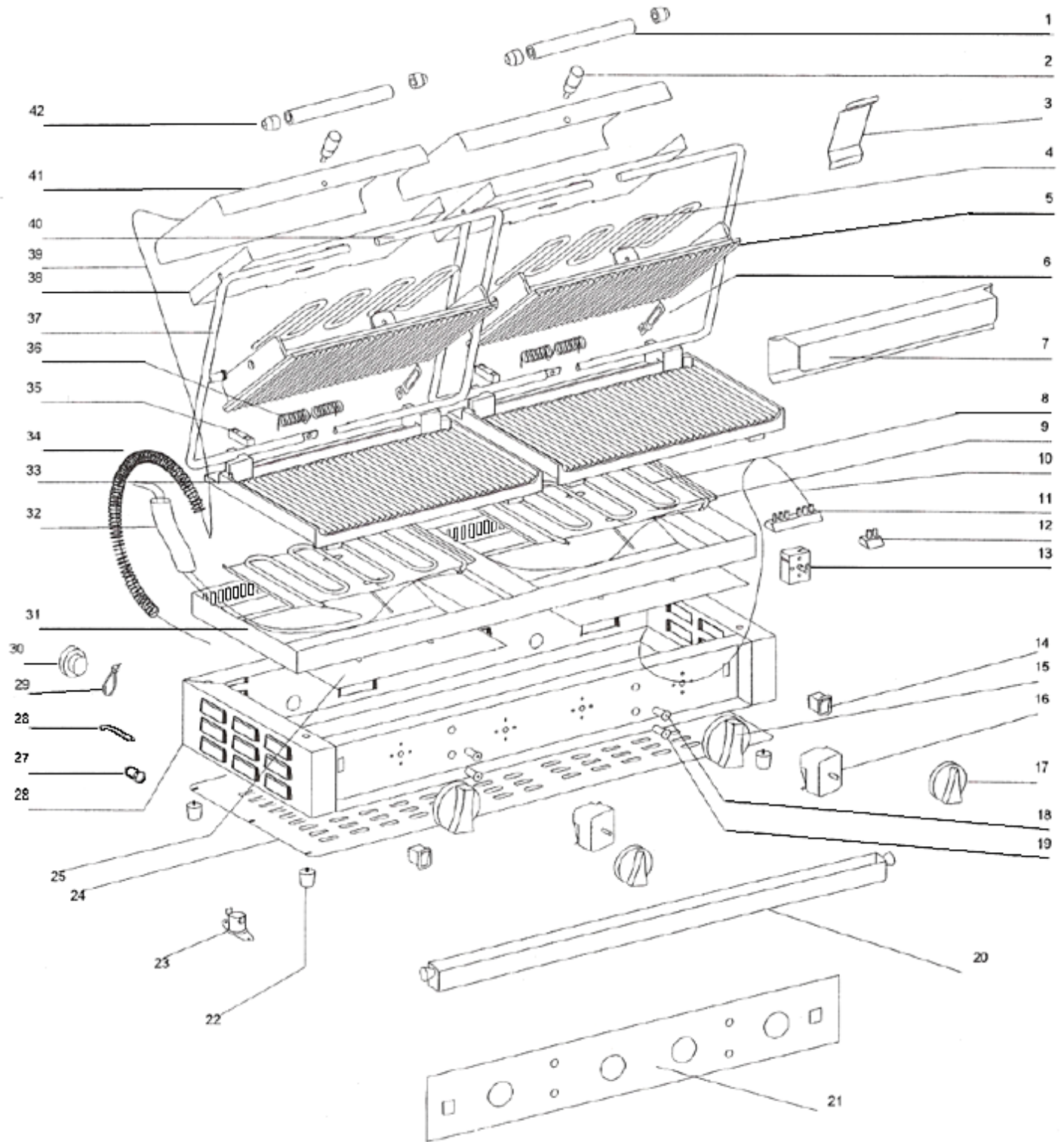

DIABLO – 208/240V

EQUIPEX, LLC				SPPAGR-DI-01
765 Westminster Street, Providence, RI 02903				
Tel: (401) 273-3300 Fax: (401) 273-3328 Toll free : 1-800-649-7885				
SODIR Model DIABLO Panini Grill, 208/240V				Effective
				January 2004
LIST OF SERVICE PARTS				
Drawing #	Part Number	Quantity	Description	Old P. N.
1	A15036	2	Black Insulated Handle	n/a
2	A15035	2	Top Plate Knob	P-S115035
3	37090I210	1	Scraper	P-S370901210
4	D02094	2	Top Heating Element, 220V	P-S402114
5	1302024PTR	2	Top Cast Iron Plate, Grooved	P-S202024
5	802033PTL	2	Top Cast Iron Plate, Smooth	n/a
6	37022 115	2	Top Plate Guide	P-S380050115
7	37066 308	2	Double Spring Cover	P-S370059108
8	D02093	2	Bottom Heating Element, 220V	P-S402015
9	37106X015	2	Bottom Element Pressure Plate	P-S3706X015
10	CO5016	1	Ground Wire	n/a
11	A16014	1	Terminal Block, 6 position	P-S116014
12	A16012	2	Terminal Block, 2 position	P-S116012
13	A06032	2	Regulating Thermostat	P-S106032
14	A07030	2	Switch, On/Off	P-S107030
15	A14078	2	Knob, Thermostat	P-S114078
16 (opt)	OEM003	2	Timer, 5 minute	P-SOEM003
17 (opt)	OEM0033	2	Timer Knob	P-SOEM0033
18	A08008	2	Red Pilot Light, 220V	P-S108005
19	A08009	2	Green Pilot Light, 220V	P-S108011
20	37165P110	1	Drip Tray	n/a
21	G06287	1	Faceplate	n/a
22	A13003	4	Foot	P-S113003
23	A06034	2	High-Limit Thermostat	P-S106034
24	37167G010	1	Bottom Plate	n/a
25	37164 308PL	1	Heat Shield	n/a
26	37166CE1	1	S/S Base	n/a
27	A10010	1	Strain Relief	P-S110010
28	OEM0052	1	Power Cord, 220V (no plug)	n/a
29	A10029	1	Wire Ties	n/a
31	37164 308CA	1	Middle Frame	n/a
32	C04007	set	Insulating Sleeve	
33	B02023PTR	2	Bottom Cast Iron Plate, Grooved	n/a
33	B02025PTL	2	Bottom Cast Iron Plate, Smooth	n/a
34	C04005	2	Spring Girdle	P-S304005
35	B04034	4	Handle Strap	P-S204034
36	B07019	2	Double Torsion Spring	n/a
37	F01043	2	Handle w/o Thread, Left	P-S601043
38	37105X015	2	Top Element Pressure Plate	P-S37105X015
39	CO5016	2	Ground Wire	n/a
40	F01042	2	Handle with Thread, Right	P-S601042
41	37064I308	2	Cover, Top	n/a
42	B04033	4	Handle Tip	P-S204033



LIMITED WARRANTY

Your new **EQUIPEX** product is warranted to the original purchaser for a period of one year from the date of purchase.

This limited warranty is against defects from original factory imperfections in material and/or workmanship and includes labor for replacement of defective parts, provided repairs are performed by an authorized service agency. Our obligation under this warranty is limited to repairing or replacing any part or parts thereof. The CUSTOMER must inform the Service Agency of warranty coverage and provide a copy of the dated sales or delivery receipt BEFORE WARRANTY REPAIRS BEGIN. Replacement parts and accessories are warranted for ninety (90) days from the date of purchase when purchased separately and will be verified by dated sales receipt or packing slip for that item. All parts or accessories replaced under warranty must be returned to the Service Agency.

This warranty applies only to equipment under normal use and service in the U.S.A. and Canada. It does not apply to any item which has been repaired or altered in any way so as, in the judgment of EQUIPEX, to affect its reliability.

THE FOLLOWING ARE NOT COVERED UNDER WARRANTY:

1. Damage caused by abuse, misuse or dropping or other similar incidental damage caused by, or as a result of, customer failure to follow assembly, operation, cleaning, user maintenance or storage instructions.
2. Labor to replace inoperative parts such as bulbs, plugs or racks due to normal wear and tear or abuse.
3. Materials or labor to repair scratched, stained, chipped, pitted, dented or discolored surfaces, attachments or accessories.
4. Transportation charges to or from a service agency for repair of your machine. If you should have questions relating to this issue, please call **Equipex** at 1-800-649-7885.
5. Labor charges to install or test attachments or accessories, which are replaced for any reason.
6. SHIPPING DAMAGES. Visible and hidden damages are the responsibility of the freight carrier. The consignee must file the claim promptly against the carrier. KEEP ALL ORIGINAL CONTAINERS AND PACKAGING MATERIAL FOR CARRIER INSPECTION.
7. Products placed or stored in the equipment are not subject to this warranty and no responsibility is assumed thereof.

THIS WARRANTY IS GIVEN EXPRESSLY AND IN LIEU OF ALL OTHER WARRANTIES, EXPRESSED OR IMPLIED, FOR MERCHANTABILITY AND FOR FITNESS TOWARD A PARTICULAR PURPOSE AND CONSTITUTES THE ONLY WARRANTY MADE BY EQUIPEX, LLC. IT NEITHER ASSUMES, NOR AUTHORIZES ANY PERSON TO ASSUME FOR US, ANY OTHER LIABILITY IN CONNECTION WITH THE SALE OF THE SUBJECT EQUIPMENT.

For service, please call **EQUIPEX** at 1-800-649-7885, menu option # 3

765 Westminster Street • Providence, Rhode Island 02903 • U.S.A.

Tel: (401) 273-3300

Fax: (401) 273-3328

www.equipex.com

e-mail: service@equipex.com