

VICTORY

110 Woodcrest Road, Cherry Hill, NJ 08003-3648
856.428.4200 • 800.523.5008 • Fax: 856.428.7299
www.victoryrefrigeration.com • email: sales@victoryrefrigeration.com



PROJECT: _____

LOCATION: _____

ITEM #: _____

QUANTITY: _____

ULTRASPEC™ SERIES

DUAL TEMPERATURE WINE COOLER



V-TEMP CONTROL™

STANDARD FEATURES

- V-TEMP™ Electronic Control System
- High Performance, Balanced, Top-Mounted Refrigeration
- R-134a Refrigerant
- Energy Efficient, EC Evaporator Fan Motor(s) (2-Section only)
- Plasticized Evaporator Fin Coils
- Non-Electric Condensate Evaporator
- Foamed-in-Place Polyurethane Insulation
- Insulated Partition Wall Separates Compartments
- Heavy Duty Cylinder Locks
- Self-Closing Doors with 120° Hold Open Feature
- Cam-Lift Hinges, Guaranteed for Life
- Ergonomically Correct Door Handles, Guaranteed for Life
- 6" High, Adjustable Stainless Steel Legs
- Hinged Front Shroud Makes Condenser Cleaning Easier
- Proximity Door Switch Activates Interior Lighting
- One Piece, Snap-In Magnetic Door Gasket(s)
- Anti-Condensate Door Perimeter Heaters
- LED Lighting
- Energy Saving Thermal Breaker Caps, Guaranteed for Life
- Fully Extractable Wine Racks
- Cord and Plug (see electrical data for details)

OPTIONS AND ACCESSORIES

- Remote Models
- Stainless Steel Case Back and Shroud
- 6" Overall Height Casters
- Optional Voltages
- USB Data Recorder
- RS-485 Serial Interface



WCDT-2D-S1

MODELS

S
SERIES

Stainless Steel
Exterior and Interior

WCDT-1D-S1
WCDT-2D-S1



NOTE: Not all marks refer to all models

3 Year Parts and Labor Warranty • 5 Year Compressor Warranty

Victory Refrigeration specification sheets are available
online at www.victoryrefrigeration.com

APPROVALS:

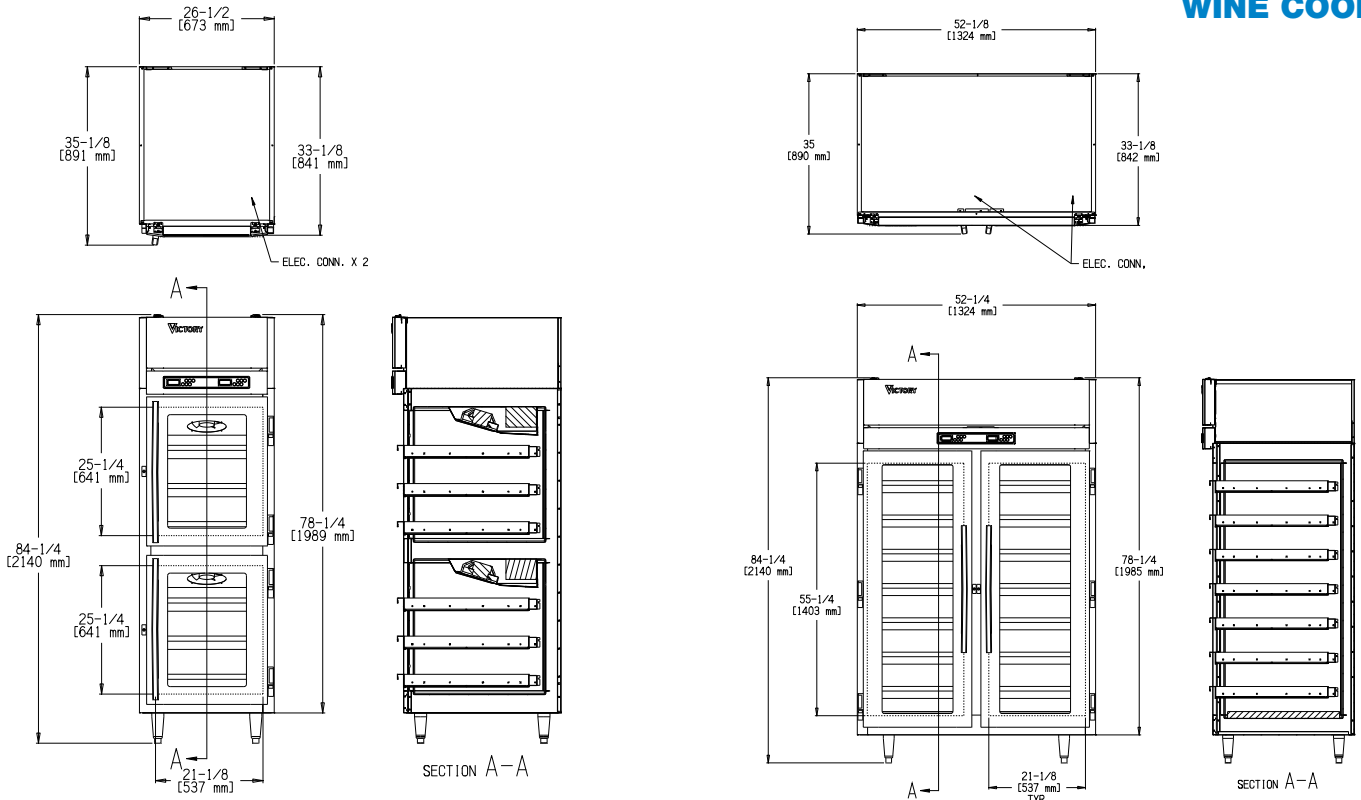

We reserve the right to change specifications and product design without notice. Such revisions do not entitle the buyer to corresponding changes, improvements, additions or replacements for previously purchased equipment.

Dimensional tolerances +/- 1/4". Metric dimensions (MM)

CABINET CONSTRUCTION

The cabinet front and doors are constructed of heavy gauge, polished stainless steel to maintain an attractive appearance after years of heavy use. Polyurethane foam insulation throughout ensures the ultimate in energy efficiency. The front shroud lifts up for easy access when cleaning the condenser unit.

DOOR CONSTRUCTION

Each glass door is provided with a cylinder lock and ergonomically correct vertical handle. The door hinges are self-closing and have a hold-open feature at 120° which facilitates product loading. Humidity control wires around the door jamb prevent condensation from forming on the front of the cabinet in high humidity environments.

REFRIGERATION SYSTEM

High efficiency, air-cooled, self-contained refrigeration systems are provided. The evaporator coils for both compartments are ceiling mounted on the single section model. The two section model has a top mounted system with the evaporator coils located outside the food storage zone. Environmentally friendly R-134a for the refrigerator is efficiently metered by capillary systems providing a constant, safe operating temperature and quick "recovery" under the most demanding conditions. The hermetically sealed systems are designed to operate from 40°F and 60°F. Each cooling coil has plasticized fin coils to resist food acids and dual-speed EC fan motor(s) for greater cooling capacity and efficiency. All condensate water is disposed of automatically by the condensate vaporizer on the single section and disposed of automatically with the non-electric hot gas disposal system on the two section model.

INTERIOR STORAGE ARRANGEMENTS

WCDT-1D-S1 – 3 fully extractable wine racks in each temperature zone for a total capacity of 60 bottles.
 WCDT-2D-S1 – 10 bottles each, for a capacity of 80 bottles per section (160 bottle total capacity).

V-TEMP™ CONTROL SYSTEM

The easy to use V-TEMP™ Control is provided standard. This durable, water resistant microprocessor monitors and controls the entire temperature maintenance process. It includes an ON/OFF switch, manual defrost, interior light switch, LED temperature indicator in °C or °F, a HI/LO audio/visual temperature alarm, power supply interruption, door ajar and "clean condenser" alarms. A manager's "lock-out" feature is provided to safeguard pre-determined control settings. A HACCP Event Indicator/Memory feature announces and records up to nine (9) alarm events. Unique to the V-TEMP™ are two standard modes of operation:

- ▶ **SUPERCOOL** - Provides a lower "set-point" refrigeration condition for a set period of time when food has just been loaded into the refrigerator and needs to be quickly brought back down to a safe temperature.
- ▶ **ENERGY SAVING** - The cabinet automatically reverts to the energy saving mode when there are no door openings for four hours.

CHARACTERISTICS

DIMENSIONAL DATA

Capacity Net (cubic ft.) Ref. 1 8.1
 Capacity Net (cubic ft.) Ref. 2 8.1
 Width, Overall (in.) 26 1/2
 Depth, Overall (inc. handles) 35
 Depth, Door(s) Open 90° (in.) 56 3/4
 Clear Door Width (in.) 21 1/8
 Clear Half-Door Height (in.) 25 3/8
 Clear Full-Door Height (in.) N/A
 Height Overall (inc. 6" legs) 84 1/4
 No. Full/Half Doors 2H
 No. of Full Extension Shelves 6
 No. of Fixed Shelves N/A

ELECTRICAL DATA

Cabinet Voltage 115/60/1
 Feed Wires Ref. 1 & 2 2
 Condensing Unit Voltage Ref. 115/60/1
 Total Amperes, Refrigerator 1 5.5
 Total Amperes, Refrigerator 2 10.7
 NEMA Plug 5-15P (2)

REFRIGERATION DATA

Condensing Unit Size, Refrigerator 1 1/4 HP
 Condensing Unit Size, Refrigerator 2 1/4 HP
 Refrigerant, Refrigerator R-134a

1 SECTION

8.1
 8.1
 26 1/2
 35
 56 3/4
 21 1/8
 25 3/8
 N/A
 84 1/4
 2H
 6
 N/A
 115/60/1
 2
 115/60/1
 5.5
 10.7
 5-15P (2)

2 SECTION

21.5
 21.5
 52 1/8
 35
 56 3/4
 21 1/8
 25 3/8
 55 1/4
 84 1/4
 2F
 14
 2
 115/60/1
 2
 115/60/1
 5.6
 5.6
 5-15P (2)
 1/4 HP
 1/4 HP
 R-134a

NOTE: Plug style, voltage and full load amps may vary depending on certain options selected such as optional voltages and compressor upgrades.

REMOTE APPLICATIONS: See form V-RRDS1 for details of remote refrigeration characteristics by model

CRATED DIMENSIONS & WTS.	HT.	WIDTH	DEPTH	FT ³	LBS
ONE SECTION	84 1/2	36	43	75.70	595
TWO SECTION	84 1/2	59 1/4	43	124.59	890

NOTE: In order to provide peak operating performance the cabinet must have a 2 inch all around clearance and 12 inches above the top of the condensing unit. This ensures an adequate air supply and space for routine maintenance and/or service if required.