

VICTORY

3779 Champion Blvd – Winston-Salem, NC 27105
888.845.9800 • Fax: 800.253.5168

www.victoryrefrigeration.com • email: sales@victoryrefrigeration.com

PROJECT: _____
LOCATION: _____
ITEM #: _____
QUANTITY: _____

ULTRASPEC™ SERIES

REACH-IN REFRIGERATORS

Featuring: **SecureTemp**
1.0™

STANDARD FEATURES

- Secure-Temp 1.0™ Technology
- V-TEMP™ Electronic Control System
- LED lights with proximity door switch, activates interior lighting
- Expansion Valve Technology
- 20 gauge, stainless steel doors
- Dual speed, energy efficient, EC fan motors
- Santoprene door gaskets with exclusive 2 year warranty
- Stainless steel breaker strips
- High Performance, Balanced, Top-Mounted Refrigeration
- Environmentally Safe R-134a Refrigerant
- Energy Efficient, Dual-Speed EC Evaporator Fan Motor(s)
- Plasticized Evaporator Fin Coils
- Non-Electric Condensate Evaporator
- Foamed-in-Place Polyurethane Insulation
- Heavy Duty Cylinder Locks
- Self-Closing Doors with 120° Hold Open Feature
- Cam-Lift Hinges, Guaranteed for Life
- Ergonomically Correct Door Handles, Guaranteed for Life
- S, SA Series have 6" High, Adjustable Stainless Steel Legs
- Hinged Front Shroud Makes Condenser Cleaning Easier
- One Piece, Snap-In Magnetic Door Gasket(s)
- Anti-Condensate Door Perimeter Heaters
- Stainless Steel Interior Door Liner
- Three (3) Epoxy Coated Wire Shelves per Cabinet Section
- Cord and Plug (see electrical data for details)



SECURE-TEMP 1.0™

Secure-Temp 1.0™ is the industry's first and only full service temperature monitoring solution for your kitchen. Secure-Temp 1.0™ is standard on all Victory models and is HACCP compliant and meets NAFEM's data protocol. There is NO software or monthly monitoring fees. Optional add on kits are available for additional units in your kitchen that you want to monitor.

OPTIONS AND ACCESSORIES

- Change Door Swing
- Remote Models
- Correctional Facilities Options
- Stainless Steel Case Back and Shroud
- Stainless Steel Shelves
- 6" Overall Height Casters (Set of 4)
- Exterior Laminate Décor
- Adjustable Tray and Pan Slides
- Optional Voltages
- **FLEXTEMP** Performance Mode



Please refer to www.energystar.gov to view the most up-to-date product listing and performance data.

NOTE: Not all marks refer to all models

3 Year Parts and Labor Warranty • 5 Year Compressor Warranty

MODELS



Stainless Steel Exterior and Interior

LONG-DOOR

RS-1D-S1
RS-2D-S1
RS-3D-S1

HALF-DOOR

RS-1D-S1-HS
RS-2D-S1-HS
RS-3D-S1-HS



Stainless Steel Exterior and Aluminum Interior

RSA-1D-S1
RSA-2D-S1
RSA-3D-S1

RSA-1D-S1-HS
RSA-2D-S1-HS
RSA-3D-S1-HS

Victory Refrigeration specification sheets are available online at www.victoryrefrigeration.com

APPROVALS:

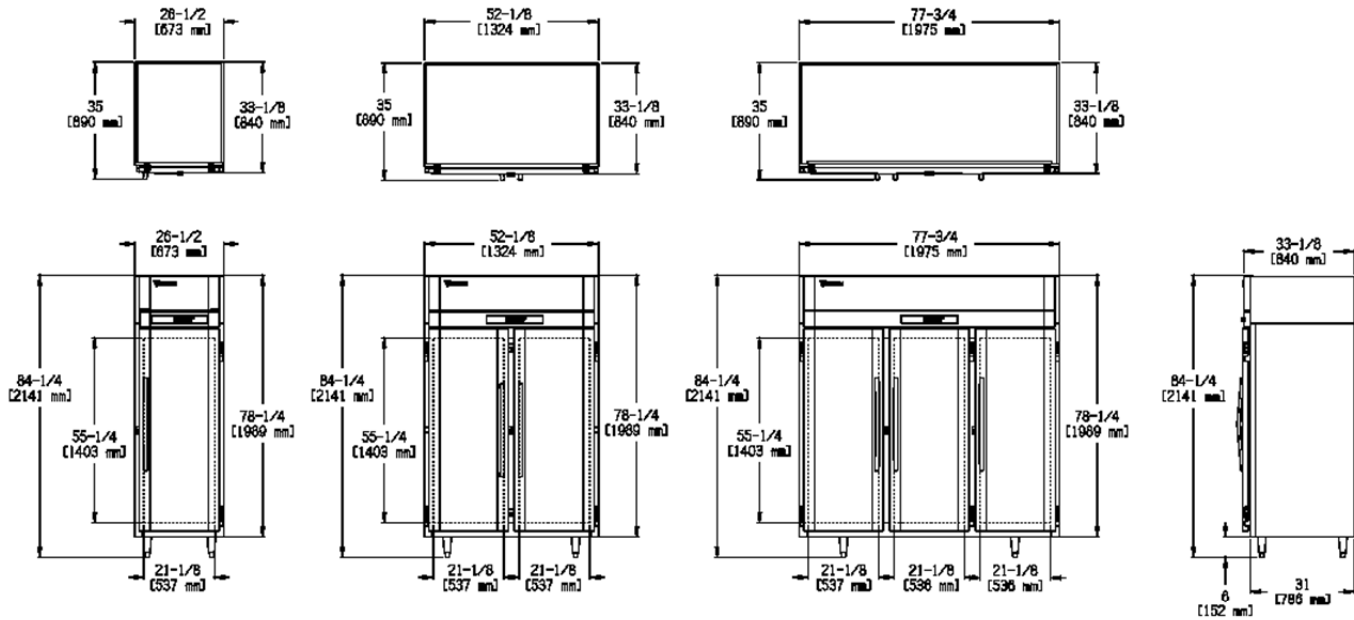

We reserve the right to change specifications and product design without notice. Such revisions do not entitle the buyer to corresponding changes, improvements, additions or replacements for previously purchased equipment. Dimensional tolerances +/- 1/4"; Metric dimensions (MM)

CABINET CONSTRUCTION

The cabinet front and doors are constructed of heavy gauge, polished stainless steel to maintain an attractive appearance after years of heavy use. Polyurethane foam insulation throughout ensures the ultimate in energy efficiency. The front shroud lifts up for easy access when cleaning the condenser unit.

DOOR CONSTRUCTION

The doors are heavy gauge, polished stainless steel with a stainless steel interior liner. Each door is provided with a cylinder lock and ergonomically correct vertical handle. The door hinges are self-closing and have a hold-open feature at 120° which facilitates product loading. Proximity switches energize the recessed interior incandescent lighting when the door is opened. Humidity control wires around the door jamb prevent condensation from forming on the front of the cabinet in high humidity environments. The wires are concealed by a high impact, non-conducting thermal breaker cap.

REFRIGERATION SYSTEM

All components of the high efficiency, air-cooled, self-contained refrigeration system are mounted on top of the cabinet out of the food storage zone providing greater usable storage space. Environmentally friendly R-134a refrigerant is efficiently metered by an expansion valve providing a constant, safe operating temperature and quick "recovery" under the most demanding conditions. The hermetically sealed systems are designed to operate at 38° F. Each cooling coil has plasticized fin coils to resist food acids and dual-speed EC fan motor(s) for greater cooling capacity and efficiency. All condensate water is disposed of automatically by the energy efficient, non-electric condensate evaporator.

INTERIOR STORAGE ARRANGEMENTS

Each cabinet section is provided with three heavy-duty, epoxy coated wire shelves. The shelves are adjustable in one inch increments. A wide door opening allows for the use of a variety of optional pan slide configurations including 18" x 26" and 12" x 20" pans.

V-TEMP™ CONTROL SYSTEM

The easy to use V-TEMP™ Control is standard. This durable, water resistant microprocessor monitors and controls the entire temperature maintenance process. It includes an ON/OFF switch, manual defrost, interior light switch, LED temperature indicator in °C or °F, a HI/LO audio/visual temperature alarm, power supply interruption, door ajar and "clean condenser" alarms. A manager's "lock-out" feature is provided to safeguard pre-determined control settings. A HAACP Event Indicator/Memory feature announces and records up to nine (9) alarm events. Unique to the V-TEMP™ are two standard modes of operation:

- ▶ **SUPERCOOL** - Provides a lower "set-point" refrigeration condition for a set period of time when food has just been loaded into the refrigerator and needs to be quickly brought back down to a safe temperature.
- ▶ **ENERGY SAVING** - The cabinet automatically reverts to the energy saving mode when there are no door openings for four hours.

A **FLEXTMP** mode of operation is available as an option. **FLEXTMP** provides the ability to select a unique temperature from 28° F to 40° F. This optional feature is ideal for seasonal menu changes and items with specific temperature requirements for dairy, meat, fish or poultry.

CHARACTERISTICS

	1 SECTION	2 SECTION	3 SECTION
DIMENSIONAL DATA			
Capacity Net (cubic ft.)	21.5	46.5	70.1
Width, Overall (in.)	26 1/2	52 1/8	77 3/4
Depth, Overall (inc. handles)	35	35	35
Depth, Door(s) Open 90°	56 3/4	56 3/4	56 3/4
Clear Door Width (in.)	21 1/8	21 1/8	21 1/8
Clear Half-Door Height (in.)	25 3/8	25 3/8	25 3/8
Clear Full-Door Height (in.)	55 1/4	55 1/4	55 1/4
Height Overall (inc. 6" legs)	84 1/4	84 1/4	84 1/4
No. Full/Half Doors	1F, 2H	2F, 4H	3F, 6H
No. of Shelves	3	6	9
Shelf Area (square ft.)	15.4	33.2	50.1

ELECTRICAL DATA

Cabinet Voltage	115/60/1	115/60/1	115/60/1
Feed Wires	2	2	2
Condensing Unit Voltage	115/60/1	115/60/1	115/60/1
NEMA Plug	5-15 P	5-15P	5-20P
Total Amperes	9.8	10.7	13.8

REFRIGERATION DATA

Condensing Unit Size	1/3HP	1/3HP	1/2HP
Refrigerant	R-134a	R-134a	R-134a

NOTE: Plug style, voltage and full load amps may vary depending on certain options selected such as optional voltages and compressor upgrades.

REMOTE APPLICATIONS

See form V-RRDS1 for remote refrigeration characteristics by model

CRATED DIMENSIONS & WTS.	HT.	WIDTH	DEPTH	CU. FT.	LBS
ONE SECTION	84 1/2	36	43	75.70	320
TWO SECTION	84 1/2	59 1/4	43	124.59	483
THREE SECTION	84 1/2	86 1/2	43	181.89	625

NOTE: In order to provide peak operating performance the cabinet must have a 2 inch all around clearance and 12 inches above the top of the condensing unit. This ensures an adequate air supply and space for routine maintenance and/or service if required.

****Remote units use R404a refrigerant standard and come with 6" legs.**