



**TRUE FOOD SERVICE EQUIPMENT, INC.**

2001 East Terra Lane • O'Fallon, Missouri 63366-4434 • (636)240-2400  
 Fax (636)272-2408 • Toll Free (800)325-6152 • Intl Fax# (001)636-272-7546  
 Parts Dept. (800)424-TRUE • Parts Dept. Fax# (636)272-9471 • www.truemfg.com

Project Name: \_\_\_\_\_

A/A #

Location: \_\_\_\_\_

Item #: \_\_\_\_\_ Qty: \_\_\_\_\_

SIS #

Model #: \_\_\_\_\_

Model:  
**TUC-48**

**Undercounter:**  
*Solid Door Refrigerator*



Scan code for video

**TUC-48**

- ▶ True's undercounter units are designed with enduring quality that protects your long term investment.
- ▶ Designed using the highest quality materials and components to provide the user with colder product temperatures, lower utility costs, exceptional food safety and the best value in today's food service marketplace.
- ▶ Oversized, environmentally friendly (134A) forced-air refrigeration system holds 33°F to 38°F (.5°C to 3.3°C).
- ▶ All stainless steel front, top and ends. Matching aluminum finished back.
- ▶ Interior - attractive, NSF approved, clear coated aluminum liner with stainless steel floor.
- ▶ Front breathing.
- ▶ Heavy duty PVC coated wire shelves.
- ▶ Foamed-in-place using Ecomate. A high density, polyurethane insulation that has zero ozone depletion potential (ODP) and zero global warming potential (GWP).

**ROUGH-IN DATA**

Specifications subject to change without notice. Chart dimensions rounded up to the nearest 1/8" (millimeters rounded up to next whole number).

Model	Doors	Shelves	Cabinet Dimensions (inches) (mm)			HP	Voltage	Amps	NEMA Config.	Cord Length (total ft.) (total m)	Crated Weight (lbs.) (kg)
			L	D†	H*						
TUC-48	2	4	48 3/8 1229	30 1/8 766	29 3/4 756	1/5 N/A	115/60/1	5.0 4.2	5-15P	7 2.13	280 127

† Depth does not include 1" (26 mm) for rear bumpers.

\* Height does not include 6 1/4" (159 mm) for castors or 6" (153 mm) for optional legs.



APPROVALS:

AVAILABLE AT:

Model:  
**TUC-48**

## Undercounter: Solid Door Refrigerator



### STANDARD FEATURES

#### DESIGN

- True's commitment to using the highest quality materials and oversized refrigeration systems provides the user with colder product temperatures, lower utility costs, exceptional food safety and the best value in today's food service marketplace.

#### REFRIGERATION SYSTEM

- Factory engineered, self-contained, capillary tube system using environmentally friendly (CFC free) 134A refrigerant.
- Oversized, factory balanced refrigeration system with guided airflow to provide uniform product temperatures.
- Extra large evaporator coil balanced with higher horsepower compressor and large condenser; maintains cabinet temperatures of 33°F to 38°F (.5°C to 3.3°C) for the best in food preservation.
- Sealed, cast iron, self-lubricating evaporator fan motor(s) and larger fan blades give True undercounter units a more efficient, low velocity, high volume airflow design. This unique design ensures faster temperature recovery and shorter run times in the busiest of food service environments.
- Condensing unit access in back of cabinet, slides out for easy maintenance.

#### CABINET CONSTRUCTION

- Exterior - stainless steel front, top and ends. Matching aluminum finished back.
- Interior - attractive, NSF approved, clear coated aluminum liner. Stainless steel floor with coved corners.

- Insulation - entire cabinet structure and solid doors are foamed-in-place using Ecomate. A high density, polyurethane insulation that has zero ozone depletion potential (ODP) and zero global warming potential (GWP).
- 5" (127 mm) diameter stem castors - locks provided on front set. 36" (915 mm) work surface height.

#### DOORS

- Stainless steel exterior with white aluminum liner to match cabinet interior.
- Each door fitted with 12" (305 mm) long recessed handle that is foamed-in-place with a sheet metal interlock to ensure permanent attachment.
- Positive seal self-closing doors with 90° stay open feature. Doors swing within cabinet dimensions.
- Magnetic door gaskets of one piece construction, removable without tools for ease of cleaning.

#### SHELVING

- Four (4) adjustable, heavy duty PVC coated wire shelves 21 3/16" L x 16" D (548 mm x 407 mm). Four (4) chrome plated shelf clips included per shelf.
- Shelf support pilasters made of same material as cabinet interior; shelves are adjustable on 1/2" (13 mm) increments.

#### MODEL FEATURES

- Evaporator is epoxy coated to eliminate the potential of corrosion.
- NSF-7 compliant for open food product.

#### ELECTRICAL

- Unit completely pre-wired at factory and ready for final connection to a 115/60/1 phase, 15 amp dedicated outlet. Cord and plug set included.



115/60/1  
NEMA-5-15R

#### OPTIONAL FEATURES/ACCESSORIES

Upcharge and lead times may apply.

- 6" (153 mm) standard legs.
- 6" (153 mm) seismic/flanged legs.
- 2 1/2" (64 mm) diameter castors.
- Barrel locks (factory installed). Requires one per door.
- Single overshelf.
- Double overshelf.
- 30" (762 mm) deep, 1/2" (13 mm) thick, white polyethylene cutting board. Requires "L" brackets.
- 30" (762 mm) deep, 1/2" (13 mm) thick, composite cutting board. Requires "L" brackets.
- Heavy duty, 16 gauge tops.
- Exterior rectangular digital temperature display (factory installed).
- ADA compliant models with 34" (864 mm) work surface height.
- Low profile models with 31 7/8" (810 mm) work surface height.

#### \*CABINET INTERIOR

Beginning in October of 2014, True Manufacturing began the process of changing the standard interior finishes on select products. The interior liners of these units have changed from the traditional NSF-approved white aluminum to an NSF-approved clear coated aluminum that is silver in color. In addition, the traditional white PVC coated shelves have been switched to a gray PVC coating. There are no functional differences created by any of these changes, the difference is only in the appearance. The following product lines are affected by this change: T-Series, TUC, TWT, TSSU, TFP, TPP, TMC, TRCB. A sticker will be placed on the outside packaging so that units with this change can be identified in inventory.

### PI AN VIFW

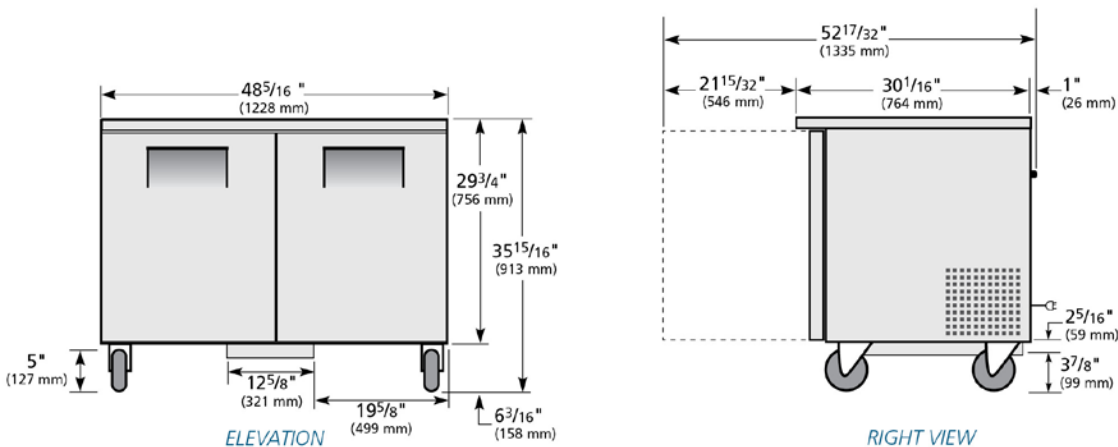

**WARRANTY\***  
Three year warranty on all parts and labor and an additional 2 year warranty on compressor. (U.S.A. only)

METRIC DIMENSIONS ROUNDED UP TO THE NEAREST WHOLE MILLIMETER

SPECIFICATIONS SUBJECT TO CHANGE WITHOUT NOTICE



Model	Elevation	Right	Plan	3D	Back
TUC-48	TFQY02E	TFQY02S	TFQY02P	TFQY023	

### TRUE FOOD SERVICE EQUIPMENT

2001 East Terra Lane • O'Fallon, Missouri 63366-4434 • (636)240-2400 • Fax (636)272-2408 • Toll Free (800)325-6152 • Intl. Fax# (001)636-272-7546 • www.truefmfg.com

\*RESIDENTIAL APPLICATIONS: TRUE assumes no liability for parts or labor coverage for component failure or other damages resulting from installation in non-commercial or residential applications.