

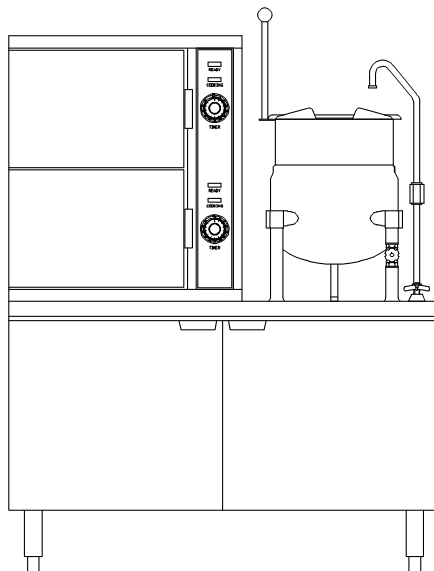

# TWO COMPARTMENT CONVECTION STEAMER WITH KETTLE WITH ELECTRIC BOILER BASE



### SPECIFICATIONS:

Shall be a Southbend model \_\_\_\_\_, convection steamer complete with 6 or 10 gallon kettle on a modular electric steam boiler base, with stainless steel type 304 exterior and #4 finish, deck mounted faucet valve, swing nozzle and integral sink with common drain.

The convection steamer shall have doors with a removable inner liner of stainless steel, full perimeter gasket seal, outer shell of one piece, all welded, stainless steel, positive lock and seal mechanism and a stainless steel drip trough connected to the drain in order to collect condensate when doors are opened. Each cooking chamber shall be constructed of all welded type 316 stainless steel, fully insulated and provided with removable stainless steel pan supports and shall be:

- ECX-2S: 13.875"W x 10.875"H x 19.875"D (352 mm x 276 mm x 504 mm).
- ECX-10S: 13.875"W x 17.375"H x 19.875"D (352 mm x 441 mm x 504 mm).

Steamer controls shall be accessible through a fully removable side panel and each compartment shall include a 60 minute mechanical timer with ready and cooking pilot light and shall interrupt steam flow to the chamber when the compartment door is opened during cooking cycle and shall be reactivated when the door is closed. An audible signal will sound at the end of the cooking cycle.

The cabinet base with electric boiler and controls shall be provided with full perimeter painted angle frame, reinforced kettle and boiler mountings, hinged doors with magnetic latch and 6" (152 mm) stainless steel legs fitted with adjustable bullet feet on the front and adjustable flanged feet on the rear for securing unit to the floor. Boiler controls shall include automatic water level control, pressure gauge, water gauge glass, operating pressure control, safety high-limit pressure control, safety relief valve and cathodic protector. The boiler shall be ASME code stamped and National Board registered.

MODEL	DESCRIPTION	PAN CAPACITY PER COMPARTMENT			
		PAN DEPTH			
		1"	2-1/2"	4"	6"
ECX-2S-6	6 pan steamer with 6 gallon kettle and 36 kW boiler.	6	3	2	1
ECX-2S-10	6 pan steamer with 10 gallon kettle and 36 kW boiler.				
ECX-10S-6	10 pan steamer with 6 gallon kettle and 36 kW boiler.	10	5	3	2
ECX-10S-10	10 pan steamer with 10 gallon kettle and 36 kW boiler.				

### OPERATION SHALL BE BY:

Electrically heated steam boiler operating at 9 -11 psi (62 - 76 kPa) and rated at 36kW. The controls shall be equipped for operation on 115 VAC, single phase 50/60 Hz.

### OPTIONAL ITEMS AT EXTRA COST:

- 42 kW
- 48 kW
- 220 VAC, 1 phase, 60 Hz
- 380 VAC, 3 phase, 60 Hz
- 415 VAC, 3 phase, 60 Hz
- 480 VAC, 3 phase, 60 Hz
- 240/415, 3 phase, 4 wire
- 220/380 VAC, 3 phase, 4 wire
- 208-240 VAC operation (specify voltage)
- CSD-1
- Automatic boiler blow down
- Stainless steel rear panel
- Stainless steel frame
- Split water line
- Correctional package
- Adjustable front flanged feet
- Load compensating timers

### OPTIONAL ITEMS AT EXTRA COST:

- Spray and rinse assembly
- Steam take-off kit
- De-liming kit (DPA-1) not available with CSD-1
- Water in "Y" strainer



Job # Item #

Models:  ECX-2S-6

ECX-2S-10

ECX-10S-6

ECX-10S-10

MODEL	SHIPPING WEIGHT
ECX-2S-6	980 lbs. [445 kg.]
ECX-10S-6	1000 lbs. [454 kg.]
ECX-2S-10	1030 lbs. [467 kg.]
ECX-10S-10	1050 lbs. [476 kg.]

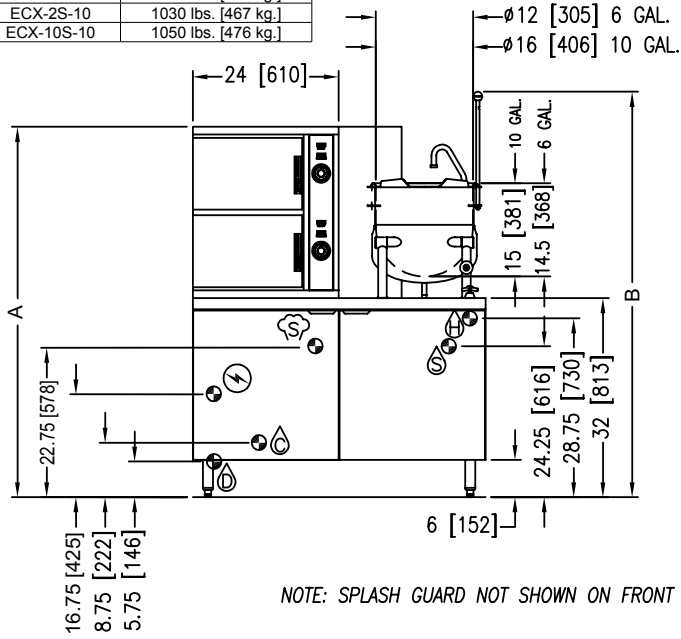

NOTE: SPLASH GUARD NOT SHOWN ON FRONT VIEW.



**REAR FLANGED FOOT DETAIL**  
 2 EQUALLY SPACED  
 Ø7/16" [11mm] HOLES  
 ON 2.5" [63mm] B.C.

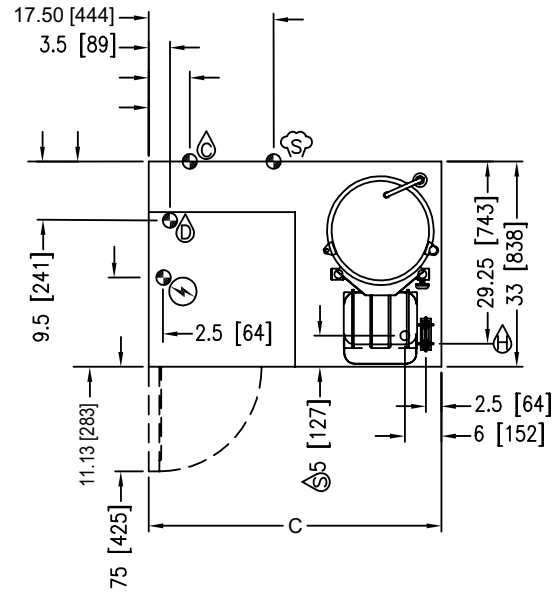

**SERVICE CONNECTIONS**

- ⚡ – ELECTRICAL CONNECTION: 1/2" (13 mm) conduit connection to controls. Rating to be specified on data plate.
- ⊕ – STEAM TAKE-OFF CONNECTION: 3/4" (19 mm) IPS optional to operate adjacent equipment.
- ⊖ – COLD WATER: 3/8" (10 mm) O.D. tubing at 25-50 PSI (170-345 kPa).
- ⊕ – HOT WATER: 3/8" (10 mm) O.D. tubing at 25-50 PSI (170-345 kPa).
- ⊖ – DRAIN: 2" (51 mm) IPS piped to open floor drain. No solid connection.
- ⊕ – SINK DRAIN: 1-1/8" (29 mm) O.D. tubing.

MODEL	A	B	C
ECX-2S-6	59.5 [1511]	66.13 [1680]	44 [1118]
ECX-10S-6	72.5 [1842]		44 [1118]
ECX-2S-10	59.5 [1511]	65.13 [1654]	48 [1219]
ECX-10S-10	72.5 [1842]		48 [1219]

**ELECTRICAL CHARACTERISTICS**

MODEL	AVAILABLE kW	
	STANDARD	OPTIONAL
ECX-2S-6	36	42, 48
ECX-10S-6		
ECX-2S-6		
ECX-10S-10		

kW	PHASE	AMPS PER LINE					
		208V	220V	240V	380V	415V	480V
36	3	99.9	94.5	86.6	54.7	50.1	43.3
42	3	116.6	110.2	101.0	63.8	58.4	50.5
48	3	N/A	N/A	115.5	72.9	66.8	57.8

**WATER QUALITY STATEMENT**

Water quality is the major factor affecting the performance of your appliance. If you are unsure of water quality, consult a local water treatment specialist and have the water analyzed. Your water supply must be within these general guidelines:

- Total dissolved solids .....Less than 60 PPM
- Total alkalinity .....Less than 20 PPM
- Silica.....Less than 13 PPM
- Chlorine .....Less than 30 PPM
- pH Factor .....7.0 - 8.5

Water which fails to meet these standards should be treated by installation of water conditioner.

**FAILURE OR MALFUNCTION OF THIS APPLIANCE DUE TO POOR WATER QUALITY IS NOT COVERED UNDER WARRANTY. CONTACT SOUTHBEND FOR WATER QUALITY SOLUTIONS.**

**INTENDED FOR COMMERCIAL USE ONLY.  
 NOT FOR HOUSEHOLD USE.**



1100 Old Honeycutt Road, Fuquay-Varina, NC 27526  
 (919) 762-1000 www.southbendnc.com