

**PRODIGY**  
PLUS

**Eclipse™**

# EH330 - 1400lb Cube Ice Machine

Prodigy Plus® Eclipse® Remote Cooled Modular Cube Ice Machine

## The world's smartest cuber.

As the world's only self-monitoring cuber, the new Scotsman Prodigy Plus® cube ice machines make it easier than ever to maintain your equipment and save money. Whether it's the advanced ice level control or an optional feature board for quick diagnostics, this is ice-making re-imagined. And with intuitive technology like AutoAlert™ indicator lights, a reduced operational footprint and easy-access service from the front panel, Prodigy Plus® cubers are simply the smartest, most reliable way to create fresh-tasting ice — every time.



## The Prodigy Plus® difference.

- AutoAlert™ indicator lights for better visibility
- Operational footprint among the industry's smallest
- Industry-exclusive QR code instantly connects users to service information and warranty history
- One-touch cleaning reduces labor costs and saves time
- Front-located air filter for more efficient operation
- Self-aligning front panel for easy access to key components
- Patented WaterSense purge control automatically reduces scale buildup
- Patented Harvest Assist efficiently moves cube ice to the bin
- Smart-Board™ advanced feature module available for additional diagnostic capabilities
- Optional Vari-Smart™ ice level control allows operators to customize ice levels
- Antimicrobial protection guards internal surfaces between cleanings
- A full range of water- and energy-saving features



ECC1200 remote condensing unit

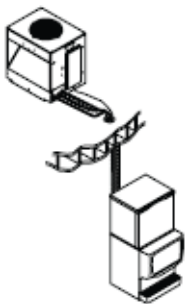

Eclipse System connected to single remote CP & condenser



## 24 Hour Volume Production

EH330 1400lb

70°F/21°C	Air	90°F/32°C
50°F/10°C	Water	70°F/21°C
1411/641		1200/545
lb/kg		lb/kg



## Dispenser Options

Model Number*	Dimensions W" x D" x H"	Application Capacity lb/kg	Finish	Ship Weight lb/kg
ED200	30 x 30 x 35	200/91	Stainless Steel	200/91
ED250	30 x 30 x 40	250/114	Stainless Steel	300/136
IDC255	30 x 30 x 40	255/116	Stainless Steel	350/159

\* Contact Scotsman for bin top requirements.



## Cube Ice

Common ice form, ideal for mixed drinks.



Small Cube  
7/8" x 7/8" x 3/8"  
(2.22 x 2.22 x .95 cm)



## Certification



## Warranty

- 3 years parts and labor on all components.
- 5 years parts and labor on the evaporator.
- 5 years parts on the compressor and condenser.

Warranty valid in North, South & Central America. Contact factory for warranty in other regions.

**Scotsman**  
ICE THE WORLD DEMANDS

• 775 Corporate Woods Parkway, Vernon Hills, IL 60061 •

• 1-800-SCOTSMAN • Fax: 847-913-9844 • www.scotsman-ice.com • customer.relations@scotsman-ice.com •

EH330 - 1400lb Cube Ice Machine

# EH330 - 1400lb Cube Ice Machine

Prodigy Plus® Eclipse® Remote Cooled Modular Cube Ice Machine

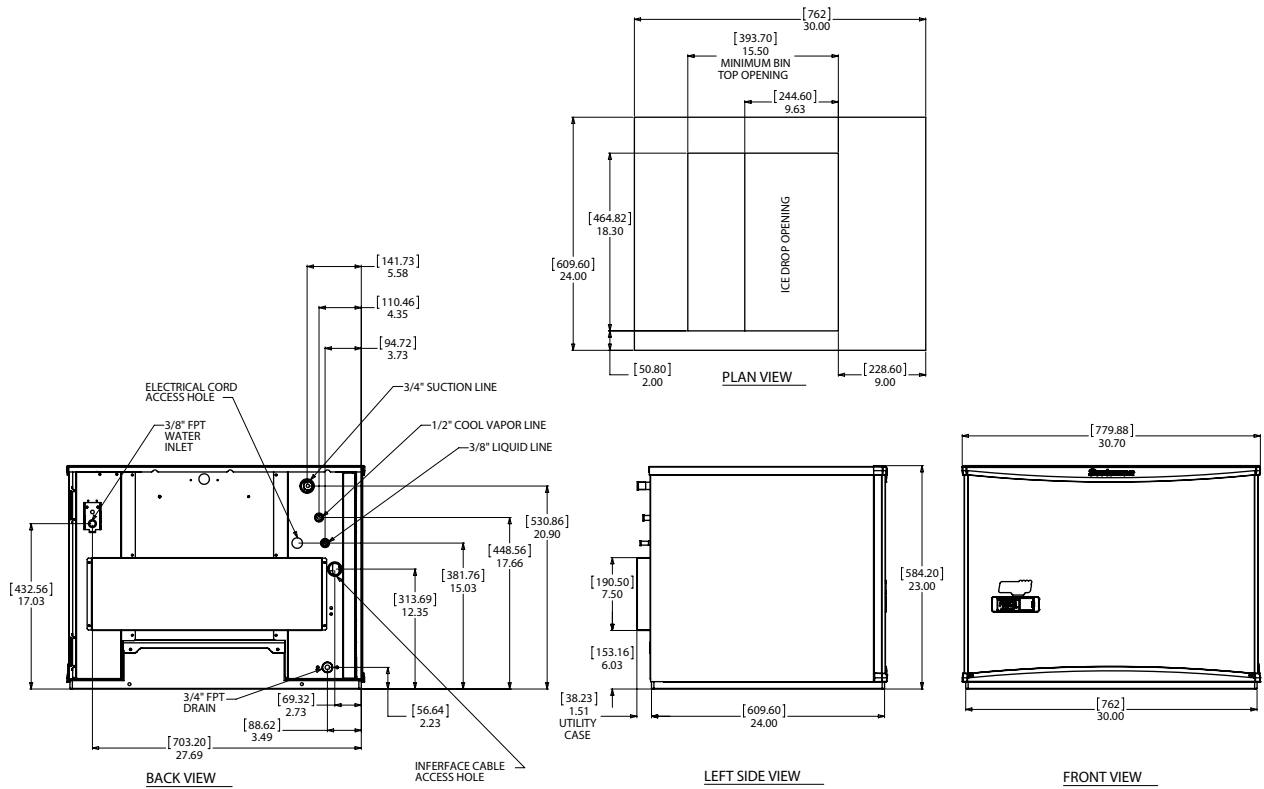

## Specifications

Model Number	Condenser Unit	Basic Electrical Volts/Hz/Phase	Max. Fuse Size or HACR Circuit Breaker (amps)	Circuit Wires	Min. Circuit Ampacity	Energy Consumption 90°F(32°C)/70°F(21°C)	Water Usage Gallons/100 lb (liters/45.4 kg)		Energy Star®
							Potable 90°F(32°C)/70°F(21°C)	Condenser 90°F(32°C)/70°F(21°C)	
EH330SL-1B	-	115/60/1	15	2	Cord	-	-	-	-
-	ECC1200-32A	208-230/60/1	30	2	17.8	5.0	18.0/68.1	-	-



## All Models

**Dimensions (W x D x H):**

EH330 Unit: 30" x 24" x 23"  
(76.2 x 61.0 x 58.4 cm)

Shipping Carton: 33.5" x 27.5" x 28"  
(85.1 x 70.0 x 71.1 cm)

Condenser Unit: 30" x 18" x 35"  
(76.2 x 45.7 x 88.9 cm)

Shipping Carton: 42" x 34" x 45"  
(83.8 x 53.3 x 96.5 cm)

**Shipping Weight:** EH330xL 175 lb / 80 kg  
ECC1200 310 lb / 141 kg

**BTUs per hour:** 19,000 (EH330)

Refrigerant: R-404A



## Accessories

Model Number	Description
KVS	Vari-Smart™ Ice Level Control - Program ice bin levels to match ice needs.
KSBU	Smart-Board™ Advanced Control - Use additional operational data for fast diagnosis.
KSBU-N	Smart-Board™ Advanced Control with Network - Network capable.
3BRTE20-EH	Line set, 20 ft. Refrigerant and brazing required
3BRTE35-EH	Line set, 35 ft. Refrigerant and brazing required
3BRTE50-EH	Line set, 50 ft. Refrigerant and brazing required
3BRTE75-EH	Line set, 75 ft. Refrigerant and brazing required

Scotsman recommends all ice machines have water filtration. See Scotsman water filter specification sheet for details.



## Operating Requirements

	Minimum	Maximum
Air Temperatures	50°F (10°C)	100°F (38°C)
Water Temperatures	40°F (4.4°C)	100°F (38°C)
Remote Cond. Temps	-20°F (-29°C)	120°F (49°C)
Water Pressures	20 PSIG (1.4 bar)	80 PSIG (5.5 bar)
Electrical Voltage	-5%	+10%



Specifications and design are subject to change without notice.