



1415 Countertop Electric Deck Oven



OPTIONS AND ACCESSORIES (AT ADDITIONAL CHARGE)

- Stacking kit
- 4" legs with adjustable sanitary feet

Project _____

Item No. _____

Quantity _____

Ovens consist of basic sections and are a complete and separate unit capable of operating alone or in combination.

All data is shown per oven section, unless otherwise indicated.

Refer to operator manual specification chart for listed model names.

EXTERIOR CONSTRUCTION

- Stainless steel front, top and sides
- Aluminized steel back and bottom
- Drop down type doors
- 1" high-temperature mineral fiber sheet insulation on top, back, sides and bottom

INTERIOR CONSTRUCTION

- 20" x 20" x 9" (508mm x 508mm x 229mm) oven compartment interior
- Aluminized steel baking compartment liner
- Cordierite oven deck
- No. 16 gauge aluminized steel heater shelf assemblies

OPERATION

- 3 tubular type heaters (208 or 240 VAC) 3750 total watts
- Thermostat actuated contactor heater control
- Solid state digital display control with temperature range of 150° to 500°F (66° to 260°C) and a maximum 12 hour timer with audible alarm

STANDARD FEATURES

- Fahrenheit dial 200° to 500°F
- Two year parts and one year labor warranty
- Five year limited oven door warranty*

** For all international markets, contact your local distributor.*

1415 COUNTERTOP DECK



Intertek

BLODGETT OVEN COMPANY

www.blodgett.com • 44 Lakeside Avenue, Burlington, VT 05401 • Phone: (802) 658-6600 • Fax: (802) 864-0183



MODEL 1415

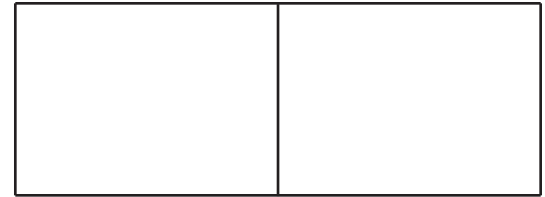

APPROVAL/STAMP

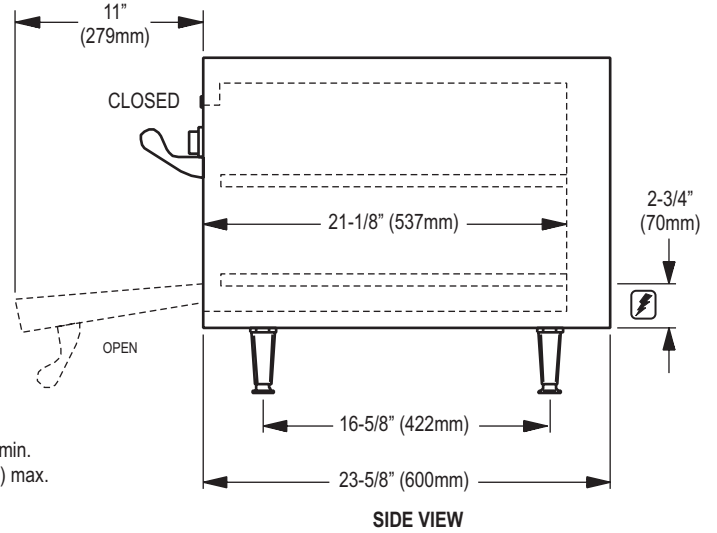
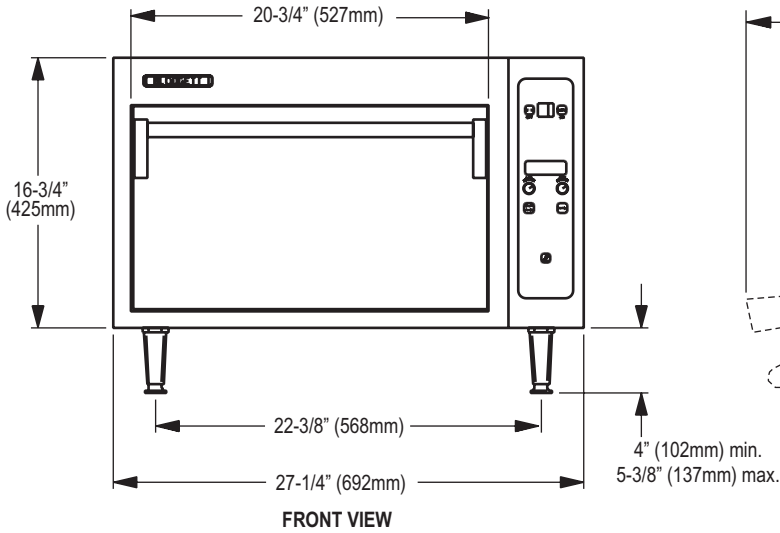

DIMENSIONS:

	Single	Double
Number of sections:	1	2
Number of controls:	1	2
Number of compartments:	1	2
Size of compartments:	20" x 20" x 9" (508mm x 508mm x 229mm)	
Clearance below oven:	4" (102mm) minimum	
Counter space:	27-3/8" x 23-11/16" (695mm x 602mm)	
Minimum entry clearance:	23" (548mm)	

MINIMUM ENTRY CLEARANCE:

Uncrated	17" (431 mm)
Crated	26" (660 mm)

SHIPPING INFORMATION:

Approx. Weight:

Single:	253 lbs. (115 kg)
Double:	506 lbs. (229 kg)

Crate size: 33" x 36" x 35"
(838 mm x 914 mm x 889 mm)

POWER SUPPLY:

1400 Series (three heaters)

V.A.C.	Hz	Phase	kW	Amperes (L1-L2-L3)
208	60	1	3.75	18-0-18
208	60	3	3.75	11-11-11
220-240	60	1	3.75	17-0-17
220-240	60	3	3.75	10-10-10

NOTE: The company reserves the right to make substitutions of components without prior notice

NOTE: The company reserves the right to make substitutions of components without prior notice

BLODGETT OVEN COMPANY

www.blodgett.com • 44 Lakeside Avenue, Burlington, VT 05401 • Phone: (802) 658-6600 • Fax: (802) 864-0183