



BEVERAGE-AIR

3779 Champion Blvd., Winston-Salem, NC 27105
1-888-845-9800 Fax# 1-336-245-6453
<http://www.Beverage-Air.com>

CUSTOMER'S CHOICE FOR A HOT LOCATION
Tested & Certified to Ambient Class of 100°F

3 Year Parts/Labor Warranty Additional 2 Year Compressor Warranty

MARKETMAX DUAL TEMPERATURE GLASS DOOR MERCHANDISER

Double section, DUAL TEMPERATURE glass door merchandiser with lighted sign panel used for merchandising and storage of product.

CABINET CONSTRUCTION

Heavy duty construction includes white coated steel interior walls. White or black exterior finishes are heavy-duty steel with a baked on durable coating. Stainless steel interior option available, which makes unit certified for open food products.

Foamed-in-place CFC and HCFC-free polyurethane insulation.
Modern, one-piece grille is easily removed for cleaning and servicing.

Freezer section has heated triple pane glass. Inside and outside panes are tempered for added safety. Anti-microbial door handles are standard. Doors provide automatic hold-open feature.

Lighted sign panel standard.

SHELVING

Five (5) heavy duty epoxy coated wire shelves per section standard.
Four (4) shelf clips included per shelf (field installed).
Shelves are adjustable in ½" increments.

ELECTRONIC CONTROL

Electronic thermostat with manual defrost (*freezer*) button provides a digital display of cabinet temperatures, which includes status indicators and key pad for any necessary temperature adjustments.

REFRIGERATION

Self-contained bottom mount refrigeration system. Expansion valve refrigerant control on freezer section provides quick temperature pull down and reduces compressor run time—meaning reduced energy consumption. Includes automatic condensate disposal. Refrigerators utilize ozone friendly R134a refrigerant. Freezer section utilizes ozone friendly R404A refrigerant and its defrost system is fully automatic, time-initiated and temperature terminated operation.

Freezer section product temperatures from -10°F to -15°F.
Refrigerator section product temperatures from 36°F to 38°F.

ELECTRICAL

Interior fluorescent lighting enhances product illumination.
Optional LED lighting provides hidden light source for increased product visibility. LED bulbs last up to 10 times longer compared to fluorescent bulbs and renders additional energy savings due to reduced wattage load on compressor.

Refrigerator section wired at factory and ready for connection to a 115/60/1 phase, 15 amp dedicated outlet. Freezer section wired at factory and ready for connection to a 115/60/1 phase, 20 amp dedicated outlet. 8' long cord and plug set included.

Item No. _____
Quantity _____

**HINGED GLASS DOOR
MARKETMAX®
DUAL-TEMP
MERCHANDISER SERIES**
MMRF49 Refrigerator/Freezer
Double Door

MODELS:
MMRF49-1-B
MMRF49-1-W
MMRF49-1-B-LED
MMRF49-1-W-LED



MMRF49-1-W
(SHOWN IN WHITE EXTERIOR)

SPECIAL FEATURES

- Anti-microbial door handles
- Electronic control with digital display
- Lighted sign panel
- Optional LED lighting
- **Flexible door configurations:** freezer/refrigerator or refrigerator/freezer (*see page 2*)
- **Available options:** S/S Exterior, Black Interior, Wine Racks, Black Shelves, Spring Feed Dividers, Casters, Audible Alarm, Optional Headers in Black, White or Stainless, Optional Customized Graphics



115/60/1
NEMA-5-15P



115/60/1
NEMA-5-20P
Freezer

ELECTRICAL CONNECTION

Units pre-wired at factory and include 8' long cord and plug set.

Available From:



*Note: Not all markings may apply to all model variations.

Model Specified _____	Store# _____
Location _____	Quantity _____



BEVERAGE-AIR

PLAN VIEWS

MarketMax Dual-Temp. Merchandisers

Model: MMRF49-1-B, MMRF49-1-W, MMRF49-1-B-LED, MMRF49-1-W-LED

Note: Other door configurations available. Contact factory.

MODEL	MMRF49
EXTERNAL DIMENSIONAL DATA	
Length Overall (inches)	52"
Length Overall (mm)	1321
Depth Overall (inches) - includes handle	33 3/4"
Depth Overall (mm) - includes handle	857
Height Overall— (inches)	78"
Height Overall— (mm)	1981
Number of doors	2
Depth with Door Open 90 °	60"
INTERNAL DIMENSIONAL DATA	
NET Capacity (cubic ft.)	49
NET Capacity (Liters)	1388
Internal Length Overall (inches)	49"
Internal Length Overall (mm)	1245
Internal Depth Overall (inches)	28 1/2"
Internal Depth Overall (mm)	724
Internal Height Overall—(inches)	61 3/4"
Internal Height Overall—(mm)	1569
ELECTRICAL DATA	
Full Load Amperes 115/60/1 (Freezer section)	10.9 A
Full Load Amperes 115/60/1 (Refrigerator section)	5.8 A
REFRIGERATION DATA	
Horsepower (Freezer section)	1/2
Horsepower (Refrigerator section)	1/3
WEIGHT DATA	
Gross Weight (Crated lbs)	696
Gross Weight (Crated kg)	315

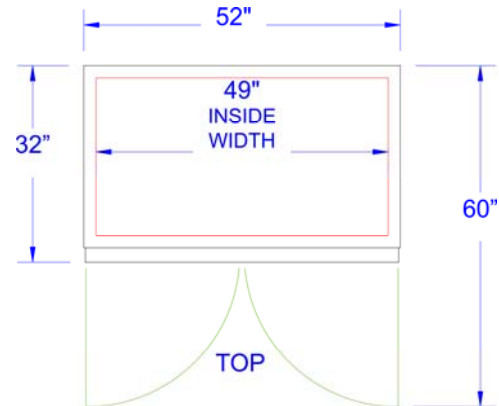
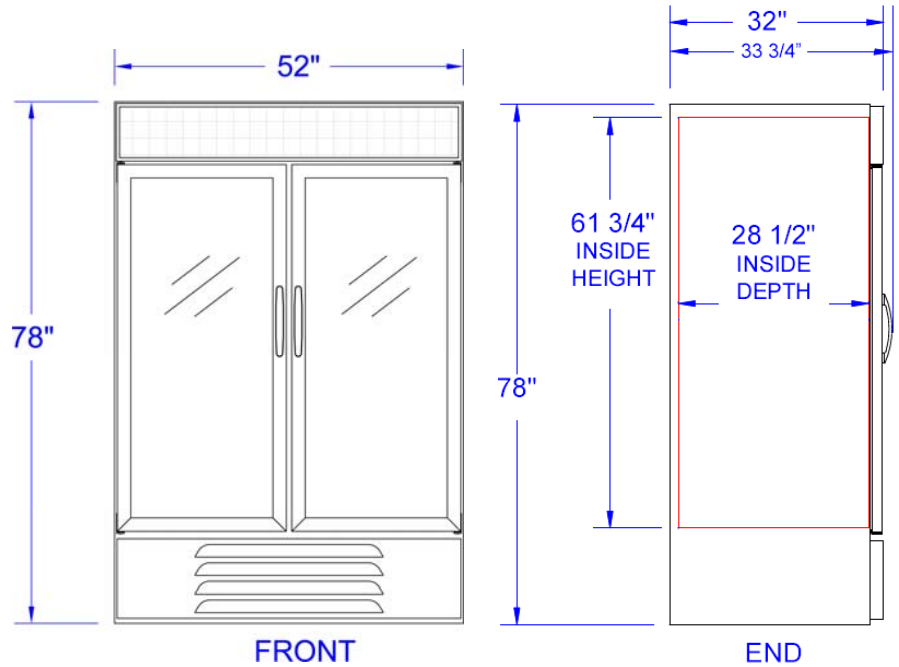

Note: Not all markings may apply to all model variations.

DOOR CONFIGURATIONS (CHOOSE 1)

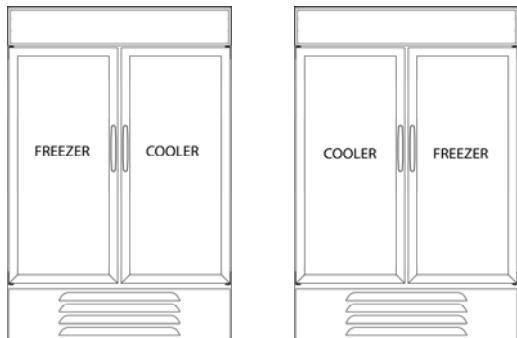

BEVERAGE-AIR® CORPORATION

3779 Champion Blvd. • Winston-Salem, NC 27105 USA • (336) 245-6400 • Fax (336) 245-6453 • (888) 845-9800 • www.beverage-air.com

Specifications are subject to change without prior notice. 03/15