



HEAVY DUTY PORTABLE BAR WITH STAINLESS STEEL INTERIOR

Item #: _____ Qty #: _____
 Model #: _____
 Project #: _____

FEATURES:

All Stainless Steel Interior
 19" x 13-1/2" x 11" insulated ice bin. Complete with drain & shut-off valve
 Full perimeter bumpers

COLD PLATE MODELS:

Two 19" x 13-1/2" x 11" insulated ice bin with 7 Circuit Post Mix Cold Plate. Includes Stainless Steel bottom, complete with drain & shut-off valve
 4 - 6" Heavy Duty Swivel Casters, 2 with brakes

MATERIAL:

TOP & FRONT: Mica Laminate, black finish
UNIT: Stainless Steel work top, back, sides & bottom
WORK AREA: Stainless Steel
CASTERS: Rubber
SPEED RAILS: Stainless Steel

ALL STAINLESS STEEL INTERIOR! Upgrade for Stainless Steel Front Available.

DESIGNED FOR HEAVY-DUTY USE

**Custom Colors Available!
(Exterior Only. See below for details)**



AMS-5B Shown



AMD-6B Shown

| Model # | Size L x W x H | Storage Cabinet Dim. | Bar Top Width | Weight | Cubic Feet |
|--|-------------------|-------------------------|------------------|--------|---------------|
| AMS-5B | 61" x 23" x 47" | 58" x 21" x 18.5" | 12" | 315 | 50 |
| AMS-6B | 74" x 23" x 47" | 23.5" x 21" x 27.5" | 12" | 350 | 60 |
| 7 Circuit Post Mix Cold Plate Units | | | | | |
| AMS-5B-7 | 61" x 23" x 47" | 58" x 21" x 18.5" | 12" | 370 | 50 |
| AMS-6B-7 | 74" x 23" x 47" | 23.5" x 21" x 27.5" | 12" | 420 | 60 |
| UNITS WITH STAINLESS STEEL DOORS | | | | | |
| AMD-5B | 61" x 23" x 47" | 58" x 21" x 18.5" | 12" | 315 | 50 |
| AMD-6B* | 74" x 23" x 47" | 23.5" x 21" x 27.5" | 12" | 350 | 60 |
| 7 Circuit Post Mix Cold Plate Units | | | | | |
| AMD-5B-7 | 61" x 23" x 47" | 58" x 21" x 18.5" | 12" | 370 | 50 |
| AMD-6B-7* | 74" x 23" x 47" | 23.5" x 21" x 27.5" | 12" | 420 | 60 |

*Units Include Center Stainless Steel Panel For Extra Support

Available Accessories

Custom Mica Colors - **Model SU-81**
 (Custom colors include exterior finishes only (Bar front, doors-if applicable and bar top. All interiors are standard black finish)



Customer Service Available To Assist You 1-800-645-3166 8:30 am - 8:00 pm E.S.T.

For Orders & Customer Service:
 Email: customer@advancetabco.com or Fax: 631-242-6900

For Smart Fabrication™ Quotes:
 Email: smartfab@advancetabco.com or Fax: 631-586-2933

DIMENSIONS and SPECIFICATIONS

TOL ± .125"

ALL DIMENSIONS ARE TYPICAL

AMS SERIES

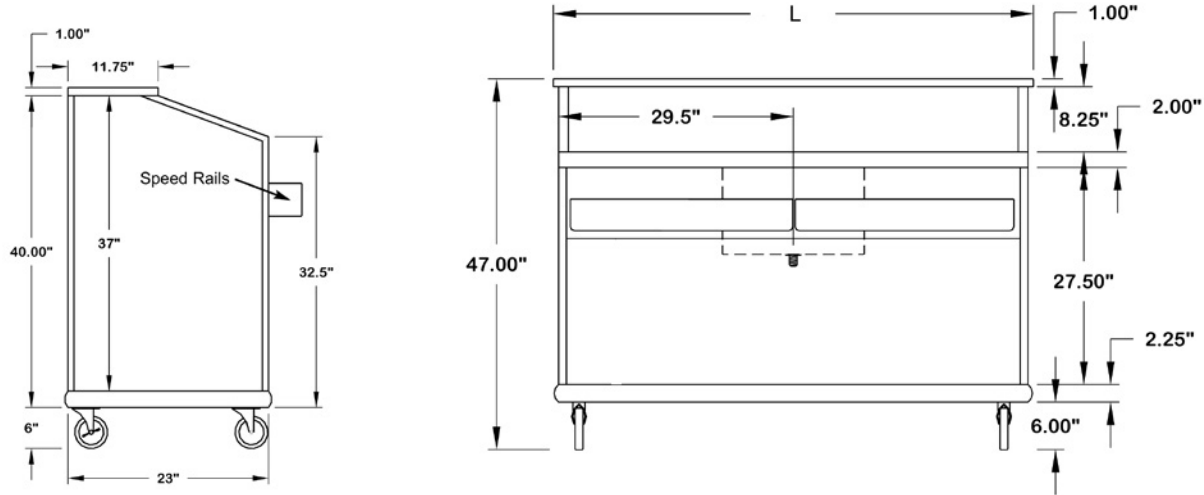

AMD SERIES

