



PHB495 AIR-SCREEN TRAYLINE REFRIGERATOR

CARTER-HOFFMANN
11
MOBILE REFRIGERATORS

SPECIFICATIONS

Printed in U.S.A. G20 0109
Carter-Hoffmann is a trademark
of Carter-Hoffmann, LLC

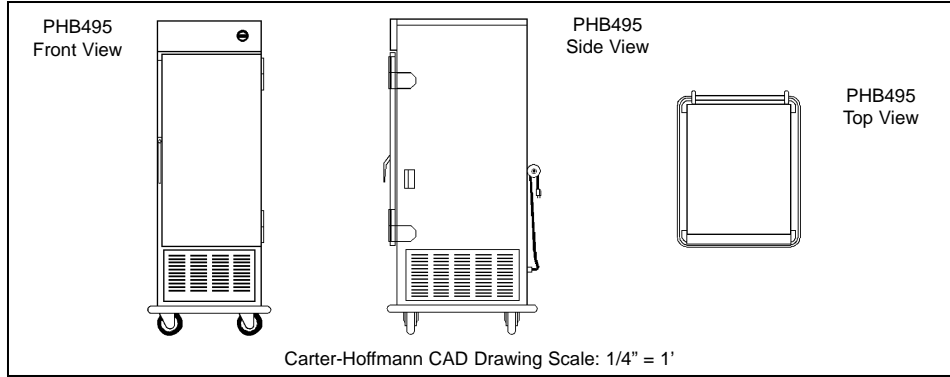

Model Number	Pan/Tray Capacity		Slide Pairs Standard	Inside Working Height		Overall Dimensions			Caster Diameter		Shipping Weight				
	14"x 18"	18"x26"		in	mm	Height in mm	Depth in mm	Width in mm	in	mm	lbs	kgs			
PHB495	30	15	15	45 ³ / ₄	1162	78	1981	38 ¹ / ₂	978	31 ¹ / ₂	800	6	152	541	226

CONSTRUCTION... Completely welded cabinet construction with outer cabinet formed and welded to base. All seams turned in to eliminate raw edges.

CABINET MATERIAL... All stainless steel construction; 20 gauge polished exterior and 24 gauge interior.

BASE FRAME... 12 gauge stainless steel full depth caster bolsters with 1" x 1" 14 gauge stainless steel channels welded to bolsters.

CASTERS... 6" diameter, all swivel, polyurethane tread. Sealed roller bearing swivel. Zerk grease fittings. Plate mounted and bolted to base in offset, wheel-ahead pattern. Two casters fitted with brakes.

BUMPER... Non-marking gray vinyl bumper set in heavy-duty 3/16" thick extruded aluminum frame with reinforced corner cutouts.

INSULATION... 1 1/2" thick high density continuous wrap-around type fiberglass insulation.

STYLING... All stainless steel with glass door.

DOOR... Tempered glass door set in extruded aluminum frame. Positive action door hold up device keeps door open and in place for easy loading and unloading. Field reversible.

HINGES... Welded on, stainless steel 12 gauge butt type hinges with 3/8" fixed pin. 270 degree door swing. Field-reversible.

PUSH HANDLE... 1" diameter stainless steel tubular push handle bolted to rear of cabinet. Extends full width of cabinet. Equipped with donut bumpers on each end.

LATCH... Heavy-duty edgemount latch with magnetic catch.

THERMOMETER... Digital type thermometer set flush with control panel. Remote sensing bulb.

TRAY RACK ASSEMBLIES... Heavy-duty 18 gauge stainless steel angle slides fixed at 3" spacing. "No-tip" feature to facilitate partial pull-out of pans for easy access to contents. Partial pull-out of a pan will not "break" air screen.

ON/OFF SWITCH... Toggle style with guard.

REFRIGERATION SYSTEM... Self-contained evaporator coil and blower refrigeration system. Components include 1/2 h.p. air cooled high torque condensing unit, dual fan, horizontal air screen, 1/2 ton expansion valve, filter/dehydrator and large capacity electrical condensate evaporator. Expanded thermostat differential eliminates need for defrost cycle. Refrigerant charge of approx. 1 lb. CFC-free R134a.

ELECTRICAL CHARACTERISTICS... Operates on 120 volts, 60 cycle, single phase, 11.0 running amps. Ten foot 3-wire rubber cord with 3 prong grounding plug. NEMA 5-20P.

PERFORMANCE... Capable of cooling cabinet to 35°F to 40°F. Approximate pull down time to 40°F - 30 minutes. Air curtain capable of maintaining 40°-45°F internal air temperature for two hours with door open.

ACCESSORIES/OPTIONS...

- Rack hold down device
- Locking door latches
- Menu card holder
- Solid stainless steel door
- Dutch doors; glass or stainless steel

Specifications subject to change through product improvement & innovation.



CARTER-HOFFMANN
1551 McCormick Ave., Mundelein, IL 60060
(847) 362-5500 • (800) 323-9793 • Fax (847) 367-8981
www.carter-hoffmann.com

FEATURES & BENEFITS

PHB495

AIR SCREEN TRAYLINE REFRIGERATOR

Since 1947, foodservice equipment that delivers!

**COMPLETELY WELDED
TURNED-IN SEAM
CONSTRUCTION...**

All stainless steel construction. Adds rigidity to entire cabinet for maximum durability and reliable performance, and eliminates raw edges for easy cleaning and safety.

**HIGH EFFICIENCY
REFRIGERATION SYSTEM
WITH ENVIRONMENTALLY
SAFE COOLANT...**

Highly efficient refrigeration system provides faster pull down and recovery times. Increased thermostat differential allows compressor to cycle more efficiently and eliminates need for defrost cycle.

**POLYURETHANE TREAD
CASTERS WITH SEALED
ROLLER BEARING...**

Long lasting, easy rolling for maximum load and minimum maintenance.

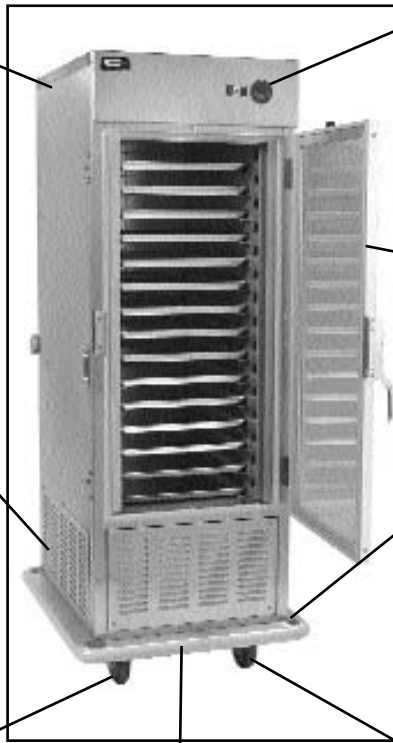

**DIGITAL READ-OUT
THERMOMETER...**

For fast, accurate temperature readings with no calibration.

**270 DEGREE DOOR SWING
WITH DOOR HOLD OPEN
DEVICE...**

Door swings out of the way and is held securely in place for easy loading and unloading. Field-reversible hinges.

**HEAVY-DUTY STAINLESS
STEEL BASE FRAME...**

12 gauge caster boosters with tubular perimeter frame to withstand heavy loads and harsh transport conditions.

**NON-MARKING BUMPER SET
IN HEAVY-DUTY 3/16" THICK
EXTRUDED ALUMINUM
FRAME...**

Protects doorways, walls and cart from damage.

**OFFSET "WHEEL AHEAD"
PATTERN...**

Only one wheel can pass over uneven surfaces at a time for easy handling and steering.

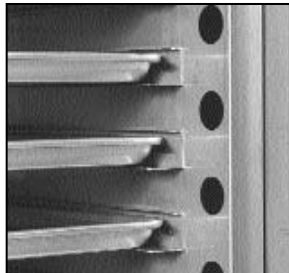

**"NO TIP" TRAY
SLIDES...**

Trays cannot tip - even when pulled out half way. Enable easier access to contents of cabinet without affecting air screen.

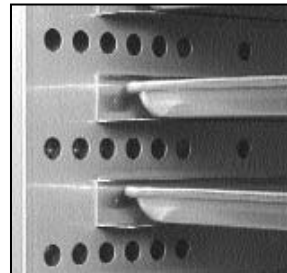

**DUAL FAN HORIZONTAL
AIR SCREEN...**

Designed to maintain lower interior cabinet temperature. Pan pulled out part way will not affect air screen.

1551 McCormick Avenue, Mundelein, Illinois 60060
Tel. (847)362-5500 • (800)323-9793 • Fax (847)367-8981
www.carter-hoffmann.com

