

Item No.

Anets Premier GoldenFry Series High Performance Fryer with the Convenience of 2 Separate Frypots

All of the features and benefits of our high efficiency MX-14 series gas fryer with the added convenience of separate frypots and controls. Now two different products can be prepared at the same time. And during the slower periods you can use only one frypot and save energy. Each stainless steel frypot includes Anets copper flashed heat exchangers, with separate burner systems to maximize heat transfer and produce quick recovery. Unit is available with automatic basket lifts with 15 minute timers (Model MX-14-2AA)

STANDARD FEATURES

- Independent temperature controls cook two different products at two different temperatures at the same time
- Copper-flashed heat exchangers transfer heat directly into frypot for maximum efficiency
- Open vat design with sloped sides forces food particles to fall into the easily accessible cold zone
- Fully insulated cabinet keeps the kitchen cool
- Stainless steel basket hanger lifts off for easy cleaning
- Separate front 1-1/4" NPT drains for each frypot



Model MX14-2E shown with optional casters

A N E T S
GoldenFry™



ANETS

Anetsberger Brothers, Inc. ■ Dependable Foodservice Equipment
180 North Anets Drive ■ Northbrook, Illinois 60062-5452
1-800-837-2638 ■ Fax 847-272-1943 ■ www.anets.us



SPECIFICATIONS

- Model
- Certification
- Gas Input
- Gas Pressure
- Gas Connection
- Electrical Requirements

- Thermostat
- Temperature Range
- Burners
- Hi-limit

- Safety Pilot
- Spark Ignitor
- Frypots
- Cabinet

- Shortening Capacity

MX14-2E, Basic
 MX14-2AA, Fully automatic dual basket lifts with individual 15 minute timers
 UL, NSF
 110,000 BTU/hr (55,000 per side)
 NG 3.5" WC, LP 10" WC
 3/4" NPT
 MX14-2E, 120V, 60Hz, 1Ph, 2 Amps
 MX14-2AA, 120V, 60Hz, 1Ph, 7 Amps
 Electric snap action type for each side
 200° to 375°F (93°-191°C)
 Atmospheric pre-mix
 Safety control turns off main gas supply at 440°F (227°C) for each side
 100% gas shut off valve for each side
 Piezo-electric for each side
 Stainless steel
 Door, stainless steel
 Sides, painted
 Backsplash, stainless steel
 17-25 lbs each side

STANDARD ACCESSORIES

- 2 Twin Nickel plated baskets
- Rack type basket support, each side
- Clean out rod
- 6" adjustable legs
- Drain pipe extension

OPTIONS AND ACCESSORIES

- Stainless steel sides
- Built-in filter systems, Filtronic II
- Casters
- Fryer cover
- Drain table
- Front drain tray
- Solid State thermostat
- Electronic Ignition
- Can bank units at no additional charge
- Fri-Tronic™ multi-product computers with shortening melter, boil out mode and digital timers
- Sediment tray
- Common gas manifold
- Fryer cleaning brush

Specifications subject to change without notice.
 SS# 115 2/07
 Printed in the U.S.A.

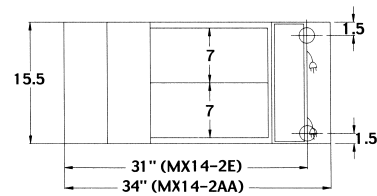

Top View

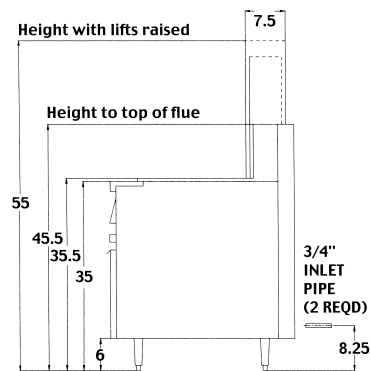

Side View

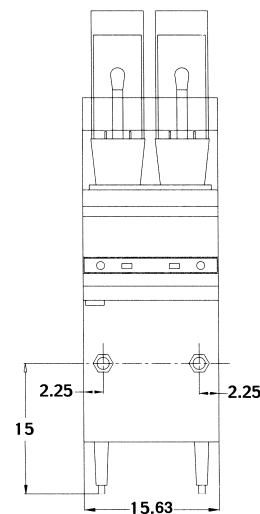

Front View

