



Over 90 Years Of Quality Foodservice
Products And Service

Job _____ Item No. _____

NSF-7 Slim Line Refrigerated Cold Pans

❑ RCP-7200SL ❑ RCP-7300SL ❑ RCP-7400SL

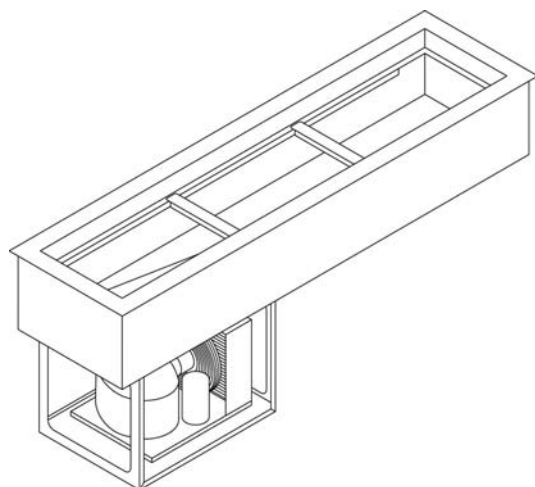

Model RCP-7300SL

DESCRIPTION

Wells Refrigerated Slim Line Drop-In Cold Pans are designed for narrow counters and hold pre chilled food products at cold, fresh and safe serving temperatures. All models are completely self-contained in two, three or four-well models and are CFC free. Pans are recessed 3" to comply with NSF-7 performance requirements. Includes an 8 ft. 120V cord and plug (120V models).

SPECIFICATIONS

Exterior – One-piece top flange and coved-corner interiors constructed of 18 gauge stainless steel. Exterior body constructed of heavy gauge, corrosion resistant steel. Condensing unit mounted on corrosion resistant frame below the cold pan.

Interior – CFC free foamed-in-place insulation through-out, 1" drain located in the center for easy cleaning. Ledge is recessed 3" to comply with NSF-7 requirements, allowing a layer of air to insulate food and for pan support.

Refrigeration – Air cooled, Type 404A CFC free refrigerant system featuring wrapped coil construction on both sides and bottom, individual thermostats, on/off switch, 8 ft. cord and plug set NEMA 5-15P (120V models). Refrigeration system features sight glass, easy service valves, dryer/filter and receiver. Condensing unit may be easily removed for service.

STANDARD FEATURES

- ❑ 3" recessed top edge to comply with NFS-7 requirements
- ❑ Self contained drop-in design
- ❑ Hold standard 12" by 20" food pans and fractional sized pans
- ❑ Stainless steel top and liner for maximum strength and durability
- ❑ 1" drains for ease of cleaning
- ❑ On-off switch with 8 ft. cord & plug for ease of installation and operation (120V models)
- ❑ Type- 404A CFC free refrigerant
- ❑ Fully insulated, CFC free, foamed-in place insulation keeps food cold while saving energy
- ❑ Recessed ledge for pan support and colder, fresher products
- ❑ Quick & easy service with sight glass, service valves, filter/dryer and receiver
- ❑ Limited 1 year parts & labor warranty

OPTIONS & ACCESSORIES

- ❑ 5-year compressor warranty
- ❑ Perforated bottom strainer plate conveniently holds ice above drain to prevent clogging
- ❑ Adaptor bars for fractional sized pans
- ❑ Remote on/off switch
- ❑ 220/230/240V
- ❑ 50 cycle
- ❑ Remote models (Includes compressor and condensing units and up to 20' leads)
- ❑ Remote models without compressors or condensing units
- ❑ 2nd year parts & labor warranty
- ❑ Special condenser orientation and/or compressor rack location

CERTIFICATIONS



Sheet No. WELLRCP7SL-02/12



Wells Bloomfield • 10 Sunnen Dr. St. Louis, MO 63143 U.S.A.
Phone : (314) 678-6314 • Fax (314) 781-3636
www.wellsbloomfield.com © 2012 Wells Bloomfield • Printed in the U.S.A.

NOTE: Specifications are subject to change without notice and are not intended for installation purposes. See installation instructions prior to installing the unit.