



# Heavy-Duty Juice Extractor with Pulp Ejection

WJX50

## Features

- Rapidly produces large volumes of rich, pulp-free juice
- 1+ HP, 850 watts – 2-speed operation
- RPMs: 13,000 on high, 6,500 on low
- Large 3" feed chute can fit whole apples
- Brushed stainless steel housing
- Stainless steel extraction basket with die-cast steel hub
- Easy-to-remove pulp collector
- Dual interlock for safe operation
- Limited One Year Motor Warranty





# Heavy-Duty Juice Extractor with Pulp Ejection



## WJX50

### Specifications

Item	Electrical	Listings	Dimensions (H" x W" x D")	Warranty
WJX50	120 VAC, 60 Hz	UL, NSF	17.5" x 13" x 10"	Limited 1 Year

### Ordering Information

Description	Catalog #	Std Pkg.	Ship Wt. (Lbs.)	Cubic Feet	UPC Code
Heavy-Duty Juice Extractor with Pulp Ejection	WJX50	2	30.4	4.06	040072006395

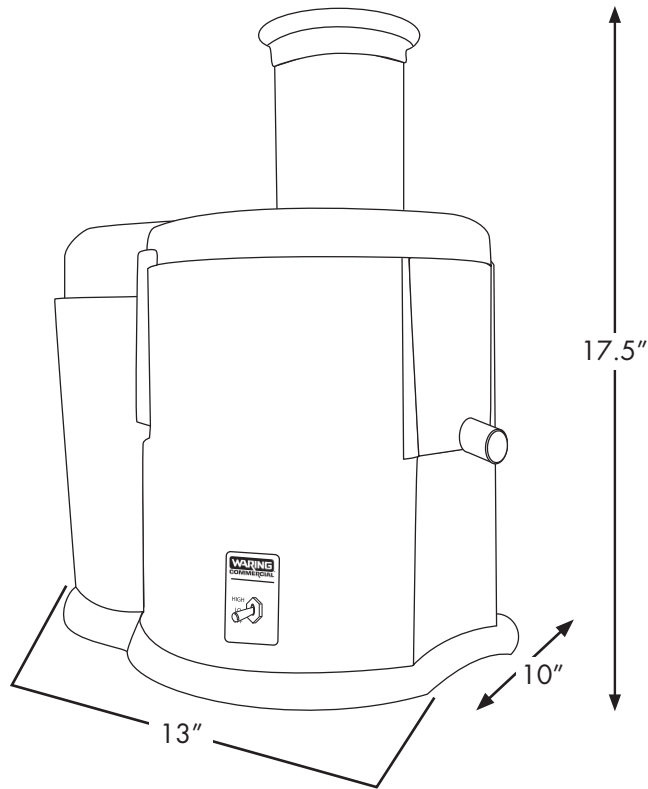

Waring Commercial • 314 Ella T. Grasso Ave. • Torrington • Connecticut 06790  
Tel. (800) 492-7464 • Fax (860) 496-9008 • [www.waringproducts.com](http://www.waringproducts.com) • ©2007