

WARING® COMMERCIAL TOASTERS



Features

- Uniformly Toasts Regular Bread, Texas Toast, Frozen Waffles, and Many Other Foods
- Full brushed stainless steel housing
- Easily Replaceable Industrial Heating Plates
- Standard 4-slice, combination bread and bagel and dedicated bagel toasters available
- Bagel Slots Toast on Cut Side Only
- Electronic Browning Controls
- Carriage Control Levers
- Dishwasher-Safe Crumb Tray
- Limited One Year Warranty

Heavy-Duty Commercial, Combination & Bagel Toasters



WCT810/WCT815/WCT815B
Combination Toasters



WCT820
Bagel Toaster



WCT800RC/WCT800
WCT805/WCT805B
Standard 4-Slice Toasters



Specifications

| Item | Electrical | Listings | Watts | Amps | Plug | Dimensions (H" x W" x D") | Warranty |
|----------|--------------------|--------------|-------|------|--------------|------------------------------|----------------|
| WCT800RC | 120 Volt, 50/60 Hz | UL, CUL, NSF | 1800 | 15 | NEMA 5-15P Ⓢ | 9" x 11 7/8" x 10 1/2" | Limited 1 Year |
| WCT800 | 120 Volt, 50/60 Hz | ETL, NSF | 2200 | 19 | NEMA 5-20P Ⓢ | 9" x 11 7/8" x 10 1/2" | Limited 1 Year |
| WCT805B | 208 Volt, 50/60 Hz | UL, CUL, NSF | 2700 | 13 | NEMA 6-15P Ⓢ | 9" x 11 7/8" x 10 1/2" | Limited 1 Year |
| WCT805 | 240 Volt, 50/60 Hz | UL, CUL, NSF | 2700 | 12 | NEMA 6-15P Ⓢ | 9" x 11 7/8" x 10 1/2" | Limited 1 Year |
| WCT810 | 120 Volt, 50/60 Hz | ETL, NSF | 2025 | 17 | NEMA 5-20P Ⓢ | 9" x 11 7/8" x 10 1/2" | Limited 1 Year |
| WCT815B | 208 Volt, 50/60 Hz | UL, CUL, NSF | 2025 | 10 | NEMA 6-15P Ⓢ | 9" x 11 7/8" x 10 1/2" | Limited 1 Year |
| WCT815 | 240 Volt, 50/60 Hz | UL, CUL, NSF | 2025 | 9 | NEMA 6-15P Ⓢ | 9" x 11 7/8" x 10 1/2" | Limited 1 Year |
| WCT820 | 120 Volt, 50/60 Hz | ETL, NSF | 1500 | 12.5 | NEMA 5-15P Ⓢ | 9" x 11 7/8" x 10 1/2" | Limited 1 Year |

Ordering Information

| Description | Catalog # | Std Pkg. | Ship Wt. (Lbs.) | Cubic Feet | UPC Code |
|--|-----------|----------|--------------------|------------|--------------|
| Heavy-Duty 120V Standard Toaster | WCT800RC | 1 | 22 lbs. | 1.6 | 040072002915 |
| Heavy-Duty 120V Standard Toaster | WCT800 | 1 | 22 lbs. | 1.6 | 040072001451 |
| Heavy-Duty 208V Standard Toaster | WCT805B | 1 | 22 lbs. | 1.6 | 040072003196 |
| Heavy-Duty 240V Standard Toaster | WCT805 | 1 | 22 lbs. | 1.6 | 040072001468 |
| Heavy-Duty 120V Combination Toaster | WCT810 | 1 | 22 lbs. | 1.6 | 040072001475 |
| Heavy-Duty 208V Combination Toaster | WCT815B | 1 | 22 lbs. | 1.6 | 040072003219 |
| Heavy-Duty 240V Combination Toaster | WCT815 | 1 | 22 lbs. | 1.6 | 040072001482 |
| Heavy-Duty 120V Bagel Toaster | WCT820 | 1 | 22 lbs. | 1.6 | 040072010019 |

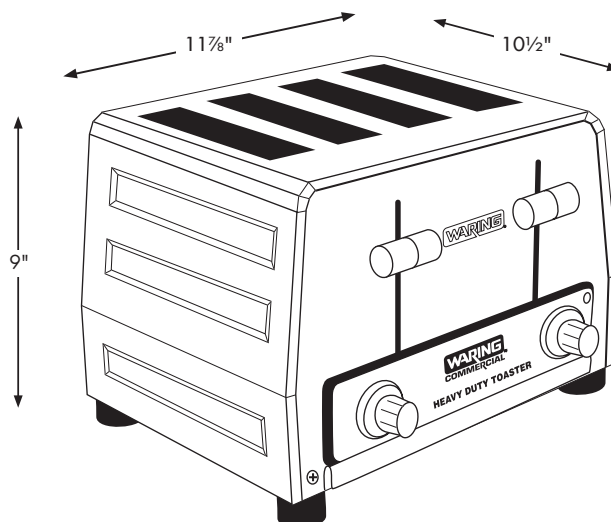

**Measurements
are the same
for all models.*