



Super Mixer II – Heavy-Duty Spindle Drink Mixer

DMC105V

Features

- Heavy-Duty 1.2 HP Variable Speed Motor
- 12,500 RPM on High
- Makes thick mixtures from hard ice cream, frozen custards and yogurts
- High-Efficiency Stainless Steel Agitator
- Solid Brushed Stainless Steel Construction
- Splash Guard for clean operation
- Front Mounted On/Off Switch
- Optional Foot Control
- Limited Two-Year Warranty





Super Mixer II– Heavy Duty Spindle Drink Mixer – DMC105V



Specifications

Item	Electrical	RPM	Listings	Dimensions (H" x W" x D")	Warranty
DMC105V	120 VAC 50/60 HZ 6' cord	12,500 on high (no load)	cULus, NSF	25 3/8" x 9" x 9"	Limited 2 Year

Ordering Information

Description	Catalog #	Std Pkg.	Ship Wt. (Lbs.)	Cubic Feet	UPC Code
Heavy-Duty Spindle Drink Mixer with rugged stainless steel enclosure	DMC105V	1	34.1	3.3	040072008368
On/Off Foot Control	CAC51	1	2	.09	040072930287

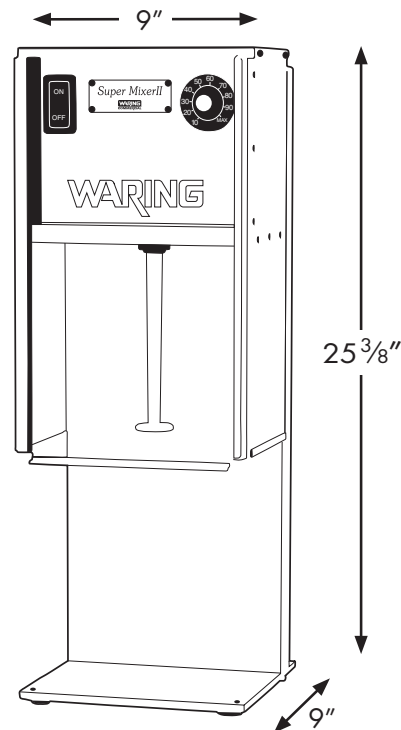

Waring Commercial • 314 Ella T. Grasso Ave. • Torrington • Connecticut 06790
 Tel. (800) 492-7464 • Fax (860) 496-9008 • www.waringproducts.com • ©2007