



# Commercial Conveyor Toasting Systems

CTS1000/CTS1000CND/CTS1000B

## Features

- Super-high output;  
CTS1000/CTS1000CND  
– 450 slices per hour  
CTS1000B  
– 1000+ slices per hour
- Ultra-fast, 5-minute heat-up time
- Large 2" opening accommodates thick breads and bagels
- Speed control and energy-saving standby functions
- Heavy-duty, brushed stainless steel construction
- Power On and Toaster Ready indicator lights
- Cool-touch side panels
- Lightweight and portable with thermo-insulated carrying handles
- Limited One Year Warranty





# Commercial Conveyor Toasting Systems



## CTS1000/CTS1000CND/CTS1000B

### Specifications

Item	Electrical	Plug-Type	Listings	Dimensions (H" x W" x D")	Warranty
CTS1000	120 Volt, 15A, 1800W	NEMA 5-15P	UL, NSF	13.5" x 15.5" x 19.5"	Limited One Year
CTS1000CND	120 Volt, 12.5A, 1500W	NEMA 5-15P	CUL, NSF	13.5" x 15.5" x 19.5"	Limited One Year
CTS1000B	208 Volt, 13A, 2700W	NEMA 6-20P	cULus, NSF	17.25" x 17" x 19.5"	Limited One Year

### Ordering Information

Description	Catalog #	Std Pkg.	Ship Wt. (lbs.)	Cubic Feet	UPC Code
Commercial Conveyor Toaster	CTS1000	1	33.8	4.28	040072007200
Commercial Conveyor Toaster	CTS1000CND	1	33.8	4.28	040072012525
Commercial Conveyor Toaster	CTS1000B	1	37	4.4	040072011061

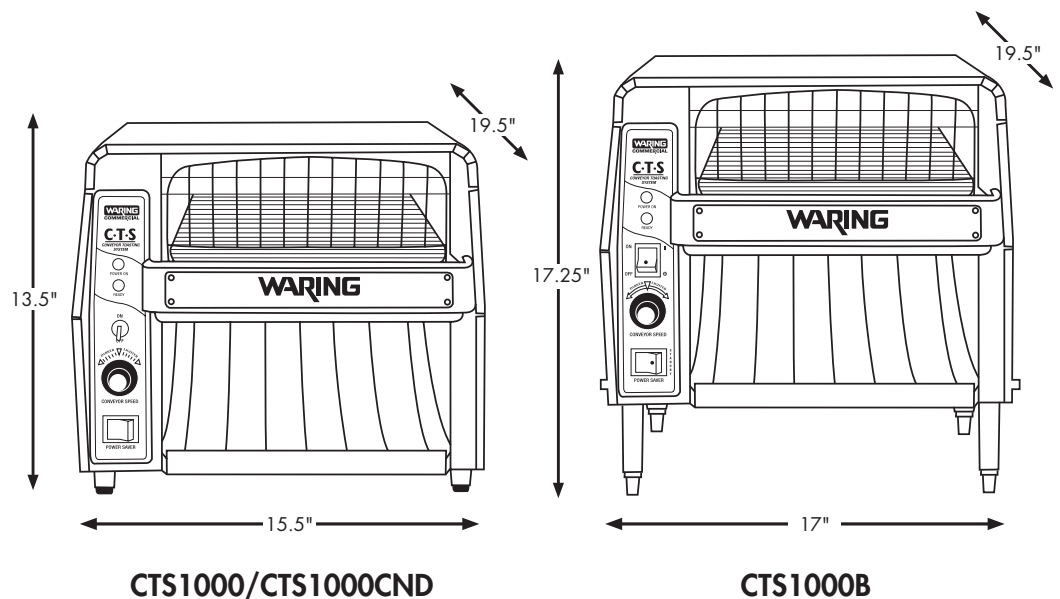

Waring Commercial • 314 Ella T. Grasso Ave. • Torrington • Connecticut 06790  
 Tel. (800) 492-7464 • Fax (860) 496-9008 • www.waringproducts.com  
 ©2009 Conair Corporation

09WC12035  
 PG-20353