

**HOLDING & TRANSPORT****VULCAN****VBP7I  
HOLDING & TRANSPORT CABINET**

Model VBP7I



UL listed. UL listed to Canadian safety standards.  
Classified by UL to NSF Std. #4.

**SPECIFICATIONS**

Vulcan Hart Model No. VBP7I heated holding and transport cabinets. Blower motor for gentle and even temperature distribution. Complete with full perimeter bumper and 5" heavy duty casters (2 swivel with brakes and 2 rigid). Recessed control panel containing dual indicator light, thermometer, and full range thermostat for temperatures up to 190°F (88°C). Cabinet capacity is 7 each 18" x 26" sheet pans, 14 each 12" x 20" x 2½" steam table pans, or a combination of both on 3" centers. Complete with 5 pairs of universal tray slides adjustable on 1½" centers. Cabinet interior and exterior are both constructed out of 20 gauge stainless steel. Recessed side-mounted lift handles, magnetic action door latch, and full insulation; 1½" in side walls and 2" in top. Integrated steel frame for maximum strength. Field reversible doors. Complete with top mounted cord, cord wrap, and plug: NEMA 5-15 for 120 volts and NEMA 6-15 for 208-240 volts. 120 volts, 1,000 watts, 8.3 amps. Lifetime warranty on heating elements.

**Exterior Dimensions:**

29" W x 33¾" D x 40" H

**VBP7I** Holding & Transport Cabinet

**STANDARD FEATURES**

- Holding and Transport Capacity:
  - 7 each – 18" x 26" sheet pans
  - 14 each – 12" x 20" x 2½" pans or a combination of both on 3" centers
- Blower motor for gentle and even temperature distribution
- Full perimeter bumper
- 5" heavy duty casters (2 with swivel with brakes and 2 rigid)
- Recessed side mounted lift handles
- Recessed control panel
- Dual indicator lights
- Thermometer
- Full range thermostat for temperatures up to 190°F (88°C)
- Five pairs of universal tray slides adjustable on 1½" centers
- Interior and the exterior are both constructed out of 20 gauge stainless steel
- Fully insulated with 1½" in side walls and 2" in top
- Integrated steel frame for maximum strength
- Magnetic action door latch
- Field reversible doors
- Top mounted cord
- Complete with cord and plug: NEMA 5-15 for 120 volts and NEMA 6-15 for 208-240 volts
- 120 volt, 1,000 watts, 8.3 amps
- Cord wrap
- Lifetime warranty on the heating elements

**OPTIONS**

- 208/240 volt
- Additional universal tray slides
- Humidity pan
- Glass door

**VULCAN**

a division of ITW Food Equipment Group LLC

P.O. Box 696 ■ Louisville, KY 40201 ■ Toll-free: 1-800-814-2028 ■ Local: 502-778-2791 ■ Quote & Order Fax: 1-800-444-0602



**VBP7I**  
HOLDING & TRANSPORT CABINET

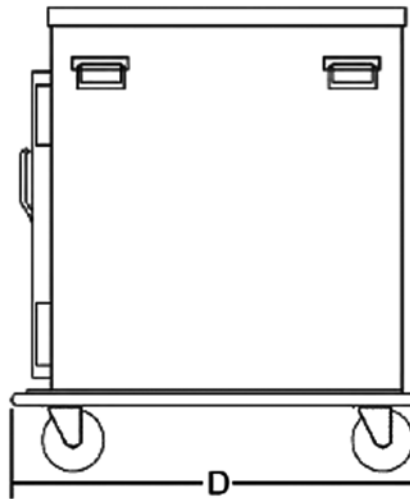
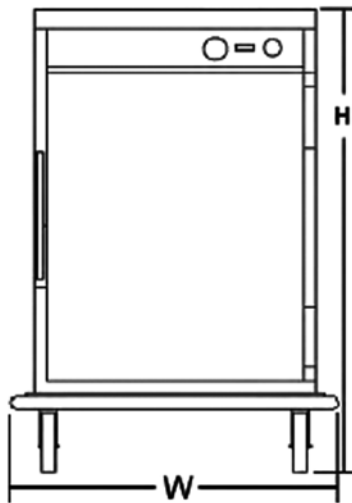
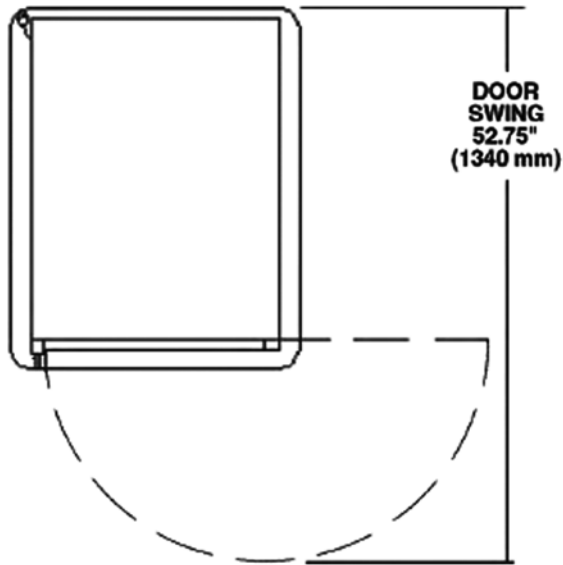

CAPACITY		DIMENSIONS	ELECTRICAL			SHIPPING WEIGHTS
12" x 20" x 2½" PANS	18" x 26" SHEET PANS	EXTERIOR	VOLTS	WATTS	AMPS	LBS / KG
14	7	29" W x 33¾" D x 40" H	120	1,000	8.3	208 lbs. / 94 kg.



a division of ITW Food Equipment Group LLC

P.O. Box 696 ■ Louisville, KY 40201 ■ Toll-free: 1-800-814-2028 ■ Local: 502-778-2791 ■ Quote & Order Fax: 1-800-444-0602

**NOTE:** In line with its policy to continually improve its products, Vulcan reserves the right to change materials and specifications without notice.