



**TRUE FOOD SERVICE
EQUIPMENT, INC.**

2001 East Terra Lane • O'Fallon, Missouri 63366
(636)240-2400 • Fax (636)272-2408 • (800)325-6152 • Intl Fax# (001)636-272-7546
Parts Dept. (800)424-TRUE • Parts Dept. Fax# (636)272-9471 • www.truemfg.com

Project Name: _____

Location: _____

Item #: _____ Qty: _____

Model #: _____

A/A #

SIS #

Model:
TPP-67

Food Prep Table:
Solid Door Pizza Prep Table



TPP-67

- ▶ True's pizza prep tables are designed with enduring quality that protects your long term investment.
- ▶ Oversized, environmentally friendly (R134A) forced-air refrigeration system holds 33°F to 41°F (.5°C to 5°C).
- ▶ Complies with and listed under ANSI/NSF-7-1997-6.3.
- ▶ All stainless steel front, top and ends. Matching aluminum finished back.
- ▶ Stainless steel, patented, foam insulated flat lids keep pan temperatures colder, lock in freshness, and minimize condensation.
- ▶ Extra-deep 19 1/2" (496 mm) full length removable cutting board included. Sanitary, high density, NSF approved white polyethylene provides tough preparation surface.
- ▶ Heavy duty PVC coated wire shelves.
- ▶ Foamed-in-place using Ecomate. A new, innovative, high density, polyurethane insulation that has zero ozone depletion potential (ODP) and zero global warming potential (GWP).

ROUGH-IN DATA

Specifications subject to change without notice.
Chart dimensions rounded up to the nearest 1/8" (millimeters rounded up to next whole number).

Model	Doors	Shelves	Pans (top)	Cabinet Dimensions (inches) (mm)			HP	Voltage	Amps	NEMA Config.	Cord Length (total ft.) (total m)	Crated Weight (lbs.) (kg)
				L**	D†	H*						
TPP-67	2	4	9	67 1/4	32 1/4	35 3/4	1/3	115/60/1	8.6	5-15P	7	405
				1709	820	909	1/3	230-240/50/1	3.9	▲	2.13	184

** Length does not include 1/4" (7 mm) each side for cutting board brackets and thumb screws.

† Depth does not include 1" (26 mm) for rear bumpers and 3" (77 mm) for cutting board.

* Height does not include 6 1/4" (159 mm) for castors or 6" (153 mm) for optional legs.

▲ Plug type varies by country.



APPROVALS:

AVAILABLE AT:

Model:
TPP-67

Food Prep Table: Solid Door Pizza Prep Table



STANDARD FEATURES

DESIGN

- True's commitment to using the highest quality materials and oversized refrigeration systems provides the user with colder product temperatures, lower utility costs, exceptional food safety and the best value in today's food service marketplace.

REFRIGERATION SYSTEM

- Factory engineered, self-contained, capillary tube system using environmentally friendly (CFC free) 134A refrigerant.
- Oversized, factory balanced refrigeration system with guided airflow to provide uniform temperature in food pan rail and cabinet interior.
- Forced-air design holds 33°F to 41°F (.5°C to 5°C) product temperature in food pans and cabinet interior. Complies with and listed under ANSI/NSF-7-1997-6.3.
- Condensing unit accessed from behind front removable panel, slides out for easy maintenance.

CABINET CONSTRUCTION

- Exterior - stainless steel front, top and ends. Matching aluminum finished back.
- Interior - attractive, NSF approved, white aluminum liner. 300 series stainless steel floor with coved corners.
- Insulation - entire cabinet structure and solid doors are foamed-in-place using Ecomate. A high density, polyurethane insulation that has zero ozone depletion potential (ODP) and zero global warming potential (GWP).
- 5" (127 mm) diameter stem castors. 36" (915 mm) work surface height.

DOORS

- Stainless steel exterior with white aluminum liner to match cabinet interior.

- Each door fitted with 12" (305 mm) long recessed handle that is foamed-in-place with a sheet metal interlock to ensure permanent attachment.
- Positive seal doors swing within cabinet dimensions.
- Magnetic door gaskets of one piece construction, removable without tools for ease of cleaning.

SHELVING

- Four (4) adjustable, heavy duty PVC coated wire shelves 23⁵/₈" L x 28" D (601 mm x 712 mm). Four (4) chrome plated shelf clips included per shelf.
- Shelf support pilasters made of same material as cabinet interior; shelves are adjustable on 1/2" (13 mm) increments.

MODEL FEATURES

- Evaporator is epoxy coated to eliminate the potential of corrosion.
- Extra-deep 19¹/₂" (496 mm), full length removable cutting board included. Sanitary, high-density, NSF approved white polyethylene provides tough preparation surface.
- Stainless steel, patented, foam insulated flat lids keep pan temperatures colder, lock in freshness, and minimize condensation.
- Refrigerated pan rail comes standard with nine (1/2 size) 12³/₄" L x 6¹/₄" W x 6" D (324 mm x 159 mm x 153 mm) NSF approved clear polycarbonate insert pans.
- NSF-7 compliant for open food product.

ELECTRICAL

- Unit completely pre-wired at factory and ready for final connection to a 115/60/1 phase, 15 amp dedicated outlet. Cord and plug set included.

OPTIONAL FEATURES/ACCESSORIES

Upcharge and lead times may apply.

- 230 - 240V / 50 Hz.
- 6" (153 mm) standard legs.
- 6" (153 mm) seismic/flanged legs.
- 4" (102 mm) diameter castors.
- 3" (85 mm) diameter castors.
- 2¹/₂" (64 mm) diameter castors.
- Barrel locks (factory installed). Requires one per door.
- Garnish rack.
- Single overshef.
- Double overshef.
- Half bun tray rack. Each holds up to eleven 18" L x 26" D (458 mm x 661 mm) sheet pans (sold separately).
- 19¹/₂" (496 mm) deep, 1/2" (13 mm) thick, white polyethylene cutting board.
- 19¹/₂" (496 mm) deep, 1/2" (13 mm) thick, composite cutting board.
- Half bun tray rack(s). Holds up to eleven 18" L x 26" D (458 mm x 661 mm) sheet pans (sold separately).
- Exterior round digital temperature display (factory installed).
- Remote cabinets (condensing unit supplied by others; system comes standard with 404A expansion valve and requires R404A refrigerant). Consult factory technical service department for BTU information. All remote units must be hard wired during installation.



115/60/1
NEMA-5-15R

PLAN VIEW

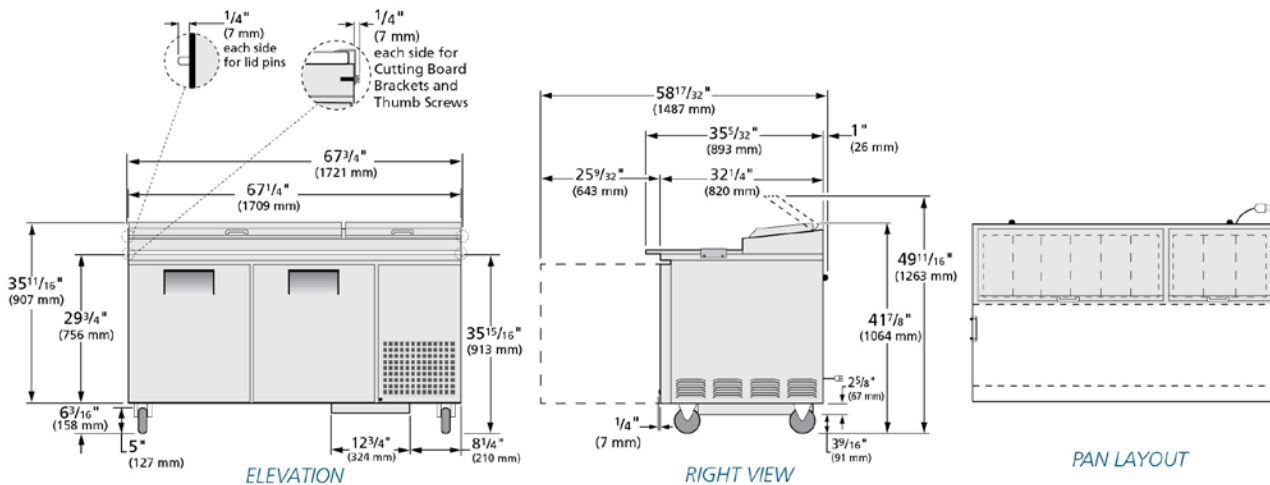

WARRANTY
One year warranty on all parts and labor and an additional 4 year warranty on compressor. (U.S.A. only)

METRIC DIMENSIONS ROUNDED UP TO THE NEAREST WHOLE MILLIMETER
SPECIFICATIONS SUBJECT TO CHANGE WITHOUT NOTICE



Model	Elevation	Right	Plan	3D	Back
TPP-67	TFQY11E	TFQY15S	TFQY11P	TFQY113	

TRUE FOOD SERVICE EQUIPMENT

2001 East Terra Lane • O'Fallon, Missouri 63366 • (636)240-2400 • Fax (636)272-2408 • (800)325-6152 • Intl. Fax# (001)636-272-7546 • www.truemfg.com