



**TRUE FOOD SERVICE  
EQUIPMENT, INC.**

2001 East Terra Lane • O'Fallon, Missouri 63366  
(636)240-2400 • Fax (636)272-2408 • (800)325-6152 • Intl Fax# (001)636-272-7546  
Parts Dept. (800)424-TRUE • Parts Dept. Fax# (636)272-9471 • www.truemfg.com

Project Name: \_\_\_\_\_

Location: \_\_\_\_\_

Item #: \_\_\_\_\_ Qty: \_\_\_\_\_

Model #: \_\_\_\_\_

A/A #

SIS #

Model:  
**TDD-2**

**Underbar Refrigeration:**  
*Solid Swing Door Direct Draw Beer Dispenser*



**TDD-2**

- ▶ True's direct draw beer dispensers are designed with enduring quality and value. Our commitment to using the highest quality materials and oversized refrigeration assures colder product temperatures and years of trouble free service.
- ▶ Oversized, factory balanced, refrigeration system holds 33°F to 38°F (.5°C to 3.3°C).
- ▶ Exterior - heavy duty, wear resistant laminated black vinyl front and sides. Matching black aluminum back. All stainless steel counter top.
- ▶ Interior - 300 series stainless steel floor with ½" (13 mm) reinforced lip and heavy gauge galvanized steel walls. NSF-7 approved for packaged and bottled product.
- ▶ Two (2) 3" (77 mm) diameter stainless steel insulated beer columns. Cold air is directed into beer columns to reduce foaming and maximize draft beer profits.
- ▶ Entire cabinet structure and solid doors are foamed-in-place using Ecomate. A high density, polyurethane insulation that has zero ozone depletion potential (ODP) and zero global warming potential (GWP).

**ROUGH-IN DATA**

Specifications subject to change without notice.  
Chart dimensions rounded up to the nearest ⅛" (millimeters rounded up to next whole number).

| Model | Doors | Capacity<br>½<br>Barrels | Cabinet Dimensions<br>(inches)<br>(mm) |     |     | HP | Voltage      | Amps | NEMA<br>Config. | Cord<br>Length<br>(total ft.)<br>(total m) | Crated<br>Weight<br>(lbs.)<br>(kg) |
|-------|-------|--------------------------|--|-----|-----|----|--------------|------|-----------------|--|------------------------------------|
|       |       |                          | L                                      | D†  | H*  |    |              |      |                 |  |                                    |
| TDD-2 | 2     | 2                        | 58⅞                                    | 27⅞ | 37  | ⅓  | 115/60/1     | 8.5  | 5-15P           | 7  | 310                                |
|       |       |                          | 1496                                   | 689 | 940 | ⅓  | 230-240/50/1 | 4.2  |                 |  |                                    |

† Depth does not include 1" (26 mm) for rear bumpers.  
\* Height does not include 15¼" (388 mm) for draft arms.

▲ Plug type varies by country.

|  |                   |                      |
|--|-------------------|----------------------|
|  | <b>APPROVALS:</b> | <b>AVAILABLE AT:</b> |
|  | 12/10             | Printed in U.S.A.    |

Model:  
**TDD-2**

# Underbar Refrigeration: Solid Swing Door Direct Draw Beer Dispenser



## STANDARD FEATURES

### DESIGN

- True's direct draw beer dispensers are designed with enduring quality and value. Our commitment to using the highest quality materials and oversized refrigeration assures colder product temperatures and years of trouble free service.

### REFRIGERATION SYSTEM

- Factory engineered, self-contained, capillary tube system using environmentally friendly (CFC free) 134A refrigerant.
- Extra large evaporator coil balanced with higher horsepower compressor and large condenser; maintains cabinet temperatures of 33°F to 38°F (.5°C to 3.3°C).
- Sealed, cast iron, self-lubricating evaporator fan motor(s) and larger fan blades give True beer dispensers a more efficient low velocity, high volume airflow design. This unique design ensures faster temperature pull down of warm product, colder holding temperatures and faster recovery in high use situations.
- Condensing unit accessed from behind front grill, slides out for easy cleaning and maintenance.

### CABINET CONSTRUCTION

- Exterior - heavy duty, wear resistant laminated black vinyl front and sides. Matching black aluminum back. All stainless steel counter top.
- Interior - 300 series stainless steel floor with 1/2" (13 mm) reinforced lip and heavy gauge galvanized steel walls.

- Door threshold protector prevents damage to cabinet from routine loading of product.
- Insulation - entire cabinet structure and solid doors are foamed-in-place using Ecomate. A high density, polyurethane insulation that has zero ozone depletion potential (ODP) and zero global warming potential (GWP).
- Welded, heavy duty steel frame rail, black powder coated for corrosion protection.
- Two (2) 3" (77 mm) diameter stainless steel insulated beer columns. Cold air is directed into beer column(s) to reduce foaming and maximize draft beer profits.

### DOORS

- Wear-resistant laminated black vinyl exterior with heavy gauge galvanized steel liner.
- Each door fitted with 12" (305 mm) long recessed handle that is foamed-in-place with a sheet metal interlock to ensure permanent attachment.
- Positive seal doors.
- Magnetic door gasket(s) of one piece construction, removable without tools for ease of cleaning.
- Door locks standard.

### LIGHTING

- Incandescent interior lighting.

### MODEL FEATURES

- Evaporator is epoxy coated to eliminate the potential of corrosion.
- Convenient 1/2" (13 mm) barbed T drain fitting located on front of cooler.

- Designed to accommodate all types of beer kegs.
- Comes standard with a two-way tapper manifold.
- Listed under NSF-7 for the storage and/or display of packaged or bottled product.

### ELECTRICAL

- Unit completely pre-wired at factory and ready for final connection to a 115/60/1 phase, 15 amp dedicated outlet. Cord and plug set included.



115/60/1  
NEMA-5-15R

### OPTIONAL FEATURES/ACCESSORIES

Upcharge and lead times may apply.

- 230 - 240V / 50 Hz.
- 6" (153 mm) standard legs.
- 6" (153 mm) seismic/flanged legs.
- 2 1/2" (64 mm) diameter castors.
- 4" (102 mm) diameter castors.
- Double headed draft column.
- Triple headed draft column.
- Three-way tapper manifold.
- Draft cap.
- Remote cabinets (condensing unit supplied by others; system comes standard with 404A expansion valve and requires R404A refrigerant). Consult factory technical service department for BTU information. All remote units must be hard wired during installation.

## PLAN VIEW

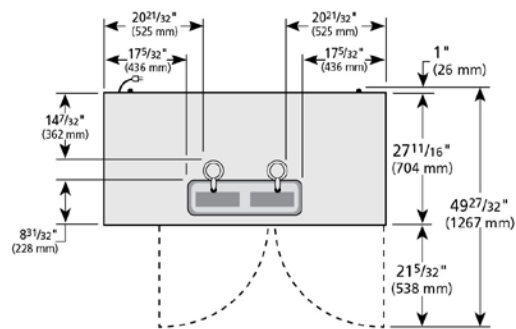
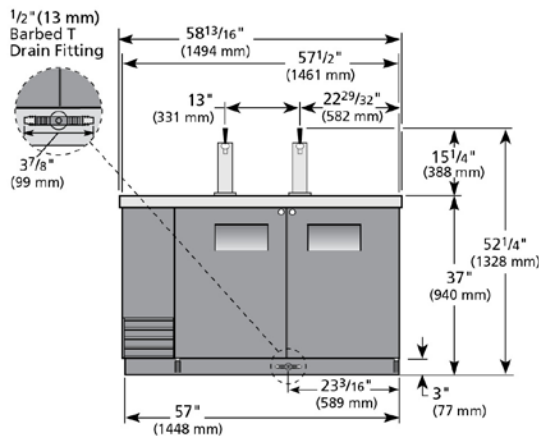

**WARRANTY**  
One year warranty on all parts and labor and an additional 4 year warranty on compressor. (U.S.A. only)

METRIC DIMENSIONS ROUNDED UP TO THE NEAREST WHOLE MILLIMETER  
SPECIFICATIONS SUBJECT TO CHANGE WITHOUT NOTICE



| Model | Elevation | Right   | Plan    | 3D      | Back |
|-------|-----------|---------|---------|---------|------|
| TDD-2 | TFHY03E   | TFHY03S | TFHY03P | TFHY033 |      |

## TRUE FOOD SERVICE EQUIPMENT

2001 East Terra Lane • O'Fallon, Missouri 63366 • (636)240-2400 • Fax (636)272-2408 • (800)325-6152 • Intl. Fax# (001)636-272-7546 • www.truefmfg.com