

Economy Pizza Press

- Digital control with timer and counter.
- Adjustable thickness control.
- Heated upper platen helps cold dough flow faster.
- Manually operated, no motor or compressors required.
- Flattens all size pizzas up to and including 18" (46 cm) diameter.
- Produces crusts equal to hand tossed product.
- Safe to operate and clean.
- Compact size fits just about anywhere.
- Fast cleaning since no flour required.



Listed.

ON/OFF Switch	Yes	Electrical Data 120v/60hz 1450w/12.5amps 240v/50/60hz 1450w/6.04amps
Automatic Timer	Yes	
Adjustable Thickness	Yes	
Temperature Control	Yes	Shipping Weight's 150 lbs. / 70 kgs.
Maximum Heat	0-450°F	

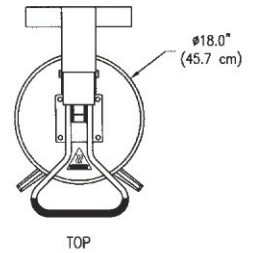
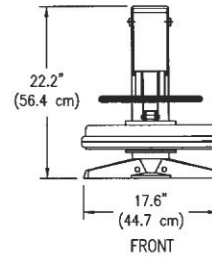
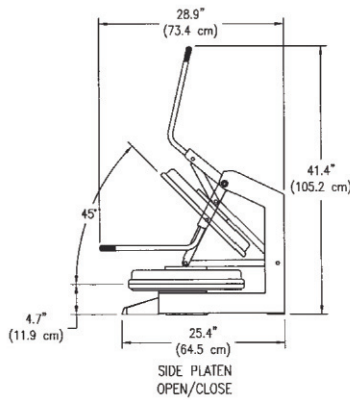

Operating the PP1818 is simple, requiring only minutes of instruction:



After allowing upper platen to reach desired temperature, place pre-portioned ball of dough in approximate center of lower plate. An approved lubricant/release agent such as olive oil or DOUGHPRO's Cookware Food Release Spray # DPPC1 applied to the top of the dough ball will greatly improve the pressing operation.



Pull down the handle till it locks into position. Once the bar is locked into position wait until your desired timer setting is done. Then with both hands pull up the handle, unlocking it.



Lift up handle. Remove your crust from either the left or right side. Place flattened crust on screen, disc or pan. Now you're ready for make-up and baking. **Always keep in mind that the final crust shape and size are result of proper portioning and rounding.**

Specifications, Details and Prices are subject to change without prior notice. Please call for current pricing.

DOUGHPRO
20281 Harvill Ave, Perris, CA 92570
(951) 657-0379 (800) 624-6717 Fax (951) 657-4594

DOUGHPRO®
STEARNS PRODUCT DEVELOPMENT CORPORATION
Website: www.doughpro.com E-Mail: info@doughpro.com