



Front-Load Slicer

Key Features:

- Perfect for on-demand slicing of hard-crustured breads and soft-textured sandwich loaves
- Small footprint – less than 24” wide
- Large bread capacity - up to 16” loaves
- Easy-to-operate, with convenient, front-mounted push button controls
- Front-mounted bagging scoop that adjusts for smaller loaves makes for convenient bagging
- Blade advantages:
 - Uses the lowest cost replacement blades in the industry, contributing to low cost of ownership
 - Easily replaceable, independently mounted, rust-resistant blades
 - Blade replacement only takes one hour of labor, the lowest in the industry
- Smooth, quiet operation with minimal vibration



Front-Load Slicer with optional stainless steel stand



The information contained herein is correct to the best of our knowledge. The recommendations or suggestions are made without guarantee or representation as to results. Freedom from any patent owned by Oliver Packaging and Equipment or other is not to be inferred. Above specifications subject to change without notice



Manufactured in the U.S.A.



Oliver Packaging & Equipment Company
 511 Sixth Street NW • Grand Rapids, MI 49504
 (800) 253-3893 • (616) 356-2950 • www.oliverquality.com



Front-load Slicer

SPECIFICATIONS:

Motor:

1/2 H.P., single phase, 60Hz, 115 VAC, 7 AMPS;
230 VAC, 3.5 AMPS (additional charge)
Special electrics also available

Capacities:

16" (406 mm) long X 9" (228 mm) wide X
5 1/2" (140 mm) high

Finish:

Stainless steel contact components and
food-safe materials throughout

Slice Spacing:

Standard: 3/8" (10 mm), 7/16" (11 mm),
1/2" (13 mm), 5/8" (16 mm)

Also available at extra cost: 9/16" (14 mm),
3/4" (19 mm), 7/8" (22 mm), or 1" (25 mm)

Dimensions (see drawings at right):

Shipping weight:

300 lbs. (135 kg)

Net Weight:

250 lbs. (114 kg)

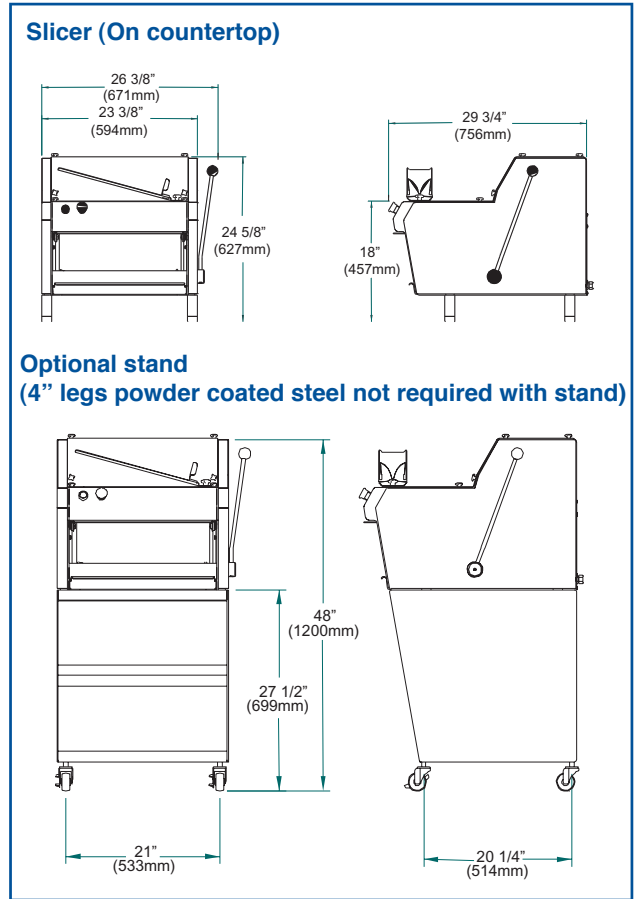

Manufactured under one or more of the following:
 U.S. Patent # 4,856,398 U.S. Patent # 4,759,168
 U.S. Patent # Des. 310,933 U.S. Patent # 5,243,921
 U.S. Patent # 5,461,956 U.S. Patent # 4,662,257
 U.S. Patent # 4,296,589 U.S. Patent # 4,196,561
 U.S. Patent # 4,194,341 U.S. Patent # 4,141,196
 U.S. Patent # 6,123,004
 Other U.S. and foreign patents pending.

The information contained herein is correct to the best of our knowledge. The recommendations or suggestions are made without guarantee or representation as to results. Freedom from any patent owned by Oliver Packaging and Equipment or other is not to be inferred.

Above specifications subject to change without notice

Manufactured in the U.S.A.



Oliver Packaging & Equipment Company
 511 Sixth Street NW • Grand Rapids, MI 49504
 (800) 253-3893 • (616) 356-2950 • www.oliverquality.com



Optional Front-load Slicer Stands

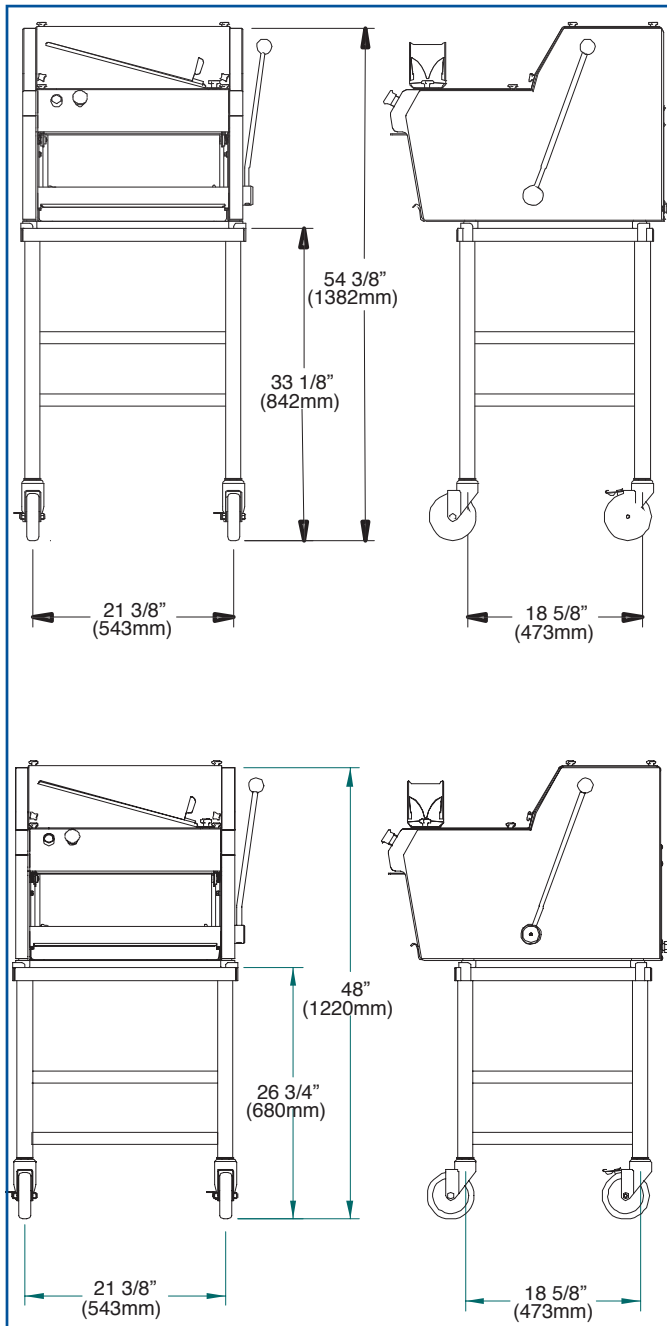

Optional 33 1/8" stainless steel stand
(4" legs not required with stand)

Optional 26 3/4" stainless steel stand
(4" legs not required with stand)

The information contained herein is correct to the best of our knowledge. The recommendations or suggestions are made without guarantee or representation as to results. Freedom from any patent owned by Oliver Packaging and Equipment or other is not to be inferred.

Above specifications subject to change without notice

Manufactured in the U.S.A.



Oliver Packaging & Equipment Company
511 Sixth Street NW • Grand Rapids, MI 49504
(800) 253-3893 • (616) 356-2950 • www.oliverquality.com