



***Q Model Flake/Chiptlet***  
***S Model Flake/Nugget***

**Technician's  
Handbook**

This manual is updated as new information and models are released. Visit our website for the latest manual.  
[www.manitowocice.com](http://www.manitowocice.com)

***America's #1 Selling Ice Machine***  
Part Number 80-1230-9 10/10



## Safety Notices

As you work on Manitowoc equipment, be sure to pay close attention to the safety notices in this handbook. Disregarding the notices may lead to serious injury and/or damage to the equipment.

Throughout this handbook, you will see the following types of safety notices:



### **Warning**

Text in a Warning box alerts you to a potential personal injury situation. Be sure to read the Warning statement before proceeding, and work carefully.



### **Caution**

Text in a Caution box alerts you to a situation in which you could damage the equipment. Be sure to read the Caution statement before proceeding, and work carefully.

## Procedural Notices

As you work on Manitowoc equipment, be sure to read the procedural notices in this handbook. These notices supply helpful information which may assist you as you work.

Throughout this handbook, you will see the following types of procedural notices:

### **Important**

Text in an Important box provides you with information that may help you perform a procedure more efficiently. Disregarding this information will not cause damage or injury, but it may slow you down as you work.

NOTE: Text set off as a Note provides you with simple, but useful, extra information about the procedure you are performing.

## Read These Before Proceeding:

### **Caution**

Proper installation, care and maintenance are essential for maximum performance and trouble-free operation of your Manitowoc equipment. If you encounter problems not covered by this handbook, do not proceed, contact Manitowoc Foodservice Group. We will be happy to provide assistance.

### **Important**

Routine adjustments and maintenance procedures outlined in this handbook are not covered by the warranty.

### **Warning**

#### **PERSONAL INJURY POTENTIAL**

Do not operate equipment that has been misused, abused, neglected, damaged, or altered/modified from that of original manufactured specifications.

We reserve the right to make product improvements at any time. Specifications and design are subject to change without notice.

# Table of Contents

---

## General Information

<b>Model Numbers</b> . . . . .	13
How to Read a Model Number . . . . .	14
Model/Serial Number Location . . . . .	15
Manitowoc Cleaner and Sanitizer . . . . .	15
Ice Machine Warranty Information . . . . .	15
<b>Q Model &amp; S Model Flake/Chiplet/Nugget Commercial Warranty</b> . . . . .	16
<b>Q Model &amp; S Model Flake/Chiplet/Nugget Res- idential Warranty</b> . . . . .	18

## Installation

<b>Location of Ice Machine</b> . . . . .	23
<b>Ice Machine Clearance Requirements</b> . . . . .	24
<b>Ice Machine Heat of Rejection</b> . . . . .	25
<b>Location of Traditional Remote Units and Re- mote condensing units</b> . . . . .	26
<b>Electrical Service</b> . . . . .	27
Circuit Ampacity . . . . .	28
<b>Ice Machine Head Section Water Supply and Drains</b> . . . . .	31
Potable Water Supply . . . . .	31
Potable Water Inlet Lines . . . . .	31
Drain Connections . . . . .	32
Cooling Tower Applications (Water-Cooled Models) . . . . .	32
Installing on a Dispenser . . . . .	33
Line Set Requirements . . . . .	34

## Component Identification

<b>QF400 Air-cooled</b> . . . . .	37
<b>QF800/QC700 Air &amp; Water-cooled</b> . . . . .	38
<b>SF0400/SN0450/SF0600/SN0650/SF0900/ SN0950/SF1200/SN1250 Air &amp; Water-cooled</b> . . . . .	39
<b>SF0600/SN0650/SF0900/SN0950/SF1200/ SN1250 Remote &amp; QuietQube Model</b> . . . . .	41

## Maintenance

<b>Manitowoc's Cleaning Technology</b> . . . .	44
Exterior Cleaning . . . . .	45
<b>Preventative Maintenance Procedure</b> . .	46
QF0400 . . . . .	46
QC0700/QF0800/QF2200/QF2300 . .	48
SN012/SN020/SF0400/SN0450/SF0600/ SN0650/SF0900/SN0950/SF1200/SN1250	50
<b>Heavily Scaled Procedure</b> . . . . .	53
QF0400 . . . . .	53
QC0700/QF0800/QF2200/QF2300 . .	54
SN012/SN020/SF0400/SN0450/SF0600/ SN0650/SF0900/SN0950/SF1200/SN1250	55
<b>Cleaning And Sanitizing Procedure</b> . . . .	57
QF0400 . . . . .	57
QC0700/QF0800/QF2200/QF2300 . .	60
SN012/SN020/SF0400/SN0450/SF0600/ SN0650/SF0900/SN0950/SF1200/SN1250	62
<b>Component Disassembly For Cleaning And Sanitizing</b> . . . . .	65
General Information . . . . .	65
QF400 . . . . .	66
QC0700/QF0800/QF2200/QF2300 . .	71
SN012/SN020 . . . . .	84
Water Dump Valve - All Models . . . . .	98
Cleaning the Condenser . . . . .	100
<b>Removal from Service/Winterization</b> . . .	102
General . . . . .	102
Self-Contained Air-Cooled or Remote Air- Cooled Ice Machines . . . . .	102
Water-Cooled Ice Machines . . . . .	103
Remote Ice Machines . . . . .	103

## Operation

<b>Ice Making Sequence of Operation</b> . . . . .	105
QF0400/QC0700/QF0800 . . . . .	105
QF2200 . . . . .	107
QF2300 . . . . .	112
SN012/SN020/SF0400/SN0450/SF0600/ SN0650/SF0900/SN0950/SF1200/SN1250 Nugget/Flake Machines . . . . .	116
Energized Parts . . . . .	119

## Troubleshooting

<b>SafeGuard Feature</b> . . . . .	121
<b>QF0400/QC0700/QF0800/QF2200/QF2300</b>	123
No Water SafeGuard . . . . .	123
Gear Motor Speed . . . . .	125
Temperature Is Too high Or Too Low .	127
QF2200 Only - Temperature Is Too High or Low . . . . .	130
<b>SN012/SN020/SF0400/SN0450/SF0600/ SN0650/SF0900/SN0950/SF1200/SN1250</b>	132
No Water . . . . .	132
No Ice Production . . . . .	133
<b>Diagnosing an Ice Machine That Will Not Run</b> . . . . .	135
QF0400/QC0700/QF0800/QF2200/QF2300 . . . . .	135
RFC0985/RFC1285/RFC2085/RFC2385 Diagnosing A Condensing Unit That Will Not Run . . . . .	136
QF0400/QC0700/QF0800/QF2200/QF2300 Operational Problem Checklist . . . . .	137
SN012/SN020/SF0400/SN0450/SF0600/ SN0650/SF0900/SN0950/SF1200/SN1250 . . . . .	140
<b>Refrigeration Diagnostics</b> . . . . .	146
Before Beginning Service . . . . .	146
Installation/Visual Inspection Checklist	146
Water System Checklist . . . . .	147
Ice Production/Quality Check . . . . .	148
Analyzing Discharge Pressure . . . . .	149
Analyzing Suction Pressure . . . . .	151

## Component Check Procedures

<b>QF0400/QC0700/QF0800/QF2200/QF2300</b>	153
Main Fuse . . . . .	153
ICE/OFF/CLEAN Toggle Switch . . . . .	154
Water Float Valve . . . . .	155
Water Level Check . . . . .	156
Bin Level Probe Diagnostics . . . . .	157
Water Level Probes . . . . .	161
Motor Speed Sensor . . . . .	165
Temperature Sensor . . . . .	167
<b>QF2200 Only</b> . . . . .	169
Low Pressure Cut-Out Control . . . . .	169
<b>QF2300 Only</b> . . . . .	170
Equalization Valve . . . . .	170
Electronic Bin Thermostat . . . . .	171
<b>S Model Nugget/Flake</b> . . . . .	176
Main Fuse . . . . .	176
ICE/OFF/CLEAN Toggle Switch . . . . .	177
Float Switch . . . . .	178
Ice Damper and Hall Effect Switches . . . . .	179
<b>SN012/SN020 Only</b> . . . . .	182
Selector Switch . . . . .	182
Dispense Switch . . . . .	183
Touchless Sensor . . . . .	184
<b>All Models</b> . . . . .	185
High Pressure Cutout Control . . . . .	185
Compressor Electrical Diagnostics . . . . .	187
Diagnosing Start Components . . . . .	189
<b>Self Contained Air Cooled Models</b> . . . . .	191
Fan Cycle Control . . . . .	191
<b>Self Contained Water-cooled Models</b> . . . . .	192
Water Regulating Valve . . . . .	192
<b>Headmaster Control Valve</b> . . . . .	193
<b>Refrigerant Recovery/Evacuation</b> . . . . .	195
Normal Self-Contained Procedures . . . . .	195
Remote Air-Cooled Models . . . . .	199
<b>System Contamination Clean-Up</b> . . . . .	202
Determining Severity Of Contamination . . . . .	202
Cleanup Procedure . . . . .	204
Replacing Pressure Controls Without Re- moving Refrigerant Charge . . . . .	207



<b>Gear Box Removal</b> .....	210
QF0400 .....	210
QC0700/QF0800 .....	212
QF2200/QF2300 .....	214
<b>Evaporator Re-Build Kits</b> .....	216
Identifying Correct Kit: .....	216
Cleaning Evaporator after Disassembly	219
Evaporator Reassembly .....	220
<b>EVAPORATOR REMOVAL</b> .....	222
QF0400 .....	222
QC0700/QF0800 .....	224
QF2200/QF2300 .....	226
<b>Component Specifications</b>	
Main Fuse .....	229
ICE/OFF/CLEAN Toggle Switch .....	229
Fan Cycle Control .....	229
High Pressure Cutout (HPCO) Control	229
Torque Values .....	229
Gearmotor RPMs .....	230
Filter-Driers .....	230
Suction Line Filter .....	231
Suction Cleanup Filter-Drier .....	231
<b>Total System Refrigerant Charge</b> .....	232

## Charts

<b>Cycle Times/24-Hour Ice Production/ Refrigerant Pressure Charts</b> . . . . .	233
SN012A/SN020A . . . . .	234
QF0400A Stainless Steel Evaporator .	235
QF0400A Bronze Evaporator . . . . .	236
SF0400A . . . . .	237
SF0400W . . . . .	238
SN0450A . . . . .	239
SN0450W . . . . .	240
SF0600A . . . . .	241
SF0600W . . . . .	242
SF0600N . . . . .	243
SN0650A . . . . .	244
SN0650W . . . . .	245
SN0650N . . . . .	246
QC0700A . . . . .	247
QC0700W . . . . .	248
QF0800A . . . . .	249
QF0800W . . . . .	250
SF900A . . . . .	251
SF900W . . . . .	252
SF900C/RFC985 . . . . .	253
SN950A . . . . .	254
SN950W . . . . .	255
SN950C/RFC985 . . . . .	256
SF1200A . . . . .	257
SF1200W . . . . .	258
SF1200C/RFC1285 . . . . .	259
SN1250A . . . . .	260
SN1250W . . . . .	261
SN1250C/RFC1285 . . . . .	262
QF2200/RFC2085 . . . . .	263
QF2300/RFC2385 . . . . .	264

## Diagrams

<b>Wiring Diagrams</b> . . . . .	265
QF0400 115/60/1 – 230/50/1 . . . . .	266
QC0700/QF0800 115/60/1 – 230/50/1 . . . . .	267
QC0700/QF0800 115/60/1 – 230/50/1 . . . . .	268
QC0700/QF0800 Compressor Section . . . . .	269
QF2200 115/60/1 – 230/50/1 . . . . .	270
RFC2085 Condensing Unit 230/60/1 – 230/50/1 . . . . .	271
RFC2085 Condensing Unit 208 - 230/60/3 . . . . .	272
QF2300 . . . . .	273
RFC2385 Condensing Unit . . . . .	274
RFC0985/RFC1285/RFC2385 Condensing Unit . . . . .	275
SN012/SN020 115/60/1 – 230/50/1 . . . . .	276
S Model Flake / Nugget Head Sections . . . . .	277
<b>Electronic Control Boards</b> . . . . .	278
S Model Flake/Nugget Control Boards . . . . .	278
Q Model Flake/Chiplet Control Boards . . . . .	280
<b>Refrigeration Tubing Schematics</b> . . . . .	281
QF0400/QC0700/QF0800 . . . . .	281
RFC2085 . . . . .	282
RFC985/RFC1285/RFC2185/RFC2385 . . . . .	283
SN012/SN020 . . . . .	284
SF0400/SN0450/SF0600/SN0650 . . . . .	285
SF0900/SN0950/SF1200/SN1250 . . . . .	286
SF0600/SN0650 . . . . .	287

**This Page Intentionally Left Blank**

# General Information

## Model Numbers

### Head Section Models

Self-Contained Air-Cooled	Self-Contained Water-Cooled	Traditional Remote Condenser	Remote Condensing Unit
SN012A (T)	NA	NA	NA
SN020A (T)	NA	N/A	NA
QF0406A	NA	NA	NA
SF0406A	SN0407W	NA	NA
SN0458A	SN0459W	NA	NA
SF0606A	SF0607W	SF0696N	NA
SN0658A	SN0659W	SN0698N	NA
QC0708A	QC0709W	NA	NA
QF0806A	QF0807W	NA	NA
SF0906A	SF0907W	NA	SF0976C
SN0958A	SN0959W	NA	SN0978C
SF1206A	SF1207W	NA	SF1276C
SN1258A	SN1259W	NA	SN1278C
NA	NA	NA	QF2296N
NA	NA	NA	QF2396N

### Remote Condenser Models

Head Section	Traditional Remote Condenser	Remote Condensing Unit
SN0650	JC0495	NA
SF0976C	NA	RFC0985
SN0978C	NA	RFC0985
SF1276C	NA	RFC1285
SN1278C	NA	RFC1285
QF2296N	NA	RFC2085
QF2396N	NA	RFC2385

NOTE: Model numbers ending in 3 indicate a 3-phase unit. Example: RFC12853

\* Traditional Remotes - condenser is outside, compressor is inside. The heat is rejected outside. Line set consists of a high pressure discharge line and a high pressure liquid line. Only models ending in "N" use Traditional Remote Condensers.

\*\* RFC Remote Condensing Unit - compressor, condenser, accumulator and head pressure control valve outside. Line set consists of a low pressure suction line and a high pressure liquid line. Only models ending in "C" use RFC Remote Condensing Units.

## HOW TO READ A MODEL NUMBER

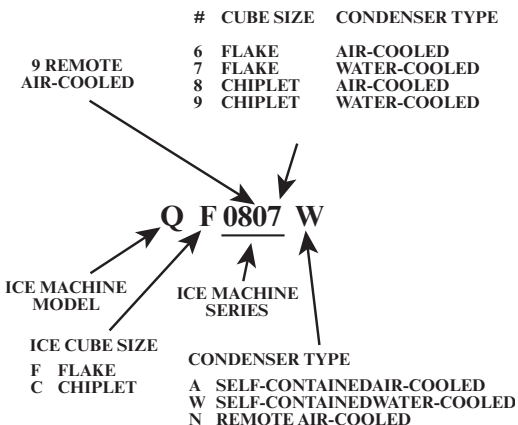

### Warning

#### Personal Injury Potential

The ice machine must be attached to the adapter and dispenser to prevent the ice machine from falling. Mounting brackets are provided with all Nugget ice machines.

## MODEL/SERIAL NUMBER LOCATION

These numbers are required when requesting information from your local Manitowoc Distributor, service representative, or Manitowoc Ice, Inc. The model and serial number are listed on the OWNER WARRANTY REGISTRATION CARD. They are also listed on the MODEL/SERIAL NUMBER DECAL affixed to the ice machine.

## MANITOWOC CLEANER AND SANITIZER

Manitowoc Ice Machine Cleaner and Sanitizer are available in 16 oz. (473 ml) bottles. These are the only cleaners and sanitizer approved for use with Manitowoc products.

### **Caution**

Flake/Chiptlet/Nugget models must use cleaner part number **000000084 ONLY** (clear cleaner). Damage to the evaporator will result with repeated use or high concentrations of standard (green) cleaner. This damage is not covered by the warranty.

Cleaner Part Number		Sanitizer Part Number	
16 oz.	000000084	16 oz.	94-0565-3
1 gal	N/A	1 gal.	94-0581-3

## ICE MACHINE WARRANTY INFORMATION

### Owner Warranty Registration Card

Warranty coverage begins the day the ice machine is installed.

### **Important**

Complete and mail the OWNER WARRANTY REGISTRATION CARD as soon as possible to validate the installation date.

If the OWNER WARRANTY REGISTRATION CARD is not returned, Manitowoc will use the date of sale to the Manitowoc Distributor as the first day of warranty coverage for your new ice machine.

## **Q Model & S Model Flake/Chiplet/Nugget Commercial Warranty**

Manitowoc Ice, Inc. (hereinafter referred to as the "COMPANY") warrants for a period of twenty four months from the installation date (except as limited below) that new Flake/Chiplet ice machines manufactured by the COMPANY shall be free of defects in material or workmanship under normal and proper use and maintenance as specified by the COMPANY and upon proper installation and start-up in accordance with the instruction manual supplied with the ice machine. The COMPANY'S warranty hereunder with respect to the compressor shall apply for an additional thirty-six months, excluding all labor charges.

The obligation of the COMPANY under this warranty is limited to the repair or replacement of parts, components, or assemblies that in the opinion of the COMPANY are defective. This warranty is further limited to the cost of parts, components or assemblies and standard straight time labor charges at the servicing location.

Time and hourly rate schedules, as published from time to time by the COMPANY, apply to all service procedures. Additional expenses including without limitation, travel time, overtime premium, material cost, accessing or removal of the ice machine, or shipping are the responsibility of the owner, along with all maintenance, adjustments, cleaning, and ice purchases. Labor covered under this warranty must be performed by a COMPANY Contracted Service Representative or a refrigeration service agency as qualified and authorized by the COMPANY'S local Distributor. The COMPANY'S liability under this warranty shall in no event be greater than the actual purchase price paid by customer for the ice machine.



The foregoing warranty shall not apply to (1) any part or assembly that has been altered, modified, or changed; (2) any part or assembly that has been subjected to misuse, abuse, neglect, or accidents; (3) any ice machine that has been installed and/or maintained inconsistent with the technical instructions provided by the COMPANY; or (4) any ice machine initially installed more than five years from the serial number production date. This warranty shall not apply if the Ice Machine's refrigeration system is modified with a condenser, heat reclaim device, or parts and assemblies other than those manufactured by the COMPANY, unless the COMPANY approves these modifications for specific locations in writing.

**THIS WARRANTY IS IN LIEU OF ALL OTHER WARRANTIES OR GUARANTEES OF ANY KIND, EXPRESSED OR IMPLIED, INCLUDING ANY IMPLIED WARRANTY OF MERCHANTABILITY OR FITNESS FOR A PARTICULAR PURPOSE.** In no event shall the COMPANY be liable for any special, indirect, incidental or consequential damages. Upon the expiration of the warranty period, the COMPANY'S liability under this warranty shall terminate. The foregoing warranty shall constitute the sole liability of the COMPANY and the exclusive remedy of the customer or user.

To secure prompt and continuing warranty service, the warranty registration card must be completed and sent to the COMPANY within five (5) days from the installation date.

Complete the following and retain for your record:

Distributor/Dealer

Model Number Serial Number

Installation Date

MANITOWOC ICE

2110 So. 26th St., P.O. Box 1720, Manitowoc, WI 54220

Telephone: 920-682-0161 • Fax: 920-683-7585

Web Site - [www.manitowocice.com](http://www.manitowocice.com)

## **Q Model & S Model Flake/Chiplet/Nugget Residential Warranty**

### WHAT DOES THIS LIMITED WARRANTY COVER?

Subject to the exclusions and limitations below, Manitowoc Ice, Inc. (“Manitowoc”) warrants to the original consumer that any new ice machine manufactured by Manitowoc (the “Product”) shall be free of defects in material or workmanship for the warranty period outlined below under normal use and maintenance, and upon proper installation and start-up in accordance with the instruction manual supplied with the Product.

### HOW LONG DOES THIS LIMITED WARRANTY LAST?

<b>Product Covered</b>	<b>Warranty Period</b>
Ice Machine	Twelve months from the sale date

### WHO IS COVERED BY THIS LIMITED WARRANTY?

This limited warranty only applies to the original consumer of the Product and is not transferable.

## WHAT ARE MANITOWOC ICE'S OBLIGATIONS UNDER THIS LIMITED WARRANTY?

If a defect arises and Manitowoc receives a valid warranty claim prior to the expiration of the warranty period, Manitowoc shall, at its option: (1) repair the Product at Manitowoc's cost, including standard straight time labor charges, (2) replace the Product with one that is new or at least as functionally equivalent as the original, or (3) refund the purchase price for the Product. Replacement parts are warranted for 90 days or the balance of the original warranty period, whichever is longer. The foregoing constitutes Manitowoc's sole obligation and the consumer's exclusive remedy for any breach of this limited warranty. Manitowoc's liability under this limited warranty is limited to the purchase price of Product. Additional expenses including, without limitation, service travel time, overtime or premium labor charges, accessing or removing the Product, or shipping are the responsibility of the consumer.

## HOW TO OBTAIN WARRANTY SERVICE

To obtain warranty service or information regarding your Product, please contact us at:

MANITOWOC ICE

2110 So. 26th St. P.O. Box 1720, Manitowoc, WI  
54221-1720

Telephone: 920-682-0161    Fax: 920-683-7585

[www.manitowocice.com](http://www.manitowocice.com)

## WHAT IS NOT COVERED?

This limited warranty does not cover, and you are solely responsible for the costs of: (1) periodic or routine maintenance, (2) repair or replacement of the Product or parts due to normal wear and tear, (3) defects or damage to the Product or parts resulting from misuse, abuse, neglect, or accidents, (4) defects or damage to the Product or parts resulting from improper or unauthorized alterations, modifications, or changes; and (5) defects or damage to any Product that has not been installed and/or maintained in accordance with the instruction manual or technical instructions provided by Manitowoc. To the extent that warranty exclusions are not permitted under some state laws, these exclusions may not apply to you.

EXCEPT AS STATED IN THE FOLLOWING SENTENCE, THIS LIMITED WARRANTY IS THE SOLE AND EXCLUSIVE WARRANTY OF MANITOWOC WITH REGARD TO THE PRODUCT. ALL IMPLIED WARRANTIES ARE STRICTLY LIMITED TO THE DURATION OF THE LIMITED WARRANTY APPLICABLE TO THE PRODUCTS AS STATED ABOVE, INCLUDING BUT NOT LIMITED TO, ANY WARRANTY OF MERCHANTABILITY OR OF FITNESS FOR A PARTICULAR PURPOSE.

Some states do not allow limitations on how long an implied warranty lasts, so the above limitation may not apply to you.

IN NO EVENT SHALL MANITOWOC OR ANY OF ITS AFFILIATES BE LIABLE TO THE CONSUMER OR ANY OTHER PERSON FOR ANY INCIDENTAL, CONSEQUENTIAL OR SPECIAL DAMAGES OF ANY KIND (INCLUDING, WITHOUT LIMITATION, LOSS OF PROFITS, REVENUE OR BUSINESS) ARISING FROM OR IN ANY MANNER CONNECTED WITH THE PRODUCT, ANY BREACH OF THIS LIMITED WARRANTY, OR ANY OTHER CAUSE WHATSOEVER, WHETHER BASED ON CONTRACT, TORT OR ANY OTHER THEORY OF LIABILITY.

Some states do not allow the exclusion or limitation of incidental or consequential damages, so the above limitation or exclusion may not apply to you.

#### HOW STATE LAW APPLIES

This limited warranty gives you specific legal rights, and you may also have rights that vary from state to state or from one jurisdiction to another.

#### REGISTRATION CARD

To secure prompt and continuing warranty service, this warranty registration card must be completed and sent to Manitowoc within thirty (30) days from the sale date. Complete the registration card and send it to Manitowoc.

**This Page Intentionally Left Blank**

# Installation



## Warning

### PERSONAL INJURY POTENTIAL

Remove all ice machine panels before lifting and installing.

## Location of Ice Machine

The location selected for the ice machine must meet the following criteria. If any of these criteria are not met, select another location.

- The location must be indoors.
- The location must be free of airborne and other contaminants.
- The air temperature must be at least 45°F (7°C), but must not exceed 110°F (43°C).
- The water temperature must be at least 45°F (7°C), but must not exceed 90°F (32°C).
- The location must not be near heat-generating equipment or in direct sunlight.
- The location must be capable of supporting the weight of the ice machine and a full bin of ice.
- The location must allow enough clearance for water, drain and electrical connections in the **rear of the ice machine**.
- The location must not obstruct airflow through or around the ice machine. Refer to the chart below for clearance requirements.
- RFC Condensing Units ONLY - Interconnecting wiring (115/60/1 or 230/50/1) is required between the ice machine and condensing unit to energize the contactor coil.
- The ice machine must be protected if it will be subjected to temperatures below 32°F (0°C). Failure caused by exposure to freezing temperatures is not covered by the warranty. See "Removal from Service/Winterization"

## Ice Machine Clearance Requirements

<b>SN12/SN20</b>	<b>Self-Contained Air-Cooled</b>	<b>Water-Cooled*</b>
Top	24" (61.0 cm)	NA
Sides	8" (20.3 cm)	NA
Back	5" (12.7 cm)	NA

<b>QF400</b>	<b>Self-Contained Air-Cooled</b>	<b>Water-Cooled and Remote*</b>
Top/Sides	5" (12.7 cm)	NA
Back	5" (12.7 cm)	NA

<b>SF400/SN450 SF600/SN650 SF900/SN950 S1200/SN1250</b>	<b>Self-Contained Air-Cooled</b>	<b>Water-Cooled and Remote*</b>
Top/Sides	8" (20.3 cm)	8" (20.3 cm)*
Back	5" (12.7 cm)	5" (12.7 cm)*

<b>QF800 QC700</b>	<b>Self-Contained Air-Cooled</b>	<b>Water-Cooled and Remote*</b>
Top/Sides	8" (20.3 cm)	5" (12.7 cm)*
Back	5" (12.7 cm)	5" (12.7 cm)*

<b>QF2200 QF2300</b>	<b>Self-Contained Air-Cooled</b>	<b>Water-Cooled and Remote*</b>
Top/Sides	NA	5" (12.7 cm)*
Back	NA	5" (12.7 cm)*

\* Water-Cooled and Remotes Only - There is no minimum clearance required. This value is recommended for efficient operation and servicing only.

NOTE: SN12/SN20 airflow is in the left side and out the top.  
QF400 is in and out the front of the ice machine.



## Ice Machine Heat of Rejection

Series Ice Machine	Heat of Rejection*
	Air Conditioning
SN12/SN20	2,300
QF400	4,000
SF400/SN450	3,400
SF600/SN650	5,300
QF800/QC700	7,800
SF900/SN950 SF900C/SN950C	9,000
SF1200/SN1250 SF1200C/SN1250C	16,000
QF2200/QF2300	21,000
* BTU/Hour Because the heat of rejection varies during the ice making cycle, the figure shown is an average.	

Ice machines, like other refrigeration equipment, reject heat through the condenser. It is helpful to know the amount of heat rejected by the ice machine when sizing air conditioning equipment where self-contained air-cooled ice machines are installed.

This information is also necessary when evaluating the benefits of using water-cooled or remote condensers to reduce air conditioning loads. The amount of heat added to an air conditioned environment by an ice machine using a water-cooled or remote condenser is negligible.

Knowing the amount of heat rejected is also important when sizing a cooling tower for a water-cooled condenser. Use the peak figure for sizing the cooling tower.

## Location of Traditional Remote Units and Remote condensing units

The location selected for the Remote Units must meet the following criteria. If any of these criteria are not met, select another location.

- The air temperature must be at least -20°F (-28.9°C) but must not exceed 120°F (49°C).
- The location must not allow exhaust fan heat and/or grease to enter the condenser.
- The location must not obstruct airflow through or around the condensing unit. Refer to the chart below for clearance requirements.
- **RFC Condensing Units ONLY** - Interconnecting wiring (115/60/1) is required between the ice machine and condensing unit to energize the contactor coil.

Traditional Remote/Condensing Unit Clearances	
Traditional Remote JC0495 Top/Bottom	Bottom clearance is 12" (31 cm) Top clearance is 4' (1.2 m)
Traditional Remote JC0495 Sides	There is no minimum clearance required, although 6" (15 cm) is recommended for efficient operation and servicing only.
Remote Condensing Unit RFC - Top/Sides	There is no minimum clearance required, although 6" (15 cm) is recommended for efficient operation and servicing only.
Remote Condensing Unit RFC - Front/Back	4' (1.2 m)

# Electrical Service

## General



### Warning

All wiring must conform to local, state and national codes.

## Voltage

The maximum allowable voltage variation is  $\pm 10\%$  of the rated voltage on the ice machine model/serial number plate at start-up (when the electrical load is highest).

## Fuse/Circuit Breaker

A separate fuse/circuit breaker must be provided for each ice machine. Circuit breakers must be H.A.C.R. rated (does not apply in Canada).



### Warning

The ice machine must be grounded in accordance with national and local electrical codes.

**SN012/SN020/QF0400 115/60/1 ice machines** are factory pre-wired with a power cord and 5-15P plug confirmation.

**SN012/SN020/QF0400 230/50/1 ice machines** are factory pre-wired with a power cord, no plug is supplied.

**SF0400/SN0450/SF0600/SN0650/SF0900/SN0950/SF1200/SN1250** ice machines are not supplied with a power cord.

**SF0900C/SN0950C/SF1200C/SN1250C/QF2200/QF2300 with Remote Condensing Unit** the ice machine head section and remote condensing unit are wired independent of each other. A separate dedicated fuse/circuit breaker must be provided for each condensing unit. Circuit breakers must be H.A.C.R. rated (does not apply in Canada).

## CIRCUIT AMPACITY

The minimum circuit ampacity is used to help select the wire size of the electrical supply. (Minimum circuit ampacity is not the ice machine's running amp load.)

The wire size (or gauge) is also dependent upon location, materials used, length of run, etc., so it must be determined by a qualified electrician.

<b>Self Contained Air-Cooled</b>			
<b>Ice Machine</b>	<b>Voltage Phase Cycle</b>	<b>Max. Fuse/Circuit Breaker</b>	<b>Total Amps</b>
SN012 SN020	115/1/60	15	10.3
	230/1/50	15	4.6
QF0400	115/1/60	15	9.8
	230/1/50	15	4.2

<b>Ice Machine</b>	<b>Voltage Phase Cycle</b>	<b>Max. Fuse/Circuit Breaker</b>	<b>Minimum Circuit Amps</b>
SF0400/ SN0450	<b>Air-Cooled</b>		
	115/1/60	20	13.7
	230/1/50	15	7.2
	<b>Water-Cooled</b>		
	115/1/60	20	12.9
	230/1/50	15	6.6
SF0600/ SN0650	<b>Air-Cooled</b>		
	115/1/60	20	16.2
	230/1/50	15	7.0
	<b>Water-Cooled</b>		
	115/1/60	20	15.5
	230/1/50	15	6.7
JC0495	<b>Remote Air-Cooled</b>		
	115/1/60	20	17.9
JC0495	<b>Traditional Remote Condenser</b>		
	115/60/1	NA	2.3

<b>Ice Machine</b>	<b>Voltage Phase Cycle</b>	<b>Max. Fuse/ Circuit Breaker</b>	<b>Minimum Circuit Amps</b>
QC0700/ QF0800	<b>Air-Cooled</b>		
	115/1/60	30	18.9
	230/1/50	20	8.8
	230/1/60	15	8.7
	<b>Water-Cooled</b>		
	115/1/60	30	17.9
	230/1/50	20	8.4
	230/1/60	15	8.3
SF0900/ SN0950	<b>Air-Cooled</b>		
	230/1/50	15	7.0
	230/1/60	15	8.0
	<b>Water-Cooled</b>		
	230/1/50	15	6.7
	230/1/60	15	7.7
SF0900C/ SN0950C	<b>Air-Cooled Head Section</b>		
	115/1/60	15	1.7
SF1200/ SN1250	<b>Air-Cooled</b>		
	230/1/50	15	8.0
	230/1/60	15	9.8
	<b>Water-Cooled</b>		
	230/1/50	15	7.7
	230/1/60	15	9.0
SF1200C/ SN1250C	<b>Air-Cooled Head Section</b>		
	115/1/60	15	2.1
QF2200	<b>Remote Air-Cooled Head Section</b>		
	115/1/60	15	4.3
QF2300	<b>Remote Air-Cooled Head Section</b>		
	115/1/60	15	5.5

<b>Condensing Unit</b>	<b>Voltage Phase Cycle</b>	<b>Max. Fuse/ Circuit Breaker</b>	<b>Minimum Circuit Amps</b>
<b>RFC0985</b> used with <b>SF0900C/</b> <b>SN0950C</b>	<b>Remote Condensing Unit</b>		
	208-230/1/60	15	8.6
	208-230/1/50	15	8.0
<b>RFC1285</b> used with <b>SF1200C/</b> <b>SN1250C</b>	<b>Remote Condensing Unit</b>		
	208-230/1/60	15	9.2
	208-230/3/60	15	6.8
	208-230/1/50	15	12.0
<b>RFC2085</b> used with <b>QF2200</b>	<b>Remote Condensing Unit</b>		
	208-230/1/60	30	15.6
	208-230/3/60	20	11.2
<b>RFC2385</b> used with <b>QF2300</b>	<b>Remote Condensing Unit</b>		
	208-230/1/60	30	18.5
	208-230/3/60	20	12.8

# Ice Machine Head Section Water Supply and Drains

## POTABLE WATER SUPPLY

Local water conditions may require treatment of the water to inhibit scale formation, filter sediment, remove chlorine, and improve taste and clarity.

### **Important**

If you are installing a Manitowoc water filter system, refer to the Installation Instructions supplied with the filter system for ice making water inlet connections.

## POTABLE WATER INLET LINES

Follow these guidelines to install water inlet lines:

- Do not connect the ice machine to a hot water supply. Be sure all hot water restrictors installed for other equipment are working. (Check valves on sink faucets, dishwashers, etc.)
- If water pressure exceeds the maximum recommended pressure of 80 psig (5.5 Bar), obtain a water pressure regulator from your Manitowoc Distributor.
- Install a water shut-off valve and union for both the ice making and condenser water lines.
- Insulate water inlet lines to prevent condensation.

## **DRAIN CONNECTIONS**

Follow these guidelines when installing drain lines to prevent drain water from flowing back into the ice machine and storage bin:

- Drain lines must have a 1.5 in. (3.8 cm) drop per 5 ft. of run (2.5 cm per meter), and must not create traps.
- The floor drain must be large enough to accommodate drainage from all drains.
- Run separate bin and water-cooled condenser drain lines. Insulate them to prevent condensation.
- Vent the bin drain to the atmosphere. Do not vent the condenser drain on water-cooled models.
- Drains must have a union or other suitable means to allow a place of disconnection from the ice machine when servicing is required.

## **COOLING TOWER APPLICATIONS (WATER-COOLED MODELS)**

A water cooling tower installation does not require modification of the ice machine. The water regulator valve for the condenser continues to control the refrigeration discharge pressure.

It is necessary to know the amount of heat rejection, (refer to page 25) and the pressure drop through the condenser and water valves (inlet and outlet) when using a cooling tower on an ice machine.

- Water entering the condenser must not exceed 90°F (32°C).
- Water flow through the condenser must not exceed 5 gal. (19 L) per minute.
- Allow for a pressure drop of 7 psi (48 kPa) between the condenser water inlet and the outlet of the ice machine.
- Water exiting the condenser must not exceed 110°F (43°C).



## INSTALLING ON A DISPENSER

Nugget ice is soft and chewable. This characteristic makes this ice more difficult to dispense. All dispenser manufacturers require a kit be installed for Nugget type ice. Contact the dispenser manufacturer for the correct adapter and nugget dispensing kit for your specific model dispenser. The required kit can vary by dispenser size from the same manufacturer.

Failure to install the correct kit and make the necessary modifications on the dispenser will result in:

- Congealed ice which will not dispense and will damage the ice machine and dispenser
- Insufficient ice contact with the cold plate which will result in an inferior product
- A safety issue if ice lifts the adapter or ice machine

### Nugget Dispensing Kit Installation Procedure

1. Follow the dispenser manufacturers instructions for installation of the adapter (if required) and nugget ice kit.
2. Make all necessary beverage, electrical and drain connections to the dispenser.
3. Level the dispenser front to back and side to side.
4. Install ice machine on dispenser and secure ice machine, dispenser and adapter with provided brackets.
5. Complete water, drain and electrical connections to the ice machine.



### Warning

#### PERSONAL INJURY POTENTIAL

The ice machine and adapter must be attached to the dispenser to prevent the ice machine from falling.



### Caution

Ice machines in low volume locations may experience congealing. Thermostat kit K00364 must be added in these locations to prevent damage to the ice machine and dispenser.

## LINE SET REQUIREMENTS

### Traditional Remote Units Only

Ice Machine Head Section	Condenser	Line Set
SN0650	JC0495	RM-20 RM-35 RM-50

Line Set	Discharge Line	Liquid Line	Insulation Thickness
RM20/35/50	5/16 in (7.9 mm)	1/4 in (7 mm)	1/2 in 12.7 mm

### QuietQube Remote Condensing Units Only

Ice Machine Head Section	Condensing Unit	Line Set
SF0900C SN0950C	RFC0985	RC-21 RC-31 RC-51
SF1200C SN1250C	RFC1285	RC-21 RC-31 RC-51
QF2200/QF2300	RFC2085 RFC2385	RC-20 RC-30 RC-50

Line Set	Suction Line	Liquid Line	Insulation Thickness
RC-21 RC-31 RC-51	5/8 in (15.9 mm)	3/8 in (9.5 mm)	1/2 in (12.7 mm)
RC-20 RC-30 RC-50	3/4 in. (19.1 mm)	1/2 in. (12.7 mm)	Suction Line 1/2" (13 mm)  Liquid Line 1/4" (7 mm)

- Maximum total amount of tubing is 100' (30.5 M)
- Maximum height condenser or condensing unit can be above ice machine is 35' (10.7 M)
- Maximum distance condenser or condensing unit can be below the ice machine 15' (4.5 M)
- Condensing units only - Suction line oil trap is required for any rise that is 20' (6 M) or greater.
- Refer to Installation Use and Care Manual for complete installation information.

### **Important**

**Manitowoc remote systems are only approved and warranted as a complete new package. Warranty on the refrigeration system will be void if a new ice machine head section is connected to pre-existing (used) tubing or remote condensers.**

**This Page Intentionally Left Blank**

# Component Identification

## QF400 Air-cooled

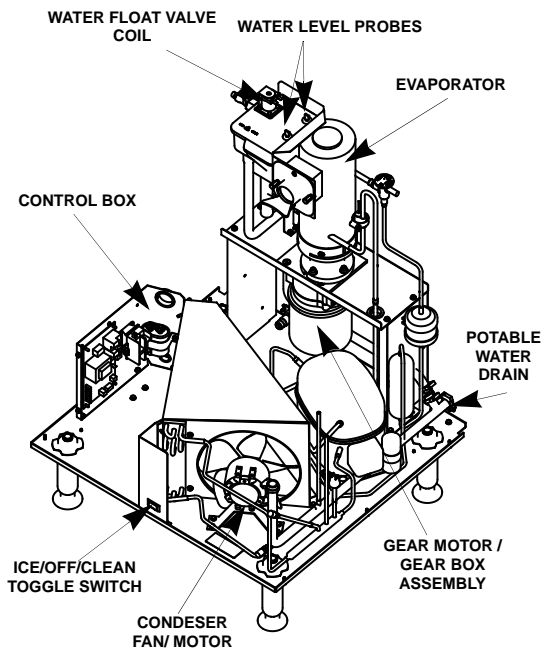

## QF800/QC700 Air & Water-cooled

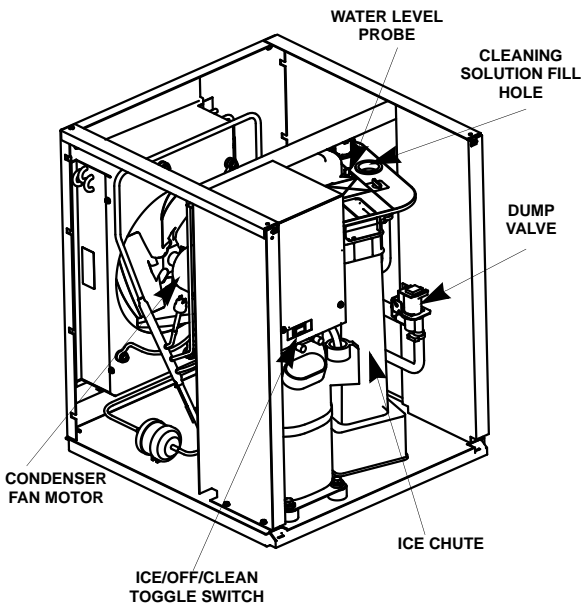

# SF0400/SN0450/SF0600/SN0650/SF0900/ SN0950/SF1200/SN1250 Air & Water- cooled

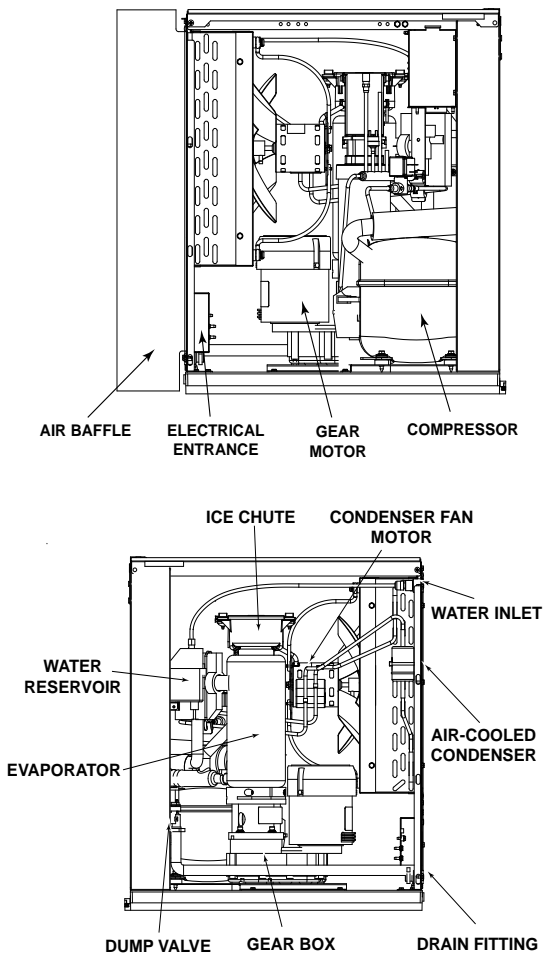

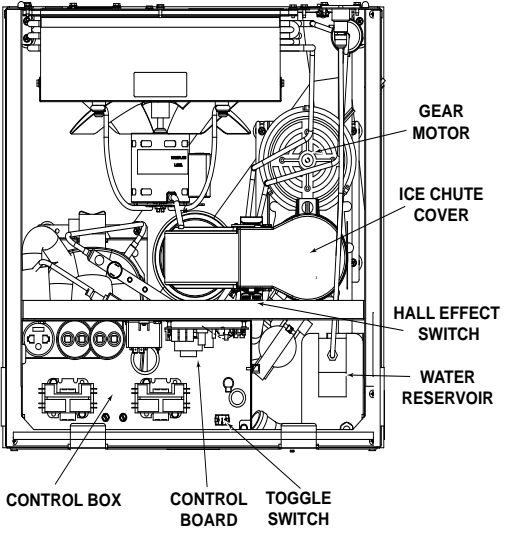



# SF0600/SN0650/SF0900/SN0950/SF1200/ SN1250 Remote & QuietQube Model

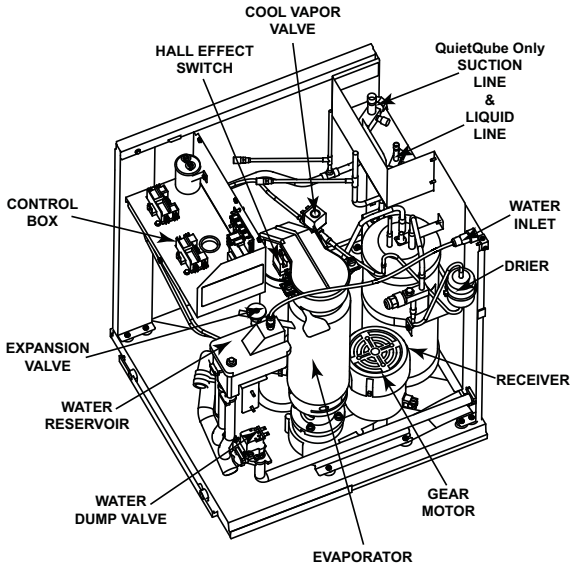

**This Page Intentionally Left Blank**

## Maintenance

---

Maintenance procedures or failures due to a lack of maintenance are not covered by the warranty.

Manitowoc Ice Machine Cleaner and Sanitizer are the only products approved for use in Manitowoc ice machines.

### **Caution**

Use the correct Manitowoc approved metal safe Ice Machine Cleaner (part number **000000084**) and Sanitizer (part number 94-0565-3). It is a violation of Federal law to use these solutions in a manner inconsistent with their labeling. Read and understand all labels printed on bottles before use.

### **Caution**

Do not mix Cleaner and Sanitizer solutions together. It is a violation of Federal law to use these solutions in a manner inconsistent with their labeling.

### **Warning**

Wear rubber gloves and safety goggles (and/or face shield) when handling ice machine Cleaner or Sanitizer.

### **Warning**

If you do not understand the procedures or the safety precautions that must be followed, call your local Manitowoc Distributor or Manitowoc Ice.

## **Manitowoc's Cleaning Technology**

Manitowoc Flake/Nugget Ice Machines allow the initiation and completion of a cleaning cycle at the flip of a switch. This cycle will permit cleaning of all surfaces that come in contact with the water distribution system. Periodic maintenance must be performed that includes sanitizing the bin and adjacent surface areas, which are not contacted by the water distribution system.

Depending on local water conditions Manitowoc recommends initiating preventative maintenance cleaning procedures between the 6 month cleanings. This preventive maintenance removes mineral build-up from the evaporator, which results in peak efficiency and lower operating costs.

This technology allows initiation and completion of a clean cycle, after which the ice machine automatically starts ice making again.

There are three separate cleaning procedures.

### **Heavily Scaled Cleaning Procedure**

Perform this procedure if you have some or all of these symptoms.

- Grinding, popping or squealing noises from the evaporator.
- Grinding noise from gearbox.
- Ice machine trips speed sensor.

A Cleaning/Sanitizing Procedure must be performed after this procedure.

### **Cleaning/Sanitizing Procedure**

This procedure must be performed a minimum of once every six months:

- All ice must be removed from the bin/dispenser.
- The ice machine and bin/dispenser must be disassembled, cleaned and sanitized.
- The ice machine produces ice with the cleaner and sanitizer solutions.
- All ice produced during the cleaning and sanitizing procedure must be discarded

## **Preventative Maintenance Cleaning Procedure**

Perform this procedure as often as required for your water conditions:

- Allows cleaning the ice machine without removing all of the ice from the bin/dispenser.
- Removes mineral deposits from areas that are in direct contact with water during the Freeze cycle (reservoir, evaporator, auger, drain lines).

## **EXTERIOR CLEANING**

Clean the area around the ice machine as often as necessary to maintain cleanliness and efficient operation. Use cleaners designed for use with stainless steel products.

Sponge any dust and dirt off the outside of the ice machine with mild soap and water. Wipe dry with a clean, soft cloth.

Heavy stains should be removed with stainless steel wool. Never use plain steel wool or abrasive pads. They will scratch the panels.

## **SN012/SN020 Only**

### WEEKLY

Remove grill from scrap ice tray and wipe splash panel, scrap ice tray and grill with sanitizer & water solution. Pour excess solution in scrap ice tray to clear drain.

### TOUCHLESS SENSOR ONLY

Wipe sensor window with a soft cloth and mild detergent. Rinse with clear water and dry with a clean soft cloth.

Dust and dirt can be removed from exterior surfaces with mild household dish-washing detergent and warm water. Wipe dry with a clean, soft cloth.

# Preventative Maintenance Procedure

## QF0400

### Preventative Maintenance Cleaning Procedure

**Step 1** Set the toggle switch to the OFF position. Open bin door and remove the 2 thumbscrews and back evaporator panel.

**Step 2** To start a cleaning cycle, move the toggle switch to the CLEAN position. Water will flow through the water dump valve and down the drain. The flush, gear motor, speed, dump valve and water solenoid lights will energize to indicate the ice machine is in the cleaning mode.

**Step 3** Wait about 1 minute or until the dump valve light de-energizes. Lift the front cover on the reservoir and add the proper amount of Manitowoc Ice Machine Cleaner.

### **Caution**

Use Manitowoc clear (P/N 000000084) Ice Machine Cleaner only. It is a violation of Federal law to use these solutions in a manner inconsistent with their labeling. Read and understand all labels printed on bottles before use.

Model	Amount of Cleaner Part Number 000000084
QF0400	2 oz. (60 ml)

**Step 4** The ice machine will automatically time out four Flush and Rinse cycles, and then stop. The Flush light remains energized until the toggle switch is moved to the OFF position. This entire cycle lasts approximately 11 minutes.

**NOTE:** Periodic cleaning must be performed on adjacent surface areas not contacted by the water distribution system.

Manitowoc recommends disassembling, cleaning and sanitizing the ice machine and bin/dispenser a minimum of once every six months.

**Step 5**

- A. The ice machine may be set to start and finish a cleaning procedure, and then automatically start ice making again.
- B. Wait about one minute into the cleaning cycle (until the Dump Valve light de-energizes), then move the switch from CLEAN to ICE position.

When the cleaning cycle is complete, the Flush light will turn off and ice making will start automatically.

## QC0700/QF0800/QF2200/QF2300

### Preventative Maintenance Cleaning Procedure

**Step 1** Remove front and top covers and set the toggle switch to the OFF position.

**Step 2** To start a cleaning cycle, move the toggle switch to the CLEAN position. Water will flow through the water dump valve and down the drain. The flush, gear motor, speed, dump valve and water solenoid lights will energize to indicate the ice machine is in the cleaning mode.

**Step 3** Remove the 1-1/2 in. plug from the top cover of the water reservoir. Wait about one minute or until the Dump Valve light de-energizes, then add the proper amount of Manitowoc Ice Machine Cleaner and reinstall the plug.

#### **Caution**

Use Manitowoc clear (P/N 000000084) Ice Machine Cleaner only. It is a violation of Federal law to use these solutions in a manner inconsistent with their labeling. Read and understand all labels printed on bottles before use.

<b>Model</b>	<b>Amount of Cleaner (Part # 000000084)</b>
QF0800/QC0700	3 oz. (90 ml)
QF2200/QF2300	3 oz. (90 ml)

**Step 4** The ice machine will automatically time out four Flush and Rinse cycles, and then stop. The Flush light remains energized until the toggle switch is moved to the OFF position. This entire cycle lasts approximately 11 minutes.



**NOTE:** Periodic cleaning must be performed on adjacent surface areas not contacted by the water distribution system.

Manitowoc recommends disassembling, cleaning and sanitizing the ice machine and bin/dispenser a minimum of once every six months.

### **Step 5**

- A. The ice machine may be set to start and finish a cleaning procedure, and then automatically start ice making again.
- B. Wait about one minute into the cleaning cycle (until the Dump Valve light de-energizes), then move the switch from CLEAN to ICE position.
- C. When the cleaning cycle is complete, the Flush light will turn off and ice making will start automatically.

## **SN012/SN020/SF0400/SN0450/SF0600/SN0650/ SF0900/SN0950/SF1200/SN1250**

### **Preventative Maintenance**

Ice machine cleaner is used to remove lime scale or other mineral deposits. It is not used to remove algae or slime. Refer to “Sanitizing Procedure” for removal of algae and slime. To initiate a cleaning cycle using Manitowoc’s Cleaning Technology use the following procedure.

**Step 1** To start a cleaning cycle, move the toggle switch to the CLEAN position. Water will flow through the water dump valve and down the drain.

**Step 2** Remove the cover from the top of the ice chute. Wait about one minute then add the proper amount of Manitowoc Ice Machine Cleaner and re-install cover.

### **Caution**

Use only Manitowoc approved Ice Machine Cleaner part number 000000084. It is a violation of Federal law to use these solutions in a manner inconsistent with their labeling. Read and understand all labels printed on bottles before use.

<b>Model</b>	<b>Amount of Cleaner Part Number 000000084</b>
<b>SN12 SN20</b>	<b>2 ounces (60 ml)</b>
<b>SF0400 SN0450</b>	<b>2 ounces (60 ml)</b>
<b>SF0600 SN0650</b>	<b>3 ounces (90 ml)</b>
<b>SF0900 SN0950</b>	<b>6 ounces (180 ml)</b>
<b>SF1200 SN1250</b>	<b>8 ounces (240 ml)</b>
<b>SF2000 SN2050</b>	<b>12 ounces (360 ml)</b>

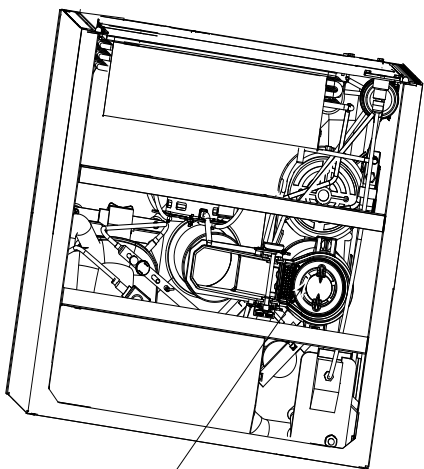

**ADD SOLUTION HERE**

**Step 3** The ice machine will automatically time out a series of flush and rinse cycles, and then stops. This entire cycle lasts approximately 30 minutes.

NOTE: Periodic cleaning must be performed on adjacent surface areas not contacted by the water distribution system.

NOTE: The ice machine may be set to start and finish a cleaning procedure, and then automatically start ice making again.

- A. After cleaner is added move the switch from CLEAN to ICE position.
- B. When the cleaning cycle is complete ice making will start automatically.

## **Changing toggle switch position during clean cycle:**

1. Less than 60 seconds into Clean cycle - The Clean cycle will end when the toggle switch is moved to the OFF position.
  2. More than 60 seconds into Clean cycle - The ice machine will complete the clean cycle. Toggle switch position will determine the next cycle after the Clean cycle is completed.
- CLEAN POSITION - The ice machine will wait for a change in toggle switch position.
  - OFF POSITION - The ice machine will wait for a change in toggle switch position.
  - ICE POSITION - The ice machine will start making ice automatically.
3. To abort the clean cycle move the toggle switch from CLEAN to OFF to CLEAN and back to OFF within a 15 second time period.

Manitowoc recommends disassembling, cleaning and sanitizing the ice machine and dispenser every six months.

## Heavily Scaled Procedure

### QF0400

#### Procedure to Clean Heavily Scaled Ice Machines

**Step 1** Remove all ice from the bin.

**Step 2** Remove front and top covers and set the toggle switch to the OFF position.

**Step 3** Disconnect water supply line at float valve quick disconnect by depressing stainless steel lever.

**Step 4** Refer to chart below:

**Pre-mix cleaner with lukewarm water in a non-metallic container.**

Model	Water Reservoir Capacity	Amount of Cleaner Part Number 000000084	
		Cleaner	Water
QF0400	48 oz (1.4 L)	32 oz (0.94 L)	16 oz (0.5 L)

**Step 5** Remove all water from the evaporator and water reservoir. Start an ice making cycle by moving the toggle switch to the ICE position. Water will flow through the water dump valve and down the drain for 45 seconds. After 45 seconds move the toggle switch to the OFF position. Remove the plug from the top cover of the water reservoir. Add the entire cleaner/water solution and re-install the plug. **Leave the cleaner/water solution in the evaporator for a minimum of 4 hours.**

**Step 6** Move the toggle switch from OFF to ICE. The cleaner/water solution will flow through the water dump valve and down the drain for 45 seconds.

**Step 7** Move the toggle switch to the OFF position, then follow the standard cleaning and sanitizing procedures for the model ice machine you are cleaning.

## QC0700/QF0800/QF2200/QF2300

### Procedure to Clean Heavily Scaled Ice Machines

**Step 1** Remove all ice from the bin.

**Step 2** Remove front and top covers and set the toggle switch to the OFF position.

**Step 3** Disconnect water supply line at float valve quick disconnect by depressing stainless steel lever.

**Step 4** Refer to chart below:

**Premix cleaner with lukewarm water in a non-metallic container.**

Model	Water Reservoir Capacity	Amount of Cleaner Part Number 000000084	
		Cleaner	Water
QF0800/ QC0700	48 oz (1.4 L)	32 oz (0.94 L)	16 oz (0.5 L)
QF2200/ QF2300	72 oz (2.1 L)	48 oz (1.4 L)	24 oz (0.7 L)

**Step 5** Remove all water from the evaporator and water reservoir. Start an ice making cycle by moving the toggle switch to the ICE position. Water will flow through the water dump valve and down the drain for 45 seconds. After 45 seconds move the toggle switch to the OFF position. Remove the plug from the top cover of the water reservoir. Add the entire cleaner/water solution and re-install the plug. **Leave the cleaner/water solution in the evaporator for a minimum of 4 hours.**

**Step 6** Move the toggle switch from OFF to ICE. The cleaner/water solution will flow through the water dump valve and down the drain for 45 seconds.

Move the toggle switch to the OFF position, then follow the standard cleaning and sanitizing procedures for the model ice machine you are cleaning.

**SN012/SN020/SF0400/SN0450/SF0600/SN0650/  
SF0900/SN0950/SF1200/SN1250**

**Procedure to Clean Heavily Scaled Flake/Nugget  
Ice Machines**

Ice machines that are heavily scaled or have not been cleaned on a regular basis will need to run this Procedure. Failure to do so may result in binding of the auger as the lime scale releases from the auger and evaporator barrel.

**Step 1** Remove panels and set the ICE/OFF/CLEAN toggle switch to the OFF position.

**Step 2** Remove all ice from the bin.

**Step 3** Turn off the water supply to the ice machine.

**Step 4** Place ICE/OFF/CLEAN toggle switch in the CLEAN position. The dump valve will open and drain the water from the evaporator and reservoir.

**Step 5** Wait approximately 30 seconds (or until the evaporator is drained) and place the toggle switch in the OFF position.

**Step 6** Refer to chart and add the correct amount of cleaner for your model ice machine.

<b>Model</b>	<b>Amount of Cleaner Part Number 000000084</b>
SN12 SN20	16 ounces (473 ml)
SF0400 SN0450	
SF0600 SN0650	
SF0900 SN0950	
SF1200 SN1250	32 ounces (950 ml)
SF2000 SN2050	

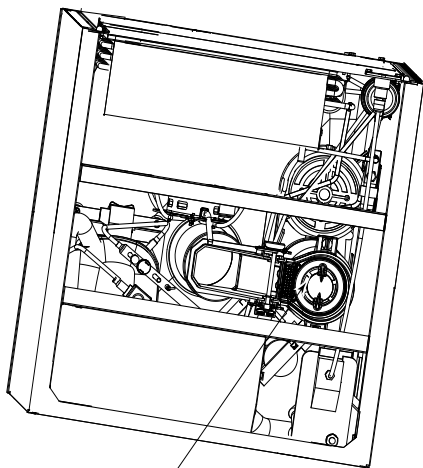

**ADD SOLUTION HERE**

**Step 1** Turn on the water supply to the ice machine.

### **Important**

Leave the cleaner/water solution in the evaporator for a minimum of 4 hours.

**Step 2** Move the toggle switch to the ICE position. The compressor will energize and produce ice with the cleaning solution. Continue the freeze cycle for 15 minutes.

**Step 3** Move the toggle switch to the OFF position, then follow the standard cleaning and sanitizing procedures.



# Cleaning And Sanitizing Procedure

## QF0400

### Cleaning and Sanitizing Procedure

**Step 1** Set the toggle switch to the OFF position. Open bin door and remove the 2 thumbscrews and back evaporator panel.

**Step 2** To start a cleaning cycle, move the toggle switch to the CLEAN position. Water will flow through the water dump valve and down the drain. The flush, gear motor, speed, dump valve and water solenoid lights will energize to indicate the ice machine is in the cleaning mode.

**Step 3** Wait about 1 minute or until the dump valve light de-energizes. Lift the front cover on the reservoir and add the proper amount of Manitowoc Ice Machine Cleaner.

Model	Amount of Cleaner Part Number 000000084
QF0400	2 oz. (60 ml)

**Step 4** The ice machine will automatically time out four Flush and Rinse cycles, and then stop. The Flush light remains energized until the toggle switch is moved to the OFF position. This entire cycle lasts approximately 11 minutes.

NOTE: The ice machine may be set to start and finish a cleaning procedure, and then automatically start ice making again.

- A. Wait about one minute into the cleaning cycle (until the Dump Valve light de-energizes), then move the switch from CLEAN to ICE position.
- B. When the cleaning cycle is complete, the Flush light will turn off and ice making will start automatically.

**Step 5** Disconnect water supply line at float valve quick disconnect by depressing stainless steel lever.

**Step 6** Mix 2 oz. (60 ml) of Manitowoc Ice Machine Sanitizer with 3 gal. (11 L) of cool water.

Model	Amount of Sanitizer/Water
QF0400	2 oz. (60 ml) mixed with 3 gal. (11 L) cool water

**Step 7** To start the sanitizing procedure, move the toggle switch to the ICE position. The gear motor will start and the water dump valve will energize. Water will flow through the water dump valve and down the drain. The control board light for the dump valve, gear motor, and speed will energize to indicate the ice machine is starting the ice making sequence.

**Step 8** Wait 45 seconds until the Dump Valve light de-energizes and the Water Level Probe light energizes. Fill the water reservoir with the pre-mixed solution of sanitizer/water. When water contacts the water level probe, the compressor will energize.

The ice machine will freeze and discharge the sanitizing solution into the bin. Add the remaining sanitizer/water solution when the water level in the reservoir drops.

**NOTE:** Do not allow the water level to drop below the water level probes. The ice machine will discontinue the cycle when the water level probes open (lose water contact) for more than 90 seconds (30 seconds on replacement boards).

**Step 9** After the entire sanitizer/water solution has been added to the reservoir, reconnect the water supply line at the float valve quick disconnect.

The ice machine will continue to freeze and discharge the sanitizing solution into the bin.

Allow the cycle to run for ten minutes to remove all sanitizing solution from the water reservoir.

**Step 10** Place the toggle switch in the OFF position, discard all ice produced and refer to disassembly for cleaning and sanitizing.

## QC0700/QF0800/QF2200/QF2300

### Cleaning and Sanitizing Procedure

**Step 1** Remove front and top cover and set the toggle switch to the OFF position.

**Step 2** Remove all ice from the bin/dispenser.

**Step 3** Disconnect water supply line at float valve quick disconnect by depressing stainless steel lever.

**Step 4** Remove the top cover from the water reservoir.

**Step 5** Remove the water level probes from the top cover and with wires attached, place the water level probes (stand upright) inside the water reservoir.

**Step 6** To start the cleaning procedure, move the toggle switch to the ICE position. The gear motor will start and the water dump valve will energize. Water will flow through the water dump valve and down the drain. The control board light for the dump valve, gear motor, and speed will energize to indicate the ice machine is starting the ice making sequence.

**Step 7** Wait 45 seconds until the Dump Valve light de-energizes and the Water Level Probe light energizes. Add the proper amount of Manitowoc Ice Machine Cleaner to the water reservoir.

Model	Amount of Cleaner Part Number 00000084
QF0800/QC0700	3 oz. (90 ml)
QF2200/QF2300	3 oz. (90 ml)

**Step 8** Reconnect the water supply line to the float valve. When water contacts the water level probe, the compressor will energize. The ice machine will freeze and discharge the cleaning solution into the bin. Continue the Freeze cycle for ten minutes to remove all cleaning solution from the water reservoir.

**Step 9** Discard all ice produced during the cleaning process.

**Step 10** Disconnect water supply line at float valve quick disconnect by depressing stainless steel lever.

**Step 11** Mix 2 oz. (60 ml) of Manitowoc Ice Machine Sanitizer with 3 gal. (11 L) of cool water.

Model	Amount of Sanitizer/Water
QF0800/QC0700/QF2200/ QF2300	2 oz. (60 ml) mixed with 3 gal. (11 L) cool water

**Step 12** To start the sanitizing procedure, move the toggle switch to the ICE position. The gear motor will start and the water dump valve will energize. Water will flow through the water dump valve and down the drain. The control board light for the dump valve, gear motor, and speed will energize to indicate the ice machine is starting the ice making sequence.

**Step 13** Wait 45 seconds until the Dump Valve light de-energizes and the Water Level Probe light energizes. Fill the water reservoir with the pre-mixed solution of sanitizer/water. When water contacts the water level probe, the compressor will energize.

The ice machine will freeze and discharge the sanitizing solution into the bin. Add the remaining sanitizer/water solution when the water level in the reservoir drops.

**NOTE:** Do not allow the water level to drop below the water level probes. The ice machine will discontinue the cycle when the water level probes open (lose water contact) for more than 90 seconds (30 seconds on replacement boards).

**Step 14** After the entire sanitizer/water solution has been added to the reservoir, reconnect the water supply line at the float valve quick disconnect.

The ice machine will continue to freeze and discharge the sanitizing solution into the bin.

Allow the cycle to run for ten minutes to remove all sanitizing solution from the water reservoir.

**Step 15** Place the toggle switch in the OFF position, discard all ice produced and refer to disassembly for cleaning and sanitizing.

**SN012/SN020/SF0400/SN0450/SF0600/SN0650/  
SF0900/SN0950/SF1200/SN1250**

## **Cleaning & Sanitizing Procedure**

Ice machines that are heavily scaled or have not been cleaned on a regular basis will need to run the Heavily Scaled Cleaning Procedure before this one. Failure to do so may result in binding of the auger as the lime scale releases from the auger and evaporator barrel.

Ice machine cleaner is used to remove lime scale or other mineral deposits. Ice machine sanitizer is used to remove algae or slime.

**Step 1** Remove panels and set the ICE/OFF/CLEAN toggle switch to the OFF position.

**Step 2** Turn off the water supply to the ice machine.

**Step 3** Remove all ice from the bin.

**Step 4** Place ICE/OFF/CLEAN toggle switch in the CLEAN position. The dump valve will open and drain the water from the evaporator and reservoir.

**Step 5** Wait approximately 30 seconds (or until the evaporator is drained) and place the toggle switch in the OFF position.

### **Caution**

Use only Manitowoc approved Ice Machine Cleaner part number 000000084. It is a violation of Federal law to use these solutions in a manner inconsistent with their labeling. Read and understand all labels printed on bottles before use.

**Step 6** Refer to chart and premix the correct solution of cleaner and cool water for your model ice machine.

<b>Model</b>	<b>Amount of Cleaner Part Number 000000084</b>	<b>Amount of Water</b>
SN12 SN20	2 oz (60 ml)	32 oz (1 liter)
SF0400 SN0450	2 oz (60 ml)	32 oz (1 liter)
SF0600 SN0650	3 oz (90 ml)	32 oz (1 liter)
SF0900 SN0950	4 oz (120 ml)	32 oz (1 liter)
SF1200 SN1250	8 oz (235 ml)	64 oz (2 liter)
SF2000 SN2050	8 oz (235 ml)	64 oz (2 liter)

**Step 7** Remove the top cover from the ice chute and pour the cleaner/water solution into the evaporator. Add the entire amount of premixed solution (excess solution will exit through the overflow tube in the water reservoir).

**Step 8** Replace the ice chute cover and allow the ice machine to stand for 30 minutes.

**Step 9** Turn on the water supply to the ice machine.

**Step 10** Move the toggle switch to the ICE position. The compressor will energize and produce ice with the cleaning solution.

**Step 11** The ice machine will freeze and discharge the cleaning solution into the bin. Allow the cycle to run for 15 minutes.

**Step 12** Place the toggle switch in the OFF position and discard all ice produced during the cleaning process.

**Step 13** Turn off the water supply to the ice machine.

**Step 14** Place ICE/OFF/CLEAN toggle switch in the CLEAN position. The dump valve will open and drain the water from the evaporator and reservoir.

**Step 15** Wait approximately 30 seconds (or until the evaporator is drained) and place the toggle switch in the OFF position.

**Step 16** Refer to chart and premix the correct solution of sanitizer and cool water for your model ice machine.

Model	Amount of Sanitizer Part Number 94-0565-3	Amount of Water
SN12 SN20	2 ounces (60 ml)	3 gallons (11.4L)
SF0400 SN0450		
SF0600 SN0650		
SF0900 SN0950		
SF1200 SN1250		

**Step 17** Remove the top cover from the ice chute and pour the sanitizer/water solution into the evaporator. Add the entire amount of premixed solution (excess solution will exit through the overflow tube in the water reservoir).

**Step 18** Replace the ice chute cover and allow the ice machine to stand for 30 minutes.

**Step 19** Turn on the water supply to the ice machine.

**Step 20** Move the toggle switch to the ICE position. The compressor will energize and produce ice with the sanitizing solution.

**Step 21** The ice machine will freeze and discharge the sanitizing solution into the bin. Allow the cycle to run for 15 minutes.

**Step 22** Discard all ice produced during the sanitizing process.

**Step 23** Place the toggle switch in the CLEAN position. The ice machine will automatically time out a series of flush and rinse cycles, and then stops. This entire cycle lasts approximately 30 minutes.

**Step 24** Refer to Disassembly For Cleaning/ Sanitizing for your specific model and remove, clean and sanitize all parts listed.



## Component Disassembly For Cleaning And Sanitizing



### Warning

Disconnect electric power to the ice machine at the electric switch box before proceeding.



### Warning

Wear rubber gloves and safety goggles (and/or face shield) when handling Ice Machine Cleaner or Sanitizer.



### Caution

Do not mix Cleaner and Sanitizer solutions together. It is a violation of Federal law to use these solutions in a manner inconsistent with their labeling.

## GENERAL INFORMATION

1. Turn off the water supply to the ice machine at the water service valve, or disconnect water supply line at float valve quick disconnect by depressing stainless steel lever.
2. Remove the components you want to clean or sanitize. See the pages specific to the model you are working on for removal procedures.
3. Soak the removed parts to clean and sanitize.

Solution Type	Water	Mixed With
Cleaner	1 gal. (4 L)	16 oz. (500 ml) cleaner
Sanitizer	3 gal. (11 L)	2 oz. (60 ml) sanitizer

4. Use a soft-bristle brush or sponge (NOT a wire brush) to carefully clean the parts.
5. Use the solution and a brush to clean all disassembled components and the inside of the bin.
6. Re-install the removed parts and turn on the water and electrical supply.

## QF400

### Removal of Parts for Cleaning and Sanitizing

#### Water Level Probe Removal

1. Place the toggle switch in the OFF position, turn off the water supply and disconnect electrical power to the ice machine.
2. Disconnect water supply line at float valve quick disconnect by depressing stainless steel lever.
3. Pull up on water level probes to remove.
4. Disconnect wires from water level probes or control board.

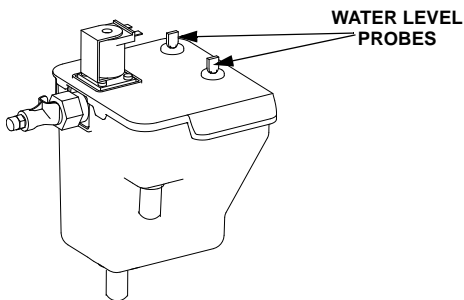

#### Water Reservoir Cover Removal

1. Place the toggle switch in the OFF position, turn off the water supply and disconnect electrical power to the ice machine.
2. Remove water level probes.
3. Remove water float valve coil.
4. Depress coil and rotate 1/4 turn counterclockwise.
5. With coil wires attached, lift coil off enclosure tube.
6. Remove top cover from float reservoir.

## **Float Valve Removal**

1. Place the toggle switch in the OFF position, turn off the water supply and disconnect electrical power to the ice machine.
2. Disconnect water supply line at float valve quick disconnect by depressing stainless steel lever.
3. Remove water float valve coil.
4. Depress coil and rotate 1/4 turn counterclockwise.
5. With coil wires attached, lift coil off enclosure tube.
6. Remove top cover from float reservoir.
7. Lift float valve out of float reservoir.

## **Water Reservoir Removal**

1. Place the toggle switch in the OFF position and turn off the water supply to the ice machine at the water service valve.
2. Disconnect water supply line at float valve quick disconnect by depressing stainless steel lever.
3. Place the toggle switch in the ICE position. The dump valve will open and the float reservoir will empty.
4. After the reservoir is empty, place the toggle switch in the OFF position and disconnect power to the ice machine at the service disconnect.
5. Remove water float valve coil.
  - A. Depress coil and rotate 1/4 turn counterclockwise.
  - B. With coil wires attached, lift coil off enclosure tube.
6. Remove top cover from float reservoir.
7. Lift float valve out of float reservoir.
8. Disconnect the drain lines from reservoir.
9. Lift reservoir off of evaporator assembly.

## Ice Diverter Removal

1. Place the toggle switch in the OFF position, turn off the water supply and disconnect electrical power to the ice machine.
2. Remove thumbscrews and lift panel forward.
3. Remove bin level sensor from white plastic panel.
4. Remove ice diverter from bin.

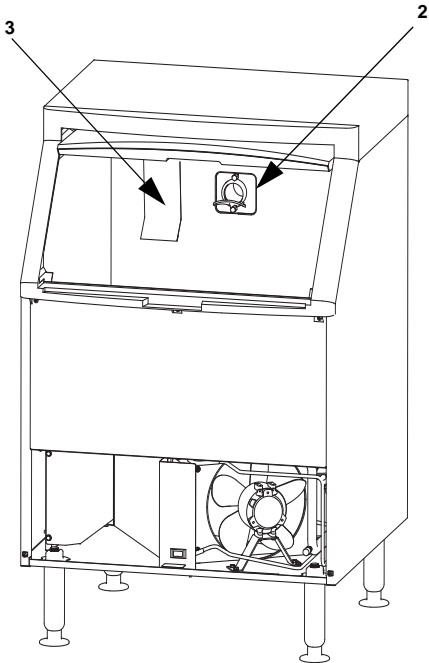

## Bin Door Removal

Door removal allows easier access for cleaning and sanitizing.

1. Disconnect the electrical power to the ice machine and remove ice from bin.
2. Grasp the rear of the bin door and pull bin door forward approximately 5".
3. Slide bin door to the rear while applying upward pressure (the rear door pins will ride up into the track slot).
4. Slide the rear door pins off the end and then below the door track. Slide bin door forward allowing the back of the door to lower into the bin. Continue forward with the bin door until the front pins bottom out in the track.
5. Lift the right side of the bin door until the front pin clears the track.
6. Remove door from bin.

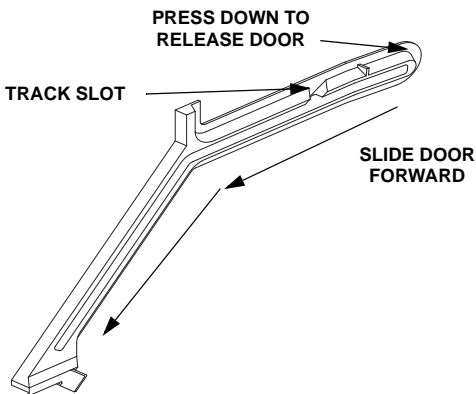

## Cabinet Removal

1. Remove all ice from bin and disconnect power.
2. Remove thumbscrews and evaporator panel.
3. Remove three screws from the bottom of the left and right side of cabinet.
4. Remove nine screws from back panel.
5. Disconnect drain line clamp.
6. Slide cabinet forward and remove from base.

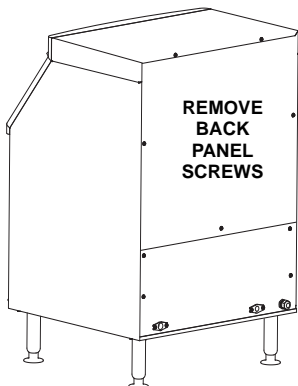
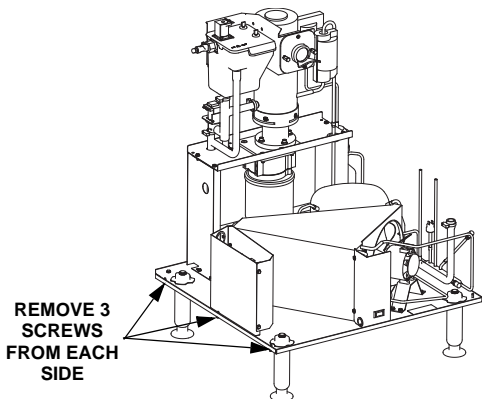

## QC0700/QF0800/QF2200/QF2300

### Removal of Parts for Cleaning or Sanitizing

#### Water Level Probe Removal

1. Place the toggle switch in the OFF position, turn off the water supply and disconnect electrical power to the ice machine.
2. Disconnect water supply line at float valve quick disconnect by depressing stainless steel lever.
3. Pull up on water level probes to remove.
4. Disconnect wires from water level probes or control board.

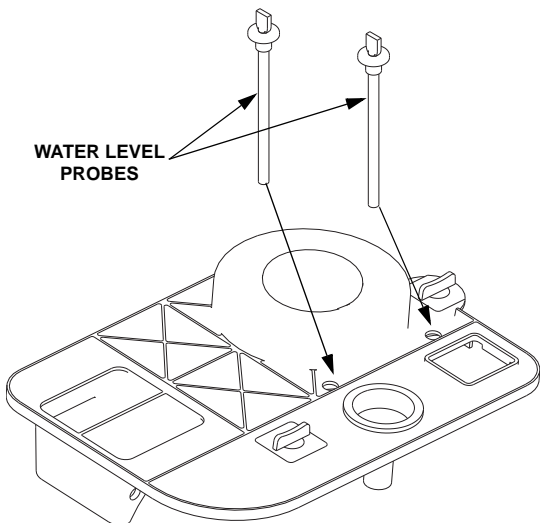

**QF0800/QC0700 SHOWN**

## Water Reservoir Cover Removal

1. Place the toggle switch in the OFF position, turn off the water supply and disconnect electrical power to the ice machine.
2. Remove water level probes.
3. Remove water float valve coil.
  - A. Depress coil and rotate 1/4 turn counterclockwise.
  - B. With coil wires attached, lift coil off enclosure tube.
4. QF0800/QC0700 ONLY Rotate quarter turn fasteners counterclockwise.
5. QF0800/QC0700 ONLY Remove cotter key and pin from ice chute.
6. Remove top cover from float reservoir.

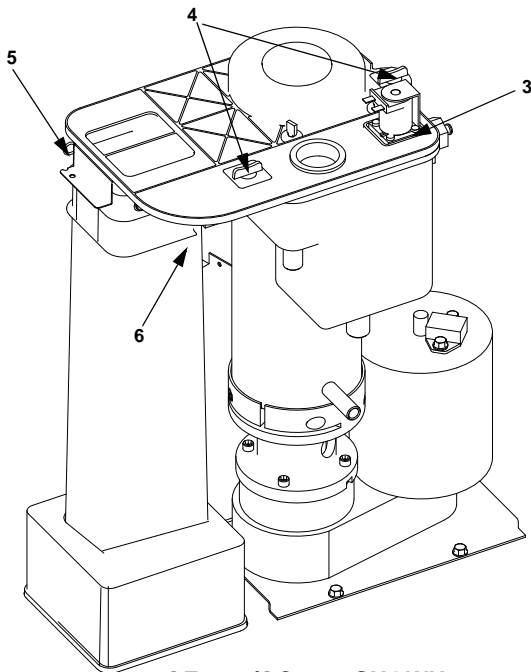

**QF0800/QC0700 SHOWN**



## Water Reservoir Cover Removal QF2200/QF2300

1. Place the toggle switch in the OFF position, turn off the water supply and disconnect electrical power to the ice machine.
2. Remove water level probes.
3. Remove water float valve coil.
4. Depress coil and rotate 1/4 turn counterclockwise.
5. With coil wires attached, lift coil off enclosure tube.
6. Remove top cover from float reservoir.

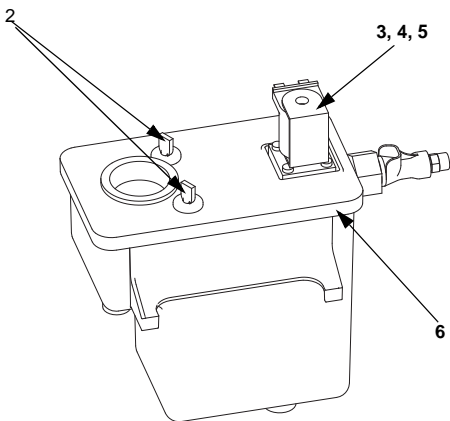

**QF2200/QF2300 Shown**

## Float Valve Removal

1. Place the toggle switch in the OFF position, turn off the water supply and disconnect electrical power to the ice machine.
2. Disconnect water supply line at float valve quick disconnect by depressing stainless steel lever.
3. Remove water float valve coil.
  - A. Depress coil and rotate 1/4 turn counterclockwise.
  - B. With coil wires attached, lift coil off enclosure tube.
4. QF0800/QC0700 ONLY Rotate quarter turn fasteners counterclockwise.
5. QF0800/QC0700 ONLY Remove cotter key and pin from ice chute.
6. Remove top cover from float reservoir.
7. Lift float valve out of float reservoir.



**QC0700/QF0800 Shown**

## Water Reservoir Removal

1. Place the toggle switch in the OFF position and turn off the water supply to the ice machine at the water service valve.
2. Disconnect water supply line at float valve quick disconnect by depressing stainless steel lever.
3. Place the toggle switch in the ICE position. The dump valve will open and the float reservoir will empty.
4. After the reservoir is empty, place the toggle switch in the OFF position and disconnect power to the ice machine at the service disconnect.
5. Remove water float valve coil.
6. Depress coil and rotate 1/4 turn counterclockwise.
7. With coil wires attached, lift coil off enclosure tube.
8. QF0800/QC0700 ONLY Rotate quarter turn fasteners counterclockwise.
9. QF0800/QC0700 ONLY Remove cotter key and pin from ice chute.  
QF2200/QF2300 ONLY Remove cotter key and retaining pin from water reservoir.
10. Remove top cover from float reservoir.
11. Lift float valve out of float reservoir.
12. Disconnect the drain lines from reservoir.
13. Lift reservoir off of evaporator assembly.

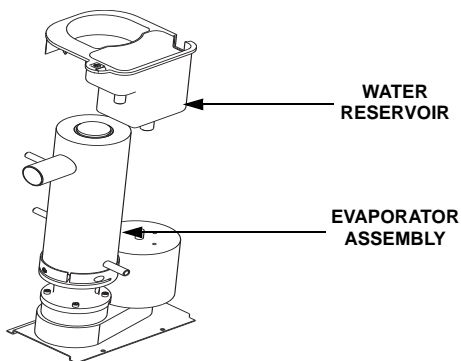

## Ice Chute Removal (QF0800/QC0700)

1. Follow steps to remove float reservoir.
2. The ice chute and ice chute grommet will be removed as a unit. Pull forward on the top of the ice chute, and slide the ice chute and grommet off the end of the evaporator spout.
3. Remove evaporator spout insulation.
4. Lift ice chute out of the base.
5. Remove insulation from the bottom of the ice chute.
6. Remove bin level sensor (stainless steel plate) from ice chute.

**NOTE:** Clean and sanitize the base and all ice chute components before reinstalling.

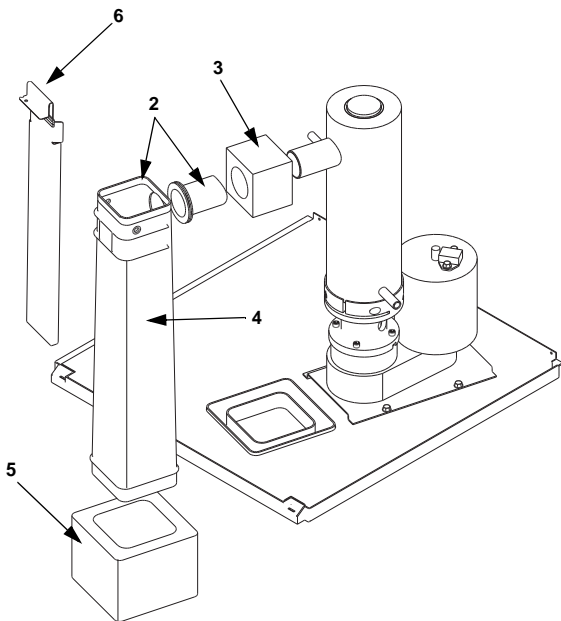

## QF2200/QF2300

1. Place the toggle switch in the OFF position, turn off the water supply and disconnect electrical power to the ice machine.
2. Remove ice chute retaining clamp from top of evaporator.
3. Remove vinyl hose from ice chute spout.
4. Follow steps to remove water reservoir.
5. The ice chute elbow and the ice chute will be removed separately. Support the ice chute and pull forward on the elbow to remove.
6. Lift ice chute out of the base, tip bottom forward and remove bin level sensor (stainless steel plate) from the top of the ice chute.
7. Remove insulation from ice chute elbow and ice chute base.
8. Remove evaporator spout o-ring.

NOTE: Clean and sanitize the base, spout and all ice chute components before reinstalling.

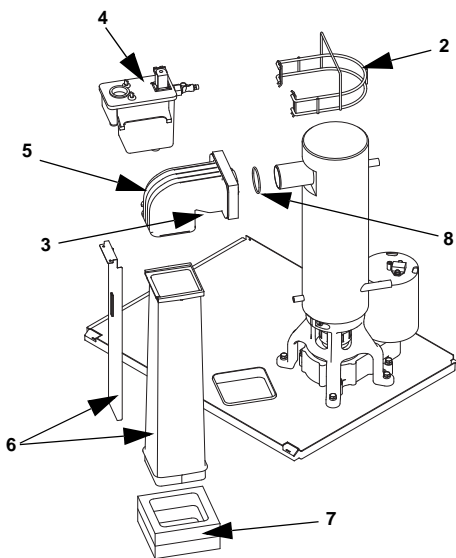

## SF400/SN450/SF600/SN650/SF900/SN950/SF1200/ SN1250

### Removal of Parts for Cleaning or Sanitizing

1. Remove front, side and top panels.
2. Perform the cleaning and sanitizing procedures.
3. Run the ice machine in the freeze cycle for 5 minutes, then place the toggle switch in the OFF position.
4. Disconnect the main power supply to the ice machine.
5. Remove the ice chute cover.
  - A. Turn the two thumbscrews 1/4 turn
  - B. Lift to remove cover.

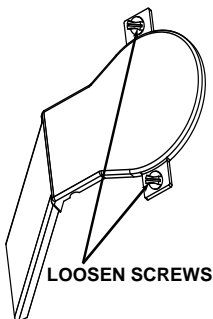

6. Turn ice wiper counterclockwise to remove.

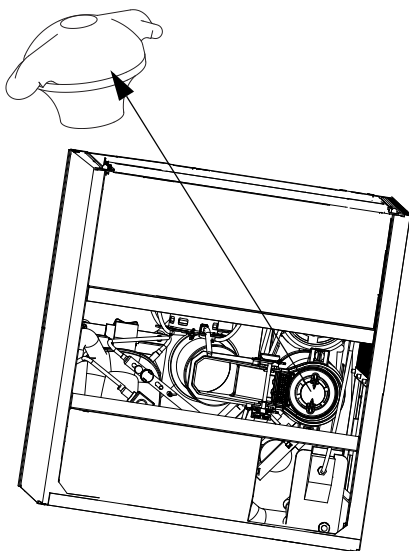

7. Disconnect the water supply.
8. Reconnect the main power supply to the ice machine.
9. Place toggle switch in the clean position for 30 seconds to drain water from reservoir, then move the toggle switch to the Off position.
10. Disconnect the main power supply to the ice machine.



### **Warning**

Disconnect electric power to the ice machine at the electric switch box before proceeding.

11. Lift out ice damper.

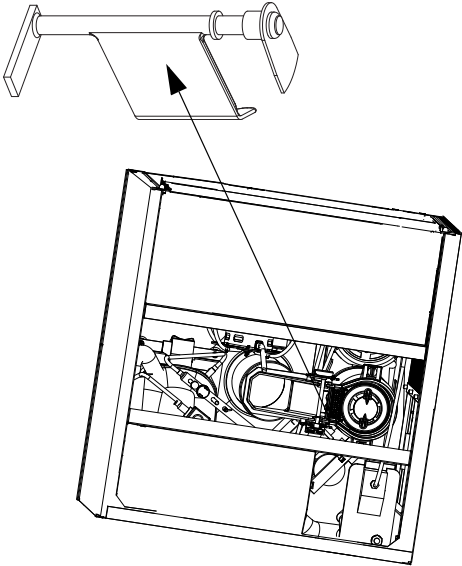

12. Lift out ice strainer ramp.

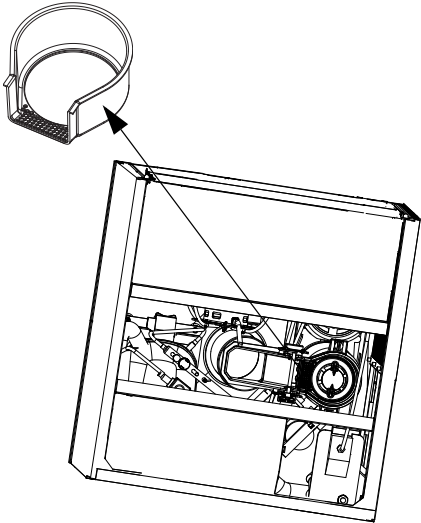



13. Loosen ice chute hose clamp.

14. Disconnect ice chute drain.

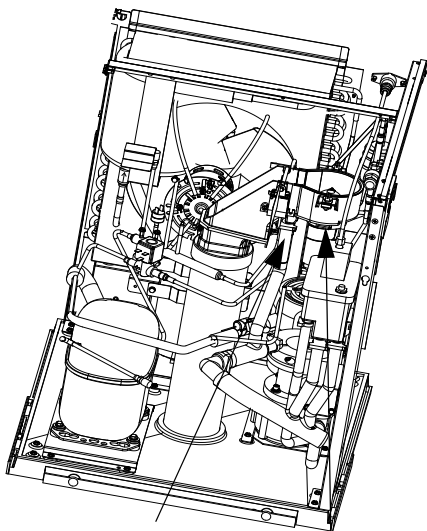

**ICE CHUTE DRAIN AND HOSE CLAMP**

15. Lift up on ice chute to remove.

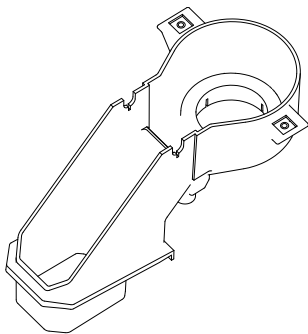

16. The ice chute can be cleaned in place. If complete removal is desired use a phillips screwdriver to remove the Hall Effect Switch assembly from the ice chute.

**REMOVE SCREW**

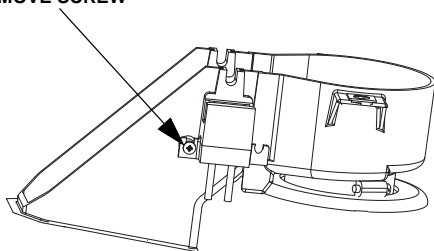

17. Remove ice chute collar and tube by lifting straight up.

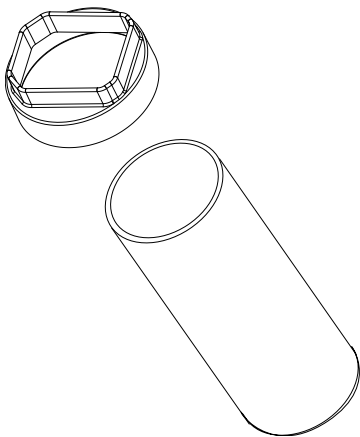

18. Remove water reservoir cover by pushing up on cover to snap off. The water reservoir can be cleaned in place.

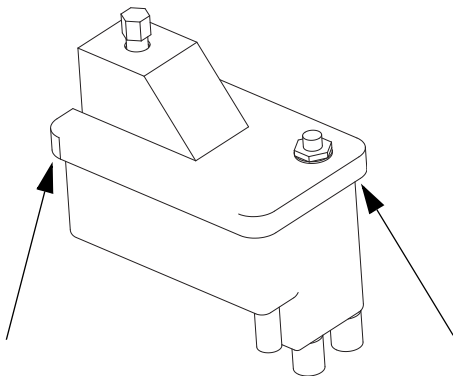

## SN012/SN020

### Removal of Parts for Cleaning or Sanitizing

1. Turn off water supply to ice machine.
2. Place toggle switch in the clean position for 30 seconds to drain water from reservoir, then move toggle switch to Off position.
3. Run dispenser to transfer all ice from the bin to a container.

#### **Warning**

Disconnect electric power to the ice machine at the electric switch box before proceeding.

4. Disconnect electrical power to the ice machine.
5. Remove top cover.
  - A. Remove two screws.
  - B. Lift up on top cover to remove.

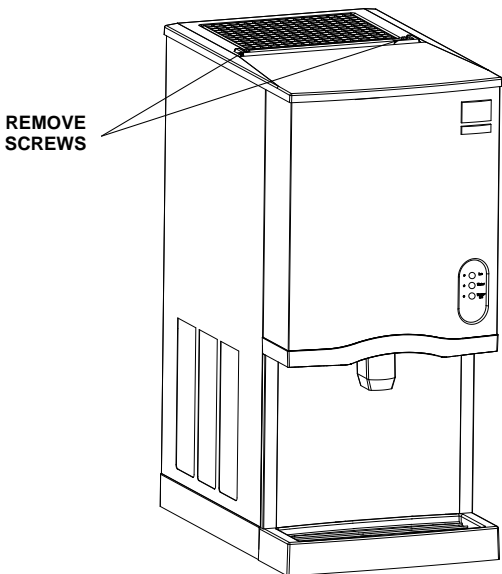

6. Remove front cover.
  - A. Lift up on front cover.
  - B. Pull forward to disengage keyhole slots.

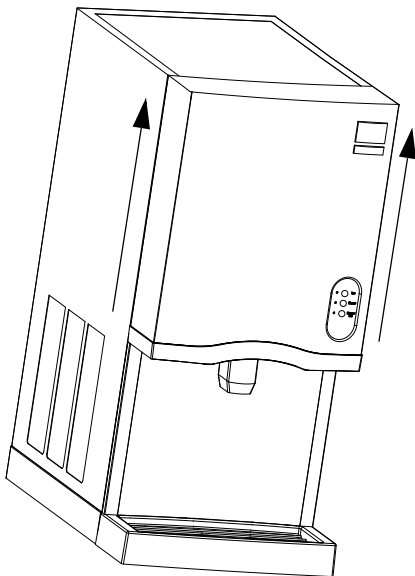

7. Remove side panels.

8. Remove ice chute cover
  - A. Turn the two thumbscrews 1/4 turn.
  - B. Lift to remove cover.

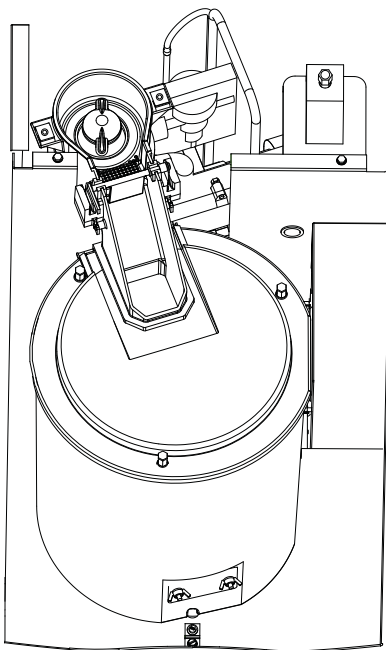
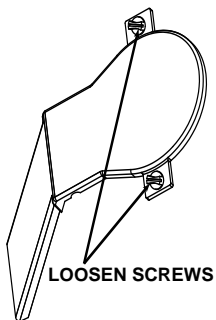

9. Lift out ice damper.

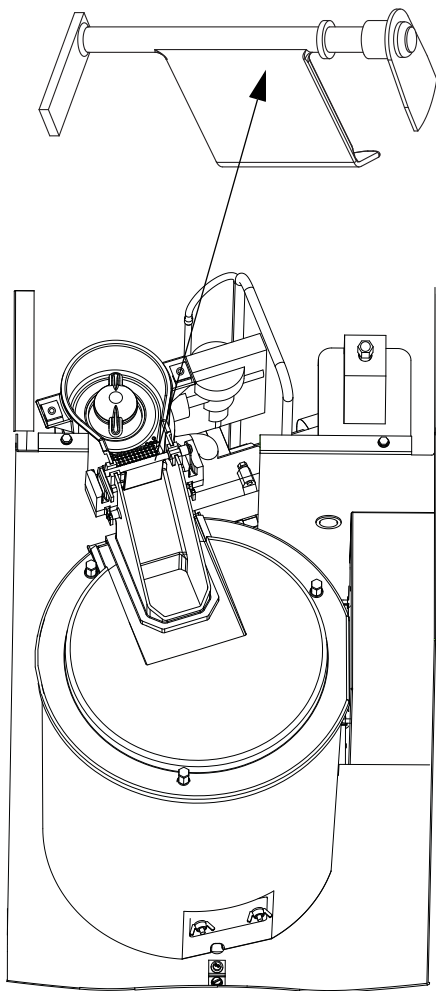

10. Lift out ice strainer ramp.

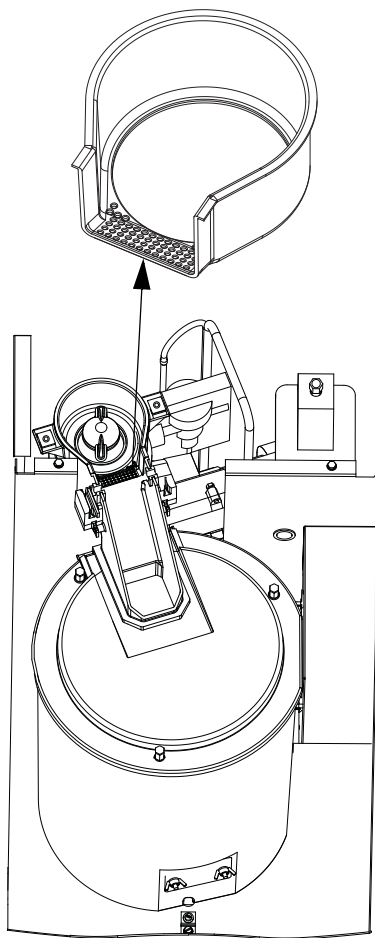



11. Turn ice wiper counterclockwise to remove.

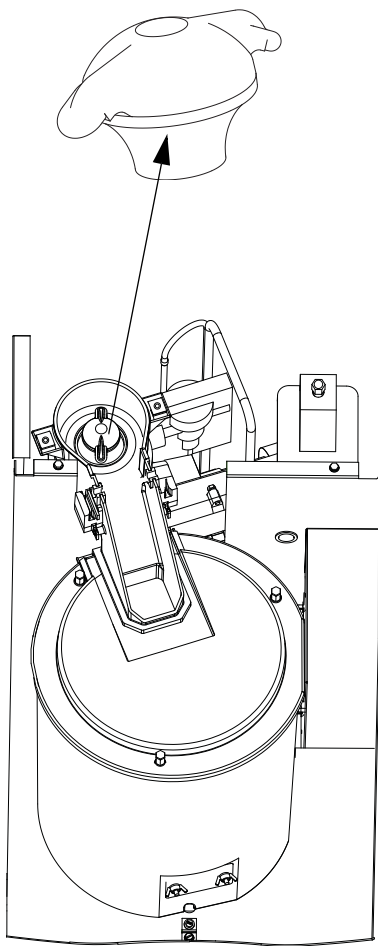

12. Loosen ice chute hose clamp.

13. Disconnect ice chute drain.

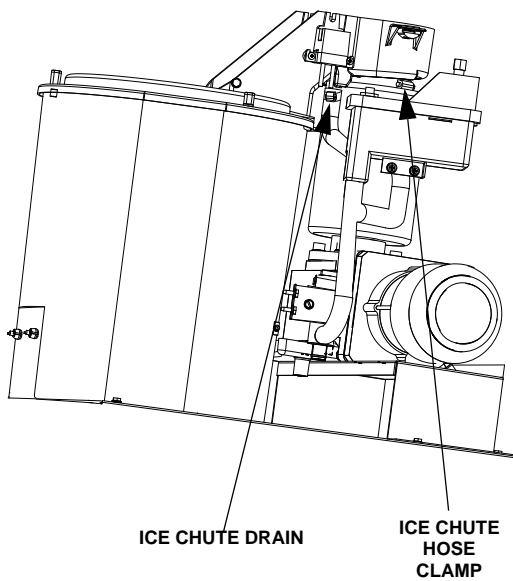

14. Lift up on ice chute to remove. The ice chute must be removed before the bin cover can be removed.

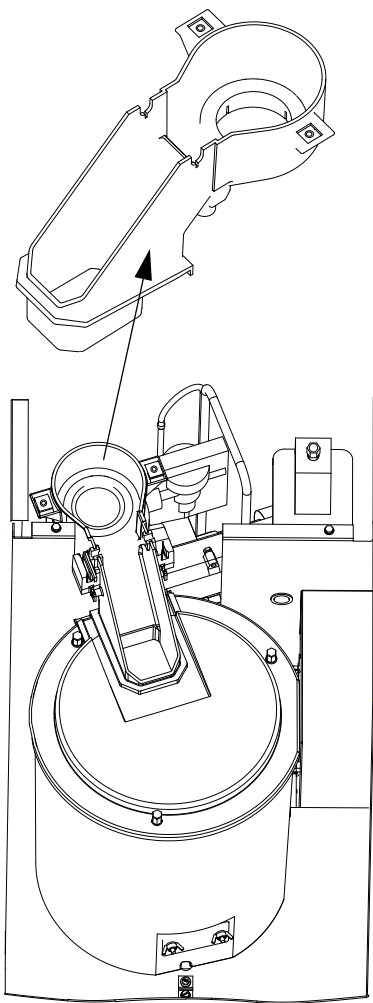

15. The ice chute can be cleaned in place. If complete removal is desired use a phillips screwdriver to remove the Hall Effect Switch assembly from the ice chute.

**REMOVE SCREW**

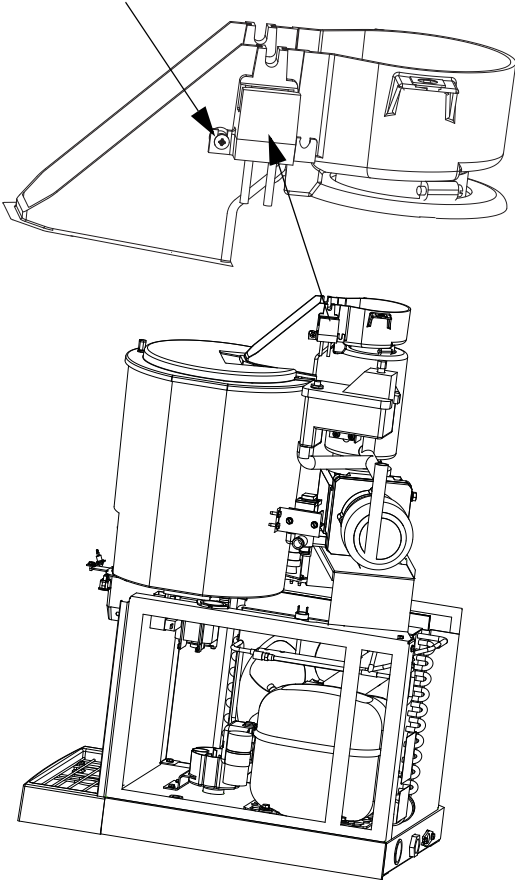

16. Remove three thumbscrews, then remove bin cover.

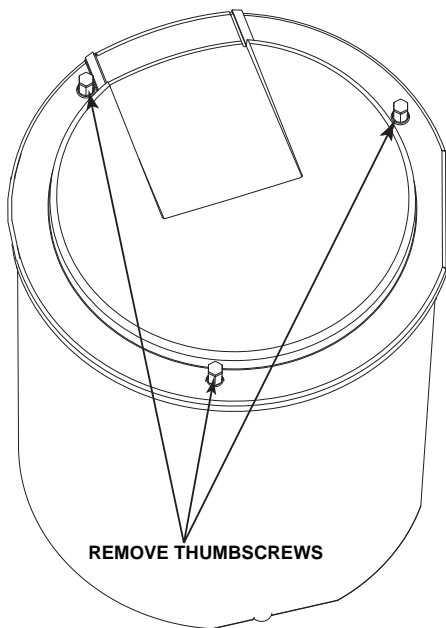

17. Remove agitator bar.

- SN012 - Remove the thumbscrew and lift off.
- SN020 - Unscrew the upright agitator bar.

NOTE: Bar must be reassembled by inserting front edge into the paddle wheel, then lowering the back edge (rounded 90 angle) to prevent water leakage into the compressor compartment.

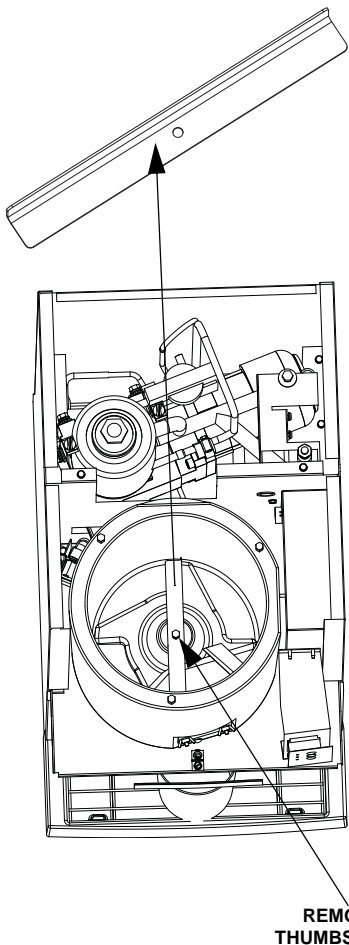

18. Remove ice deflector.

A. Remove the two thumbscrews.

B. Lift the ice deflector out.

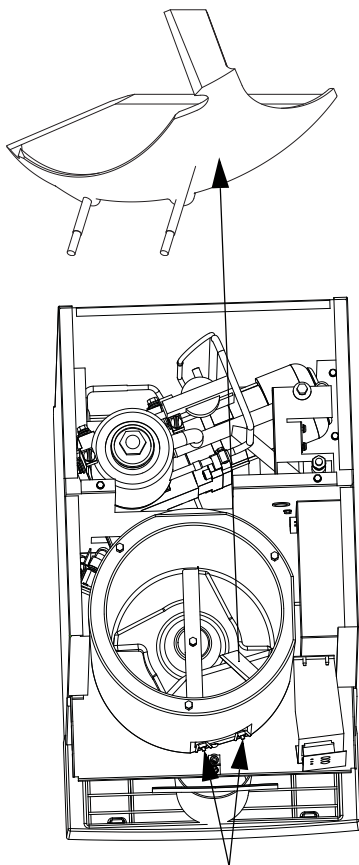

**REMOVE  
THUMBSCREW**

19. Remove ice dispensing wheel by lifting straight out.

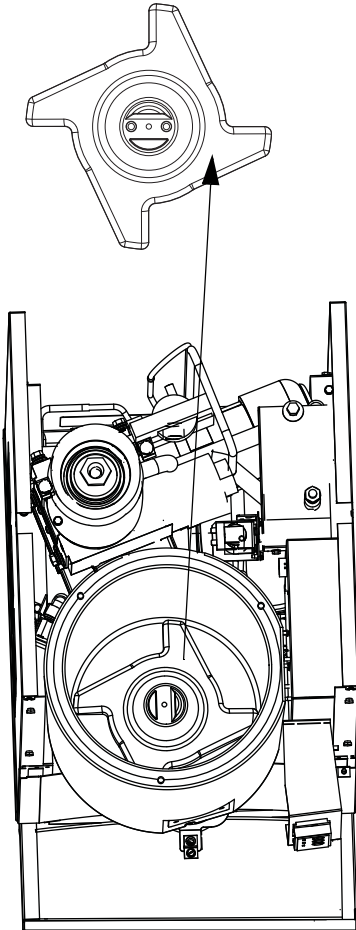



## 20. Water Reservoir Cover Removal

- A. Push up on cover to snap off.

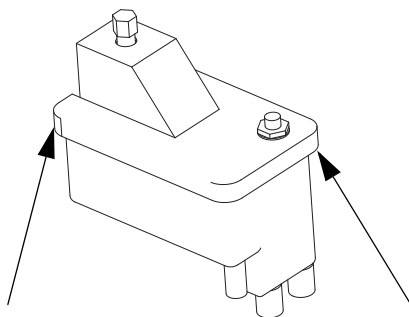

## WATER DUMP VALVE - ALL MODELS

The water dump valve normally does not require removal for cleaning. To determine if removal is necessary:

1. Set the toggle switch to OFF.
  2. Watch the water float valve. If the dump valve is leaking the float will continue to add water in the Off cycle.
- If the dump valve is leaking, remove, disassemble and clean it.
  - If the dump valve is not leaking, do not remove it. Instead, follow the "Cleaning Procedure".

Follow the procedure below to remove the dump valve.



### **Warning**

Disconnect the electric power to the ice machine at the electric service switch box and turn off the water supply before proceeding.

1. Depress and twist the coil 1/8 turn counterclockwise.
2. Leaving the wires attached, lift the coil assembly off the valve body.
3. Remove the plunger, nylon gasket and diaphragm from the valve body.

NOTE: At this point, the water dump valve can easily be cleaned. If complete removal is desired, continue with step 4.

4. Remove the tubing from the dump valve by twisting the clamps off.
5. Remove the valve body from mounting bracket by twisting counterclockwise.

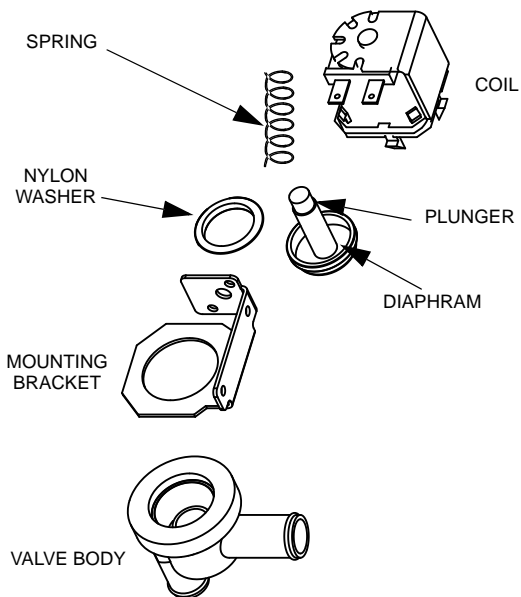

### Dump Valve Disassembly

## CLEANING THE CONDENSER



### Warning

Disconnect electric power to the ice machine at the electric service switch before cleaning the condenser. The condenser fins are sharp. Use care when cleaning them.

### Air-Cooled Condenser

A dirty condenser restricts airflow, resulting in excessively high operating temperatures. This reduces ice production and shortens component life. Clean the condenser at least every six months. Follow the steps below.

1. The washable aluminum filter on self-contained ice machines is designed to catch dust, dirt, lint and grease. This helps keep the condenser clean. Clean the filter with a mild soap and water solution.
2. Clean the outside of the condenser with a soft brush or a vacuum with a brush attachment. Clean from top to bottom, not side to side. Be careful not to bend the condenser fins.
3. Shine a flashlight through the condenser to check for dirt between the fins. If dirt remains:
  - A. Blow compressed air through the condenser fins from the inside. Be careful not to bend the fan blades.
  - B. Use a commercial condenser coil cleaner. Follow the directions and cautions supplied with the cleaner.
4. Straighten any bent condenser fins with a fin comb.
5. Carefully wipe off the fan blades and motor with a soft cloth. Do not bend the fan blades. If the fan blades are excessively dirty, wash with warm, soapy water and rinse thoroughly.



### Warning

If you are cleaning the condenser fan blades with water, cover the fan motor to prevent water damage.

## **Water-Cooled Condenser and Water Regulating Valve**

Symptoms of restrictions in the condenser water circuit include:

- Low ice production
- High water consumption
- High operating temperatures
- High operating pressures

If the ice machine is experiencing any of these symptoms, the water-cooled condenser and water regulating valve may require cleaning due to scale build-up.

The cleaning procedures require special pumps and cleaning solutions. Follow the manufacturer's instructions for the specific cleaner being used.

## Removal from Service/Winterization

### GENERAL

Special precautions must be taken if the ice machine is to be removed from service for an extended period of time or exposed to ambient temperatures of 32°F (0°C) or below.

#### **Caution**

If water is allowed to remain in the ice machine in freezing temperatures, severe damage to some components could result. Damage of this nature is not covered by the warranty.

Follow the applicable procedure below.

### **SELF-CONTAINED AIR-COOLED OR REMOTE AIR-COOLED ICE MACHINES**

1. Disconnect the electric power at the circuit breaker or the electric service switch.
2. Turn off the water supply.
3. Disconnect and drain the incoming ice-making water line at the rear of the ice machine.
4. Disconnect drain tubing (from the inlet to dump valve) and drain water into container and discard.
5. Make sure water is not trapped in any of the water or drain lines.

## WATER-COOLED ICE MACHINES

1. Perform steps 1-6 under "Self-Contained Air-Cooled Ice Machines."
2. Disconnect the incoming water and drain line from the water-cooled condenser.
3. Insert a large screwdriver between the bottom spring coils of the water regulating valve. Pry upward to open the valve.

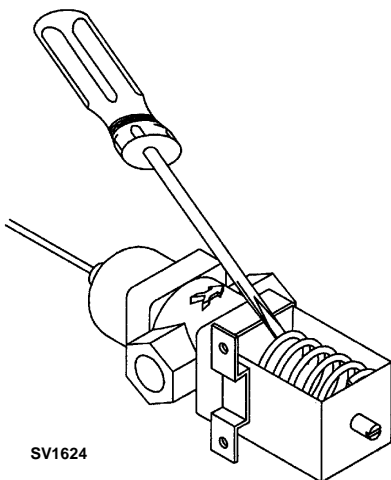

4. Hold the valve open and blow compressed air through the condenser until no water remains.

## REMOTE ICE MACHINES

1. Move the ICE/OFF/CLEAN switch to OFF.
2. "Frontseat" (shut off) the receiver service valve. Hang a tag on the switch as a reminder to open the valves before restarting.
3. Perform steps 1-6 under "Self-Contained Air-Cooled Ice Machines."

**This Page Intentionally Left Blank**



# Operation

---

## Ice Making Sequence of Operation

QF0400/QC0700/QF0800

### Ice Making Sequence of Operation

#### PRIOR TO START-UP

When the toggle switch is placed in the “ice” position the following must occur prior to starting an ice making cycle.

- The **bin level probe** must be **open** (bin level light off). If the probe is closed, (bin level light on) when the toggle switch is moved to ICE, the control system waits until the bin level probe opens, (bin level light off) before starting an ice making sequence. If the bin level probe is removed/disconnected the ice machine will not start.
- The **water level probe** must be **closed** (water level light on) to start the compressor. If the water level probe is open, (water level light off) the control system waits until the water level probe closes before starting the compressor.

#### INITIAL START-UP

##### 1A. FLUSH

Immediately after placing the toggle switch into ICE, the dump valve solenoid, and gearbox are energized. After 45 seconds the dump valve de-energizes.

##### 1B. WATER FILL

After 45 seconds the water float valve solenoid is energized.

#### 2. FREEZE CYCLE

When water contacts the water level probe, the compressor and condenser fan motor energize (condenser fan motor is wired through a fan cycling control). The gear motor, compressor, condenser fan motor and water float valve solenoid remain energized as the ice machine makes ice. The water float valve will open and close automatically to maintain the proper water level.

## AUTOMATIC SHUT-OFF

### 3A. Ice Run Out

Ice will build up in the bin until it contacts the bin level probe. After ice contacts the bin level probe for 30 continuous seconds the compressor de-energizes. To allow excess ice to run out, the gear motor and the water float valve solenoid remain energized for an additional 4 minutes, then de-energize.

### 3B. Water Drain

To allow water to drain from the evaporator, the dump valve energizes for 45 seconds, then de-energizes.

An 8-minute lockout starts when the compressor de-energizes. When the ice drops away from the bin level probe the ice machine will begin an initial start-up cycle, provided the "8-minute lockout" has expired.

#### **8 Minute Lockout**

The bin level light will flash until the 8-minute lockout expires.

After the 8 minute lockout expires the bin level light will de-energize.

The 8 minute lockout time can be overridden by moving the ON/OFF/CLEAN toggle switch from ICE to OFF then back to ICE.

#### **Flush Sequence in the "ICE" Position**

After the ice machine has run for 100 hours the ice machine will stop making ice and perform a flush sequence. The flush sequence will remove minerals that have settled in the bottom of the evaporator. The entire flush sequence lasts approximately 11 minutes, after which the ice machine automatically resumes ice making and the 100 hour counter in the control board resets to zero.

Flake ice machines use an auger to remove ice from the evaporator. Occasional noises (creaks, groans, or pops) are normal.

## QF2200

### Ice Making Sequence of Operation

#### PRIOR TO START-UP

When the toggle switch is placed in the “ice” position the following must occur prior to starting an ice making cycle.

- A. The **bin level probe** must be **open** (bin level light off). If the probe is closed, (bin level light on) when the toggle switch is moved to ICE, the control system waits until the bin level probe opens, (bin level light off) before starting an ice making sequence. If the bin level probe is removed/disconnected the ice machine will not start.
- B. The **water level probe** must be **closed** (water level light on) to start the compressor. If the water level probe is open, (water level light off) the control system waits until the water level probe closes before starting the compressor.

#### INITIAL START-UP

##### **1A. Flush**

Immediately after placing the toggle switch into ICE, the dump valve solenoid, and gearbox are energized. After 45 seconds the dump valve de-energizes.

##### **1B. Water Fill**

After 45 seconds the water float valve solenoid is energized.

##### **2. Freeze Cycle**

When water contacts the water level probe the compressor and condenser fan motor energize (condenser fan motor is wired through a fan cycling control).

The gear motor, compressor, condenser fan motor and water float valve solenoid remain energized as the ice machine makes ice. The water float valve will open and close automatically to maintain the proper water level.

## **Remote Condensing Unit**

### **3. Freeze**

When the refrigerant pressure is high enough, the low-pressure control closes. Closing the low pressure control energizes the contactor coil and the compressor starts.

The compressor increases the refrigerant pressure, the fan cycling control closes and the condenser fan motor starts. The compressor and condenser fan motor remain energized during the entire Freeze Cycle.

### **AUTOMATIC SHUT-OFF**

#### **4A. Ice Run Out**

Ice will build up in the bin until it contacts the bin level probe. After ice contacts the bin level probe for 30 continuous seconds the compressor de-energizes. To allow excess ice to run out, the gear motor and the water float valve solenoid remain energized for an additional 4 minutes, then de-energize.

#### **4B. Water Drain**

To allow water to drain from the evaporator, the dump valve energizes for 90 seconds, then de-energizes.

An 8-minute lockout starts when the compressor de-energizes. When the ice drops away from the bin level probe the ice machine will begin an initial start-up cycle, provided the "8-minute lockout" has expired.

#### **8 Minute Lockout**

An 8 minute lockout starts when the compressor de-energizes. The bin level light will flash until the 8-minute lockout expires.

After the 8 minute lockout expires the bin level light will de-energize.

The 8 minute lockout time can be overridden by moving the ON/OFF/CLEAN toggle switch from ICE to OFF then back to ICE.

## **Flush Sequence in the “ICE” Position**

After the ice machine has run for 100 hours the ice machine will stop making ice and perform a flush sequence. The flush sequence will remove minerals that have settled in the bottom of the evaporator. The entire flush sequence lasts approximately 11 minutes, after which the ice machine automatically resumes ice making and the 100 hour counter in the control board resets to zero.

NOTE: Flake ice machines use an auger to remove ice from the evaporator. Occasional noises (creaks, groans, or pops) are a normal part of the ice making process.

## **Remote Condensing Unit**

### **5. Automatic Shut-Off**

When the refrigerant pressure is low enough to open the low-pressure switch, the contactor coil is de-energized and the compressor and condenser fan motor stop.

## Energized Parts QF2200

Sequence	Control Relays				Sensors				Duration
	1	2	3	4	Water Level Probe	Bin Level Probe	Temperature Sensor	Gear Motor Speed	
	Liquid Line Solenoid Valve	Dump Valve	Gear Motor	Float Valve Coil					
Start-Up 1A. Water Flush	Off	On	On	Off	Not Sensing Water Level	Sensing No Ice Contact	Not Sensing for Temperature	Sensing for Gear Motor Speed	45 Seconds
1B. Water Fill	Off	Off	On	On	Sensing Water Level	Sensing No Ice Contact	Not Sensing for Temperature	Sensing for Gear Motor Speed	Until Water Contacts Water Level Probe
2. Freeze Cycle	On	Off	On	On	Sensing Water Level	Sensing No Ice Contact	Sensing for 123°F Immediately Sensing for 30°F After 30 Min. of Ice Making	Sensing for Gear Motor Speed	Until Ice Contacts Bin Level Probe for 30 Continuous Seconds
Automatic Shut-Off Sequence 3A. Ice Run Out	Off	Off	On	On	Sensing Water Level	Sensing Ice Contact	Not Sensing for Temperature	Sensing for Gear Motor Speed	4 Minutes

**Energized Parts (Continued)****QF2200**

Sequence	Control Relays				Sensors				Duration
	1	2	3	4	Water Level Probe	Bin Level Probe	Temperature Sensor	Gear Motor Speed	
	Liquid Line Solenoid Valve	Dump Valve	Gear Motor	Float Valve Coil					
3B. Drain Evaporator	Off	On	Off	Off	Not Sensing Water Level	Sensing Ice Contact	Not Sensing for Temperature	Not Sensing for Gear Motor Speed	90 Seconds
Automatic Shut-Off	Off	Off	Off	Off	Not Sensing Water Level	Sensing Ice Contact	Not Sensing for Temperature	Not Sensing for Gear Motor Speed	Until Ice No Longer Contacts Bin Level Probe

## QF2300

### Ice Making Sequence of Operation

#### PRIOR TO START-UP

When the toggle switch is placed in the “ice” position the following must occur prior to starting an ice making cycle.

- A. The **bin level probe** must be **open** (bin level light off). If the probe is closed, (bin level light on) when the toggle switch is moved to ICE, the control system waits until the bin level probe opens, (bin level light off) before starting an ice making sequence. If the bin level probe is removed/disconnected the ice machine will not start.
- B. The **water level probe** must be **closed** (water level light on) to start the compressor. If the water level probe is open, (water level light off) the control system waits until the water level probe closes before starting the compressor.

#### INITIAL START-UP

##### **1A. Flush**

Immediately after placing the toggle switch into ICE, the dump valve solenoid, and gearbox are energized. After 45 seconds the dump valve de-energizes.

##### **1B. Water Fill**

After 45 seconds the water float valve solenoid is energized.

##### **2. Freeze Cycle**

When water contacts the water level probe the liquid line solenoid valve, equalization valve, compressor and condenser fan motor energize (condenser fan motor is wired through a fan cycling control).

The gear motor, compressor, condenser fan motor and water float valve solenoid remain energized as the ice machine makes ice. The water float valve will open and close automatically to maintain the proper water level.



## AUTOMATIC SHUT-OFF

### **3A. Ice Run Out**

Ice will build up in the bin until it contacts the bin level probe. After ice contacts the bin level probe for 30 continuous seconds the liquid line solenoid valve, equalization valve, and compressor de-energize. To allow excess ice to run out, the gear motor and the water float valve solenoid remain energized for an additional 4 minutes, then de-energize.

### **3B. Water Drain**

To allow water to drain from the evaporator, the dump valve energizes for 90 seconds, then de-energizes.

An 8-minute lockout starts when the compressor de-energizes. When the ice drops away from the bin level probe the ice machine will begin an initial start-up cycle, provided the “8-minute lockout” has expired.

### **8 Minute Lockout**

The bin level light will flash until the 8-minute lockout expires.

After the 8 minute lockout expires the bin level light will de-energize.

The 8 minute lockout time can be overridden by moving the ON/OFF/CLEAN toggle switch from ICE to OFF then back to ICE.

### **Flush Sequence in the “ICE” Position**

After the ice machine has run for 100 hours the ice machine will stop making ice and perform a flush sequence. The flush sequence will remove minerals that have settled in the bottom of the evaporator. The entire flush sequence lasts approximately 11 minutes, after which the ice machine automatically resumes ice making and the 100 hour counter in the control board resets to zero.

Flake ice machines use an auger to remove ice from the evaporator. Occasional noises (creaks, groans, or pops) are a normal part of the ice making process.

## Energized Parts QF2300

Sequence	Control Relays				Sensors			Duration
	1	2	3	4	Water Level Probe	Bin Level Probe	Gear Motor Speed	
	Liquid Line Solenoid Valve/ Equalization Valve/ Compressor	Dump Valve	Gear Motor	Float Valve Coil				
Start-Up 1A. Water Flush	Off	On	On	Off	Not Sensing Water Level	Sensing No Ice Contact	Sensing for Gear Motor Speed	45 Seconds
1B. Water Fill	Off	Off	On	On	Sensing Water Level	Sensing No Ice Contact	Sensing for Gear Motor Speed	Until Water Contacts Water Level Probe
2. Freeze Cycle	On	Off	On	On	Sensing Water Level	Sensing No Ice Contact	Sensing for Gear Motor Speed	Until Ice Contacts Bin Level Probe for 3 Continuous Minutes
Automatic Shut-Off Sequence 3A. Ice Run Out	Off	Off	On	On	Not Sensing Water Level	Sensing Ice Contact	Sensing for Gear Motor Speed	4 Minutes

**Energized Parts (Continued)****QF2300**

Sequence	Control Relays				Sensors			Duration
	1	2	3	4	Water Level Probe	Bin Level Probe	Gear Motor Speed	
	Liquid Line Solenoid Valve/ Equalization Valve/ Compressor	Dump Valve	Gear Motor	Float Valve Coil				
3B. Drain Evaporator	Off	On (90 Sec.)	Off	Off	Not Sensing Water Level	Sensing Ice Contact	Not Sensing for Gear Motor Speed	90 Seconds
Automatic Shut-Off	Off	Off	Off	Off	Not Sensing Water Level	Sensing Ice Contact	Not Sensing for Gear Motor Speed	Until Ice No Longer Contacts Bin Level Probe

## **SN012/SN020/SF0400/SN0450/SF0600/SN0650/ SF0900/SN0950/SF1200/SN1250 NUGGET/FLAKE MACHINES**

### **Ice Making Sequence of Operation**

#### **PRIOR TO STARTUP**

When the toggle switch is placed in the ICE position the following must occur in the listed order before ice making will start.

- The 5 minute delay period must be expired. The delay period starts upon application of power or a change in toggle switch position.
- The ice chute damper must be in the closed or down position.
- The water sensing switch must be closed (water reservoir full of water and water sensing float in the up position).

#### **INITIAL STARTUP**

A 5 minute delay period must expire. The delay period starts to time out upon application of power and can not be overridden. When the five minute delay period expires, the gear motor energizes. The water in the reservoir closes the water sensing (float switch) and the compressor and condenser fan motor energize.

#### **FREEZE CYCLE**

The float valve automatically maintains the water level in the reservoir. The ice damper will open and close to verify ice production. The ice machine will continue to make ice until the ice damper is held open (up) as ice fills the bin.

## AUTOMATIC SHUTOFF

When the ice damper is held open by ice, the gearmotor, compressor and condenser fan de-energize. The five minute delay period starts to time out. The ice machine will remain off until the 5 minute delay period expires and the ice damper closes.

## RESTART AFTER AUTOMATIC SHUTOFF

The 5 minute delay period must be expired. The delay period starts when the ice machine enters Automatic Shutoff and can not be overridden.

1. The ice machine was off for less than 30 minutes.

When the 5 minute delay period expires, the gear motor, compressor and condenser fan motor energize.

2. The ice machine was off for more than 30 minutes.

The gear motor and dump valve energize to drain the water from the evaporator and reservoir. After 30 seconds the dump valve de-energizes. When the reservoir fills with water, the water sensing switch closes and the compressor and condenser fan motor energize.

## CHANGING TOGGLE SWITCH POSITION IN THE FREEZE CYCLE

Moving the toggle switch from ICE to OFF will start a 5 minute delay period.

- Moving the toggle switch immediately to the ICE position - The ice machine waits 5 minutes then starts.
- Moving the toggle switch to the ICE position after 5 minutes have elapsed - The ice machine immediately starts.

## **Control Board Features**

### **FLUSH CYCLE**

After the ice machine has completed 50 hours of run time a flush sequence will start. This cycle will drain and refill the evaporator to remove minerals that have settled to the bottom of the evaporator. The flush sequence lasts approximately 21 minutes, after which the ice machine will reset the 50 hour counter and automatically start ice making again.

### **POWER INTERRUPTION DELAY**

If power is disconnected the ice machine stops. When power is reapplied a 5 minute delay is initiated.

### **MAINTENANCE REQUIRED INDICATOR**

The maintenance required light on Nugget Ice Machines will energize and flash after 10,000 hours of run time. The ice machine will need to be serviced to ensure future reliability.

### **SAFEGUARDS**

The ice machine control board has safety features to protect the ice machine from severe failures. The ice machine will stop when conditions arise that would cause major component failure. Refer to Safeguards for details.

### **Water Level Check**

The float valve maintains the correct water level. The water level is factory set and normally will not require adjustment. The water level is correct if the Water Level indicator light is energized and no water is entering the overflow tube.

The float valve is secured with 2 stop nuts. If an adjustment is required raise or lower the stop nuts as needed.

**ENERGIZED PARTS**  
**S Model Nugget/Flake Machines**

<b>Sequence</b>	<b>Contactor Coil</b>	<b>Dump Valve</b>	<b>Gear Motor</b>	<b>Ice Damper</b>	<b>Duration</b>
<b>Initial Start-Up</b> The 5 minute delay must expire first	Off	Off	On	Closed	Immediate
<b>Freeze Cycle</b>	On	Off	On	Moves to Verify Ice Production	Until Ice Holds Damper Open
<b>Automatic Shut-Off</b>	Off	Off	Off	Open	Until Damper Closes
<b>Restart</b> More than 30 minutes have passed since automatic shutoff cycle initiated	Off	On	On	Closed	30 Seconds
<b>Restart</b> Less than 30 minutes have passed since automatic shutoff cycle initiated	Off	Off	On	Closed	Immediate

**This Page Intentionally Left Blank**



# Troubleshooting

## SafeGuard Feature

The ice machine will stop when conditions arise that would cause major component failure.

### Standby Mode

The first time a failure occurs, the ice machine de-energizes and initiates a Standby Mode. The ice machine will remain off for 60 minutes, then automatically restart to see if the problem reoccurs. During the Standby Mode the corresponding light flashes continuously (disch temp, water level or speed). If the same failure keeps occurring, the ice machine will initiate a SafeGuard Mode and remain off until manually restarted.

### SafeGuard Indicator Lights

During a SafeGuard Mode the corresponding light (disch temp, water level or speed) will flash continuously.

The SafeGuard will remain in memory for 48 hours of ice making time. After 48 hours of ice making time the SafeGuard will automatically be erased. If power is interrupted during the 48 hours, the timing will resume when power is applied to the ice machine.

### Placing the toggle switch in the OFF position:

The corresponding light will flash continuously.

### Placing the toggle switch in the ICE position:

The light will de-energize and a start-up sequence will initiate. The corresponding light will flash anytime the toggle switch is placed in the OFF position provided 48 hours of ice making time has not been exceeded.

## Reset Procedure

1. Move the ICE/OFF/CLEAN toggle switch to OFF.
  - A. If a safeguard feature has stopped the ice machine, it will restart after a short delay. Proceed to Step 2.
  - B. If the ice machine does not restart, see “Ice Machine Does Not Operate.”
2. Allow the ice machine to run to determine if the condition is reoccurring.
  - A. If the ice machine continues to run, the condition has corrected itself. Allow the ice machine to continue running.
  - B. If the ice machine stops determine the safeguard mode, then refer to the specific safeguard for troubleshooting procedures.

## QF0400/QC0700/QF0800/QF2200/QF2300

### SafeGuards

- No Water
- Gear Motor Speed is Incorrect
- Discharge line temp. is too high or low during the freeze cycle.

### NO WATER SAFEGUARD

During the Freeze cycle if the water level probe opens or remains open for more than 90 continuous seconds\*, the ice machine:

1. De-energizes the compressor and/or gear motor.
2. Continuously flashes the Water Level Probe light.
3. Initiates a 60 minute Standby Mode.

During the Standby Mode the Water Level Probe light will continually flash to indicate a Standby Mode.

After the 60-minute Standby Mode, the ice machine will de-energize the Water Level Probe light and initiate a start-up sequence.

#### Water contacts the water level probe:

The ice machine will continue to make ice.

#### Water level probe opens or remains open for more than 90 continuous seconds\*:

The ice machine will start another 60-minute Standby Mode.

The ice machine repeats the above sequence until:

- Water contacts the water level probe.

**or**

- The toggle switch is moved to the OFF position.

NOTE: There are 2 control boards one remains open for 90 seconds and the other for 30 seconds.

Replacement boards will have the 30 second time.

### Indicator Light

#### Before 48 hours have elapsed:

After a Standby Mode has been initiated the Water Level Probe light will flash anytime the toggle switch is placed in the OFF position.

#### After 48 hours have elapsed:

The SafeGuard will be automatically erased from memory and the Water Level Probe light will not flash.

### **No Water Checklist**

<b>Possible Problem List</b>	<b>Corrective Action List</b>
No water	Restore water supply.
Quick disconnect removed from water float valve	Restore water supply.
Water float valve screen blocked	Clean screen.
Water float valve solenoid coil defective	Replace coil (see Water float valve diagnostics).
Water float valve improperly adjusted	Adjust valve (see Water level check).
Dump valve leaking	Repair or replace dump valve.
Water level probes disconnected or removed	Connect and correctly position probes.

## **GEAR MOTOR SPEED**

### **QF0400/QC0700/QF0800/QF2200/QF2300**

Anytime the motor speed sensor detects the motor speed (RPM) is below the minimum range for 3 continuous seconds, the ice machine will:

1. De-energize the compressor and/or gear motor.
2. Continuously flash the Gear Motor Speed light.
3. Initiate a 60-minute Standby Mode.

During the Standby Mode the Motor Speed Sensor light will flash to indicate a Standby Mode.

After the 60-minute Standby Mode, the ice machine will de-energize the Motor Speed light and initiate a start-up sequence.

#### Gear motor speed normal:

The ice machine continues to make ice.

#### Gear motor speed below minimum range for 3 continuous seconds:

The ice machine will start another 60-minute Standby Mode.

If the gear motor speed drops below the minimum range for 3 continuous seconds during 7 consecutive cycles, the ice machine will initiate a SafeGuard Mode.

During the SafeGuard Mode the Motor Speed Sensor light will continually flash to indicate a SafeGuard Mode.

The ice machine remains off until:

- The toggle switch is moved from ICE to OFF, then back to ICE.
- Line voltage is interrupted and restored.

#### **Indicator Light**

##### Before 48 hours have elapsed:

After a Standby Mode has been initiated the Gear Motor Speed light will flash anytime the toggle switch is placed in the OFF position.

##### After 48 hours have elapsed:

The SafeGuard will be automatically erased from memory and the Gear Motor Speed light will not flash.

## Gear Motor Speed Checklist

QF0400/QC0700/QF0800/QF2200/QF2300

Possible Problem List	Corrective Action List
Low water pressure	Verify water pressure is between 20 and 80 psig.
Defective motor speed sensor	Replace motor speed sensor.
Defective motor	Replace motor.
Defective coupler	Replace coupler.
Defective evaporator/auger assembly	Replace evaporator assembly.
Low voltage	Verify voltage is within $\pm 10\%$ of nameplate voltage.
Ice frozen to auger/evaporator	Allow evaporator to thaw.

## **TEMPERATURE IS TOO HIGH OR TOO LOW QF0400/QC0700/QF0800**

The temperature sensor (thermistor) is mounted on the compressor discharge line. The temperature sensor provides input to the control board. The control board monitors the temperature anytime the compressor is energized.

### **If the thermistor detects 245°F or higher for 15 continuous seconds:**

1. The ice machine will de-energize the compressor and gear motor and initiate a SafeGuard Mode.
2. The control board "Disch Temp" light will continue to flash twice then pause, to indicate the ice machine has shut off on high temperature.
3. The ice machine will remain off until the toggle switch is moved from ICE to OFF, and back to ICE.

**or**

Line voltage is interrupted and restored.

### **If the thermistor detects 155°F or less for 3 continuous minutes:**

1. The control board ignores the low temperature limit for the first 30 minutes of compressor run time.
2. The ice machine will de-energize the compressor and gear motor, continuously flash the control board "Disch Temp" light and initiate a 60-minute Standby Mode.
3. After the 60-minute Standby Mode, the ice machine will de-energize the "Disch Temp" light and initiate a start-up sequence.
4. After 30 minutes of compressor run time, the ice machine will check the discharge line temperature.

### Discharge line temperature normal:

The ice machine continues to make ice.

### Discharge line temperature below 155°F after 30 minutes of run time:

The ice machine will start another 60-minute Standby Mode.

If the discharge line temperature drops below 155°F for 3 continuous minutes during 7 consecutive cycles the ice machine will start a SafeGuard Mode.

During the SafeGuard Mode the "Disch Temp" light will continually flash to indicate a Safeguard Mode. The ice machine remains off until:

- The toggle switch is moved from ICE to OFF, then back to ICE.
- Line voltage is interrupted and restored.

### **Indicator Light**

#### Before 48 hours have elapsed:

After a Standby Mode has been initiated the Control Board "Disch Temp" light will flash anytime the toggle switch is placed in the OFF position.

#### After 48 hours have elapsed:

The SafeGuard will be automatically erased from memory and the "Disch Temp" light will not flash.



## Temperature Sensor Checklist

### QF0400/QC0700/QF0800

Possible Problem List	Corrective Action List
Thermistor is not properly insulated	Insulate thermistor.
Thermistor loose	Secure thermistor to discharge line.
Thermistor mounted in the wrong location	Position thermistor on discharge line 6 in. from compressor discharge port.
Thermistor defective	Refer to CHECK PROCEDURE under "Thermistor."
Flooding expansion valve	Replace expansion valve.
Refrigerant overcharge or undercharge	Recover and weigh in nameplate charge.
Low ambient temperature	Verify ambient temperature remains above 45°F (7.2°C).
Defective compressor	Replace compressor.
Insufficient or low water pressure	Verify water pressure is between 20 and 80 psig.

## **QF2200 ONLY - TEMPERATURE IS TOO HIGH OR LOW**

The temperature sensor (thermistor) is mounted on the liquid line. The temperature sensor provides input to the control board. The control board monitors the temperature anytime the liquid line solenoid valve is energized.

### **If the thermistor detects 123°F or higher for 15 continuous seconds:**

1. The ice machine will de-energize the liquid line solenoid and gear motor and initiate a SafeGuard.
2. The control board "Disch Temp" light will continue to flash twice then pause, to indicate the ice machine has shut off on high temperature.
3. The ice machine will remain off until the toggle switch is moved from ICE to OFF, and back to ICE.

**or**

Line voltage is interrupted and restored.

### **If the thermistor detects 30°F or less for 3 continuous minutes:**

1. The control board ignores the low temp. limit for the first 30 minutes of compressor run time.
2. The ice machine will de-energize the liquid line solenoid and gear motor, continuously flash the control board "Disch Temp" light and initiate a 60-minute Standby Mode.
3. After the 60-minute Standby Mode, the ice machine will de-energize the "Disch Temp" light and initiate a start-up sequence.
4. After 30 minutes of compressor run time, the ice machine will check the liquid line temperature.

### Liquid line temperature normal:

The ice machine continues to make ice.

### Liquid line temperature below 30°F after 30 minutes of run time:

The ice machine will start another 60-minute Standby Mode.

If the liquid line temperature drops below 30°F for 3 continuous minutes during 7 consecutive cycles the ice machine will start a SafeGuard Mode.

During the SafeGuard Mode the “Disch Temp” light will continually flash to indicate a Safeguard Mode.

The ice machine remains off until:

- The toggle switch is moved from ICE to OFF, then back to ICE.
- Line voltage is interrupted and restored.

### **Indicator Light**

Before 48 hours have elapsed:

After a Standby Mode has been initiated the “Disch Temp” light will flash anytime the toggle switch is placed in the OFF position.

After 48 hours have elapsed:

The SafeGuard will be automatically erased from memory and the “Disch Temp” light will not flash.

### **Temperature Sensor Checklist**

<b>Possible Problem List</b>	<b>Corrective Action List</b>
Thermistor is not properly insulated	Insulate thermistor.
Thermistor loose	Secure thermistor to liquid line.
Thermistor mounted in the wrong location	Position thermistor on liquid line between the heat exchanger and liquid line solenoid valve.
Thermistor defective	Refer to CHECK PROCEDURE under “Thermistor.”
Flooding expansion valve	Replace expansion valve.
Refrigerant overcharge or undercharge	Recover and weigh in nameplate charge.
Low ambient temperature	Verify ambient temperature remains above 45°F (7.2°C).
Defective compressor	Replace compressor.
Insufficient or low water pressure	Verify water pressure is between 20 and 80 psig.

# **SN012/SN020/SF0400/SN0450/SF0600/ SN0650/SF0900/SN0950/SF1200/SN1250**

## **SafeGuards**

- No Water
- No Ice Production

## **NO WATER**

The water sensing switch opens for more than 30 seconds.

## **Operation**

When the float switch is open at initial start-up the ice machine will wait for the switch to close before starting.

During the freeze cycle if the water float opens for 30 seconds the ice machine will:

1. De-energize the compressor and gearmotor.
2. The Water Ok light on the control board will de-energize.
3. A 5 minute delay is initiated.

The water Ok light will flash when the float switch recloses or when the toggle switch is placed in the OFF position.

The ice machine will remain off until the 5 minute delay period expires and the water float switch closes.

## **NO ICE PRODUCTION**

**SN012/SN020/SF0400/SN0450/SF0600/SN0650/  
SF0900/SN0950/SF1200/SN1250**

The ice damper did not open and close at least once every 90 seconds in the freeze cycle.

### OPERATION

During the first 8 minutes of operation:

The control board must see the ice damper open/close at least once. This allows time for ice production to start at all ambient temperatures

After the initial 8 minute period:

The control board must see the ice damper open/close at least once every 90 seconds.

When the ice damper does not open/close within the specified time the control board will:

1. De-energize the compressor and gearmotor.
2. HES #1 light on the control board will flash (the light will not flash if the ice damper is open).
3. A 5 minute delay is initiated.
4. After the 5 minute delay the ice machine will:
  - A. Energize the dump valve for 30 seconds
  - B. Energize the gearmotor
  - C. Wait until the water float valve closes and then energize the compressor and fan motor.
5. If the ice damper fails to open/close at least once in the initial 8 minute period, the control board will initiate another safety shutdown. This sequence will repeat until:
  - A. The ice machine restarts and operates normally for 10 minutes.
  - B. The ice machine is unable to run normally within 300 minutes of the initial shutdown.

If the ice machine does not run normally within 300 minutes of the initial shutdown, the control board will lock out and require a manual reset.

The control board will flash the HES #1 light anytime the toggle switch is placed in the off position for the first 48 hours after the failure.

## **Reset Procedure**

Move the ICE/OFF/CLEAN toggle switch from OFF to ICE or disconnect and reapply power to the ice machine.

## Diagnosing an Ice Machine That Will Not Run

QF0400/QC0700/QF0800/QF2200/QF2300

### Diagnosing An Ice Machine That Will Not Run



#### Warning

High (line) voltage is applied to the control board (terminals #21 and #23) at all times. Removing control board fuse or moving the toggle switch to OFF will not remove the power supplied to the control board.

QF2200/QF2300 - If the gearmotor is energized but no ice is produced, refer to “Diagnosing a Condensing Unit That Will Not Run”.

1. Verify primary voltage is supplied to ice machine and the fuse/circuit breaker is closed.
2. Verify control board fuse is okay. If any control board lights functions, the fuse is okay.
3. Verify the bin level control is connected to the control board and the bin level light is off.
4. Verify ICE/OFF/CLEAN toggle switch functions properly. Place the toggles switch in the ICE and CLEAN positions and check for energized components.
5. Verify low DC voltage is properly grounded. Loose DC wire connections may intermittently stop the ice machine.
6. Verify water is contacting the water level probes. The compressor (QF2300 liquid line solenoid valve) will not energize until water contacts the water level probes.

Be sure Steps 1-5 were followed thoroughly. Intermittent problems are not usually related to the control board.

## **RFC0985/RFC1285/RFC2085/RFC2385 DIAGNOSING A CONDENSING UNIT THAT WILL NOT RUN**

If the ice machine water pump is not energized refer to “Ice Machine Head Section Will Not Run”.

1. Verify primary voltage is supplied to ice machine condensing unit and the fuse/circuit breaker is closed.
2. Verify the high-pressure cutout and low-pressure (RFC2085 only) controls are closed. The HPCO and LPCO are closed if primary line voltage is present at the contactor coil terminals.
3. Verify line voltage is present at the contactor coil.
4. Verify the contactor contacts are closed and line voltage is present across all lines.
5. Refer to compressor diagnostics.



**QF0400/QC0700/QF0800/QF2200/QF2300 OPERATIONAL PROBLEM CHECKLIST**

<b>Problem</b>	<b>Possible Cause</b>	<b>To Correct</b>
Ice machine does not operate.	No electrical power to the ice machine.	Replace the fuse/reset the breaker/turn on the main switch/plug power cord into receptacle.
	Control board fuse open.	
	ICE/OFF/CLEAN toggle switch set improperly.	Move the toggle switch to the ICE position.
	8-minute lockout has not expired.	Bin Level light will flash to indicate 8-minute lockout has not expired. Refer to sequence of operation.
	Bin level sensor is disconnected or is contacting the ice.	Connect bin level sensor or remove ice contacting probe.
	High Pressure Control is open.	Clean condenser, check fan motor, check high pressure control operation.
Gear motor runs but compressor will not start.	Water reservoir is empty. (Water must contact the water level probes to start the compressor.)	Open water service valve or clean float valve screen.
	Water level probes out of position.	Correct water level probe position.
	Water float valve will not energize electrically.	Replace coil.
Remote Condenser Only	No electrical power to condensing unit.	Replace the fuse/reset the breaker/turn on the main switch.

Problem	Possible Cause	To Correct
Ice machine stops, and can be restarted by moving the toggle switch to OFF and back to ICE.	The SafeGuard feature is stopping the ice machine.	Refer to "SafeGuard Modes".
Ice quality is poor.	Poor incoming water quality.	Test the quality of the incoming water and check filter.
	Water filtration is poor.	Replace the filter.
	Water softener is working improperly (if applicable).	Repair the water softener.
	Incoming water supply temperature is above 90°F (32.2°C).	Correct water temperature (verify check/mixing valves in other equipment is working properly). Connect ice machine to a cold water supply.
	Water pressure is low	Water pressure must remain between 20 and 80 psig.

Problem	Possible Cause	To Correct
Low ice capacity.	Water float valve filter screen is dirty.	Remove and clean the filter screen.
	Incoming water supply is shut off.	Open the water service valve.
	Water float valve stuck open or leaking.	Remove the water float valve and clean it.
	The condenser is dirty.	Clean the condenser.
	High air temperature around ice machine (air-cooled models).	Air temperature must not exceed 110°F (43.3°C).
	Inadequate clearance around the ice machine.	Provide adequate clearance.
	Water dump valve is leaking.	Clean the dump valve.
	Objects stacked around ice machine, blocking airflow to condenser (air-cooled models).	Remove items blocking airflow.
	Incoming water supply temperature is above 90°F.	Connect ice machine to a cold water supply.
	Water Pressure is low.	Water Pressure must remain between 20 and 80 psig.

SN012/SN020/SF0400/SN0450/SF0600/SN0650/  
SF0900/SN0950/SF1200/SN1250

## Diagnosing An Ice Machine That Will Not Run



### Warning

High (line) voltage is applied to the control board (terminals #39 and #90) at all times. Removing control board fuse or moving the toggle switch to OFF will not remove the power supplied to the control board.

The following sequence describes the normal start up procedure for the ice machine when line voltage is disconnected then reconnected to the ice machine.

1. Power is supplied to the control board.
2. The control board lights race (energize/de-energize in sequence) to indicate the ice machine is in a 5 minute delay mode.
3. When the 5 minute delay ends the ice machine starts. The following lights are energized:
  - Nugget or Flaker depending on type of evaporator
  - HES #1
  - HES #2
  - Water OK

The HES #1 light will de-energize and re-energize as ice passes beneath the ice damper.

When the ice damper lifts approximately 45 degrees HES #2 de-energizes and the ice machine shuts off immediately on full bin. A 5 minute time delay is initiated, which prevents the ice machine from immediately restarting.

# Ice Machine Will Not Run

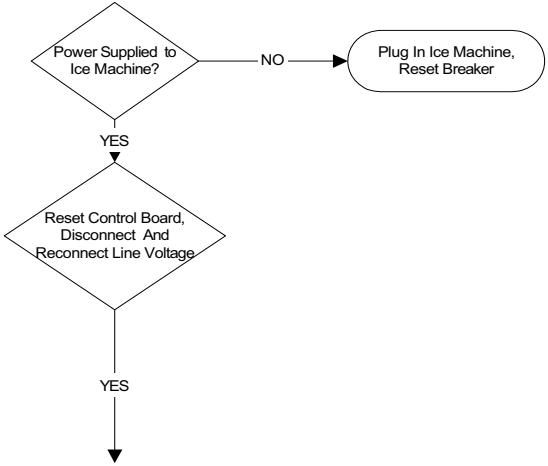

**IMPORTANT**  
A Five Minute Delay Initiates After The Problem Is Corrected. This Delay Must Expire Before The Ice Machine Will Start.

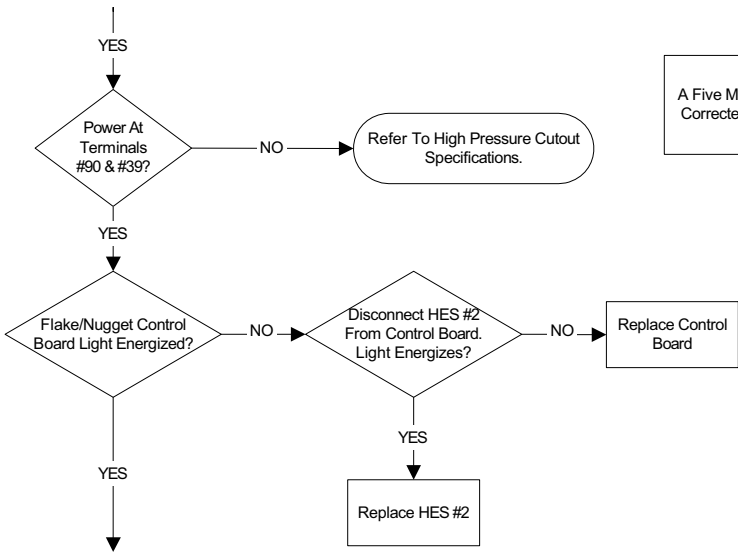

**IMPORTANT**  
A Five Minute Delay Initiates After The Problem Is Corrected. This Delay Must Expire Before The Ice Machine Will Start.

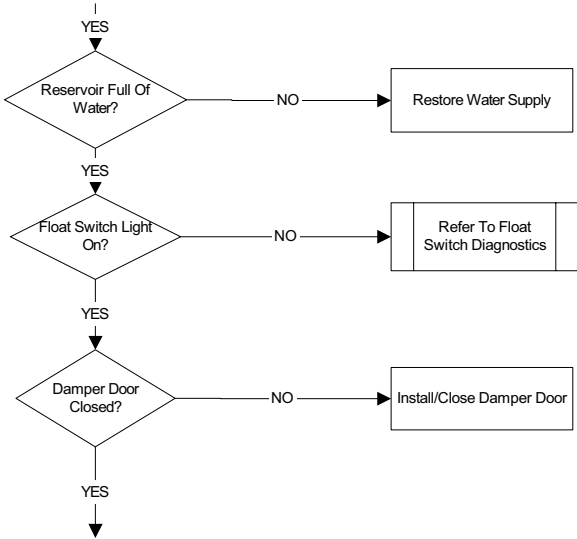

**IMPORTANT**  
A Five Minute Delay Initiates After The Problem Is Corrected. This Delay Must Expire Before The Ice Machine Will Start.

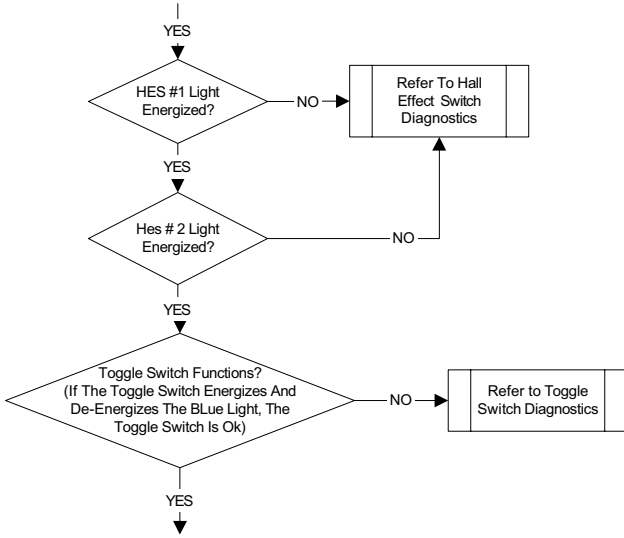
**IMPORTANT**

A Five Minute Delay Initiates After The Problem Is Corrected. This Delay Must Expire Before The Ice Machine Will Start.



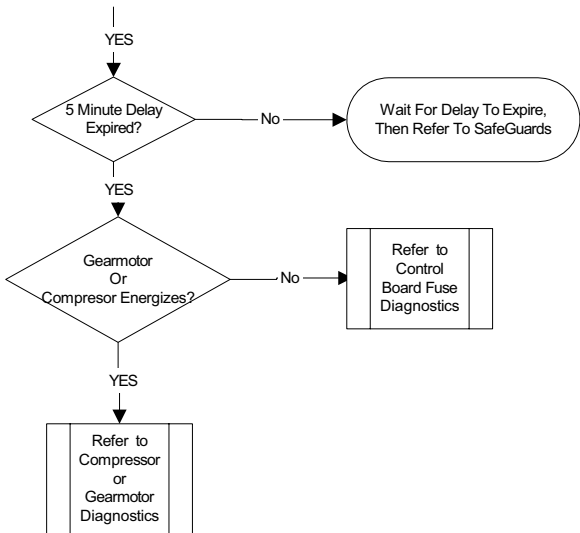

**IMPORTANT**  
A Five Minute Delay Initiates After The Problem Is Corrected. This Delay Must Expire Before The Ice Machine Will Start.

# Refrigeration Diagnostics

## BEFORE BEGINNING SERVICE

Ice machines may experience operational problems only during certain times of the day or night. A machine may function properly while it is being serviced, but malfunctions later. Information provided by the user can help the technician start in the right direction, and may be a determining factor in the final diagnosis.

Ask these questions before beginning service:

- When does the ice machine malfunction? (night, day, all the time, only during the Freeze cycle, etc.)
- When do you notice low ice production? (one day a week, every day, on weekends, etc.)
- Can you describe exactly what the ice machine seems to be doing?
- Has anyone been working on the ice machine?
- During “store shutdown,” is the circuit breaker, water supply or air temperature altered?
- Is there any reason why incoming water pressure might rise or drop substantially?

## INSTALLATION/VISUAL INSPECTION CHECKLIST

Possible Problem List	Corrective Action List
Filter and/or condenser is dirty.	Clean the filter and condenser.
Water filtration is plugged (if used).	Install a new water filter.
Water drains are not run separately and/or are not vented.	Run and vent drains according to the installation manual.

## WATER SYSTEM CHECKLIST

A water-related problem could cause component misdiagnosis.

Water system problems must be identified and eliminated prior to replacing other components.

<b>Possible Problem List</b>	<b>Corrective Action List</b>
Water area (evaporator) is dirty.	Clean as needed.
Water inlet pressure not between 20 and 80 psig.	Install a water regulator valve or increase the water pressure.
Incoming water temperature is not between 45°F (1.7°C) and 90°F (32.2°C).	If too hot, check the hot water line check valves in other store equipment.
Water filtration is plugged (if used).	Install a new water filter.
Vent tube is not installed on water outlet drain.	See installation instructions.
Hoses, fittings, etc., are leaking water.	Repair/replace as needed.
Water float valve is stuck open or closed.	Clean/replace as needed.
Dump valve is leaking.	Clean dump valve. Ice machine will shut off on Low Water SafeGuard.
Quick disconnect fitting is disconnected from the float valve.	Attach fitting to float valve.
Float valve outlet contacts float.	Adjust float valve outlet (see "Water Level Check").

## **ICE PRODUCTION/QUALITY CHECK**

### **QUALITY CHECK**

Ice quality will vary with ambient and water temperatures, and is measured by the amount of excess water in the ice. An easy test is to squeeze a handful of ice. High quality ice releases only a small amount of water. As ice quality drops, more water can be removed.

Generally speaking, higher incoming water temperature results in lower ice quality.

Lower water temperature results in higher ice quality.

### **ICE PRODUCTION CHECK**

1. Run the ice machine a minimum of 10 minutes to allow the system to stabilize.
2. Catch the ice in a non-perforated container for 7 minutes and 12 seconds or for more accuracy 14 minutes and 24 seconds.
3. Weigh the container and ice, then deduct the weight of the container.
4. Convert ounces to pounds.
5. Example: 3 lbs. 12 oz. converts to 3.75 lbs.
6. (12 oz. ÷ 16 oz. =.75 lb.)
7. Determine the 24-hour ice production capacity.
  - 7 minutes 12 seconds
  - Multiply the total ice weight by 200.
  - 14 minutes 24 seconds
  - Multiply the total ice weight by 100.

Example:

1. Collected ice for 7 minutes 12 seconds
2. Total weight (minus container) = 3.75 lbs.
3. 3.75 lbs. x 200 = 750 lbs. of ice every 24 hours
4. Compare the capacity to the 24-hour ice production chart for the model being tested.
5. Ice production checks that are within 10% of the charted capacity are considered normal due to variances in air and water temperatures. Actual temperatures will seldom match the chart exactly.

## ANALYZING DISCHARGE PRESSURE

1. Determine the ice machine operating conditions:
  - Air temperature entering condenser
  - Air temperature around ice machine
  - Water temperature entering water reservoir
2. Refer to 24-Hour Ice Production/Refrigeration Pressure Chart for ice machine being checked.

Use the operating conditions determined in step 1 to find the published normal discharge pressures and compare to actual discharge pressure readings.

3. Measure the actual discharge pressure.
4. Compare the actual discharge pressure (step 3) with the published discharge pressure (step 2).

The discharge pressure is normal when the actual pressure falls within the published pressure range for the ice machine's operating conditions.

### Discharge Pressure High Checklist

Problem	Cause
Improper installation	Refer to "Installation/Visual Inspection Checklist."
Restricted condenser air flow	Dirty air filter High inlet air temperature Condenser discharge air recirculation Dirty condenser fins Defective fan motor Defective fan cycle control
Improper refrigerant charge	Overcharged Non-condensable in system Wrong type of refrigerant
Other	Non-Manitowoc components in system High side refrigerant line/component restricted (before mid-condenser) Remote condenser or remote condensing units - Defective Head Pressure Control Valve

## Discharge Pressure Low Checklist

Problem	Cause
Improper installation	Refer to "Installation/Visual Inspection Checklist."
Improper refrigerant charge	Undercharged Wrong type of refrigerant
Other	Low ambient temperature Non-Manitowoc components in system High side refrigerant lines/component restricted (before mid-condenser) Suction pressure is too low and affecting discharge pressure. (Refer to "Suction Pressure Low Checklist.") No water or insufficient pressure Starving expansion valve Defective compressor Moisture in refrigeration system Defective fan cycle control Remote condenser or remote condensing units - Defective Head Pressure Control Valve

NOTE: Do not limit your diagnosis to only the items listed in the checklists.

## **ANALYZING SUCTION PRESSURE**

NOTE: Analyze discharge pressure before analyzing suction pressure.

High or low discharge pressure may be causing high or low suction pressure.

### **Suction Pressure High Checklist**

<b>Problem</b>	<b>Cause</b>
Improper installation	Refer to "Installation/Visual Inspection Checklist."
Discharge pressure	Discharge pressure is too high and is affecting suction pressure. Refer to "Discharge Pressure High Checklist."
Improper refrigerant charge	Overcharged Wrong type of refrigerant Non condensables in system
Other	Dump valve leaking Non-Manitowoc components in system TXV flooding (check bulb mounting and insulation). Defective compressor

## Suction Pressure Low Checklist

<b>Problem</b>	<b>Cause</b>
Improper installation	Refer to "Installation/Visual Inspection Checklist."
Discharge pressure	Discharge pressure is too low and is affecting suction pressure. Refer to "Discharge Pressure Low Checklist."
Improper refrigerant charge	Undercharged Wrong type of refrigerant
Other	Non-Manitowoc components in system Restricted/plugged liquid line drier Restricted/plugged tubing in suction side of refrigeration system Expansion valve starving No water or insufficient pressure Moisture in refrigeration system Dirty Evaporator Defective Fan Cycle Control Remote condenser or remote condensing units - Defective Head Pressure Control
<b>NOTE: Do not limit your diagnosis to only the items listed in the checklists</b>	



# Component Check Procedures

---

## QF0400/QC0700/QF0800/QF2200/QF2300

### MAIN FUSE

#### FUNCTION

The control board fuse stops ice machine operation if electrical components fail, causing high amp draw.

#### SPECIFICATIONS

The main fuse is 250 Volt, 10 amp, time delay.



### Warning

High (line) voltage is applied to the control board at all times. Removing the control board fuse or moving the toggle switch to OFF will not remove the power supplied to the control board.

#### CHECK PROCEDURE

1. Energized control board lights do not indicate a good fuse.



### Warning

Disconnect electrical power to the entire ice machine before proceeding.

2. Remove the fuse. Check for continuity across the fuse with an ohmmeter.

Reading	Result
Open (OL)	Replace fuse
Closed (O)	Fuse is good

## ICE/OFF/CLEAN TOGGLE SWITCH

QF0400/QC0700/QF0800/QF2200/QF2300

### FUNCTION

The switch is used to place the ice machine in ICE, OFF or CLEAN mode of operation.

### SPECIFICATIONS

Single-pole, double-throw switch. The switch is connected into a varying low DC voltage circuit.

### CHECK PROCEDURE

NOTE: Because of a wide variation in DC voltage, it is not recommended that a volt meter be used to check toggle switch operation.

1. Inspect the toggle switch for correct wiring.
2. Isolate the toggle switch by disconnecting all wires from the switch, or by disconnecting the Molex connector from the control board.
3. Check across the toggle switch terminals using a calibrated ohm meter. Note where the wire numbers are connected to the switch terminals, or refer to the wiring diagram to take proper readings.

Switch Setting	Terminals	Ohm Reading
ICE	19 – 20	Closed
	19 – 23	Open
	20 – 23	Open
CLEAN	19 – 20	Open
	19 – 23	Closed
	20 – 23	Open
OFF	19 – 20	Open
	19 – 23	Open
	20 – 23	Open

Replace the toggle switch if ohm readings do not match all three switch settings.

## **WATER FLOAT VALVE**

**QF0400/QC0700/QF0800/QF2200/QF2300**

### FUNCTION

The float valve maintains correct water level during the Freeze cycle.

It allows the evaporator to drain completely during the Automatic Shut-Off cycle.

### CHECK PROCEDURE

1. Verify water is supplied to the float valve, the water inlet screen is clean, and the float and float arm are free moving.
2. Refer to the Energized Parts Chart and verify the following:
  - The float valve coil should be energized.
  - The red water valve LED on the control board is energized.
3. Check for line voltage at float valve coil. This test must be performed within 90 seconds of the water float valve energizing. If no water contacts the water level probes within 90 seconds, the valve will de-energize.

<b>Step 3 Check for Line Voltage</b>	
<b>Voltage Reading</b>	<b>Result</b>
Line Voltage	Replace Solenoid Coil or Replace Valve
No Voltage	See "Control Board Relays" for further diagnostics.

## WATER LEVEL CHECK

### QF0400/QC0700/QF0800/QF2200/QF2300

The float valve maintains the correct water level. The water level must allow the water level probes to maintain water contact throughout the Freeze cycle. The water level is factory set and normally will not require adjustment. Check the water level during the Freeze cycle. The water level is correct if the Water Level indicator light is energized and no water is entering the overflow tube. (Check for overflow water exiting the ice machine drain line at the floor drain.)

If adjustments are necessary:

- A. Rotate float clockwise to increase water level.
- B. Rotate float counterclockwise to decrease water level.

Verify the outlet for the water float valve is at a 20° to 30° angle to prevent contact with the float.

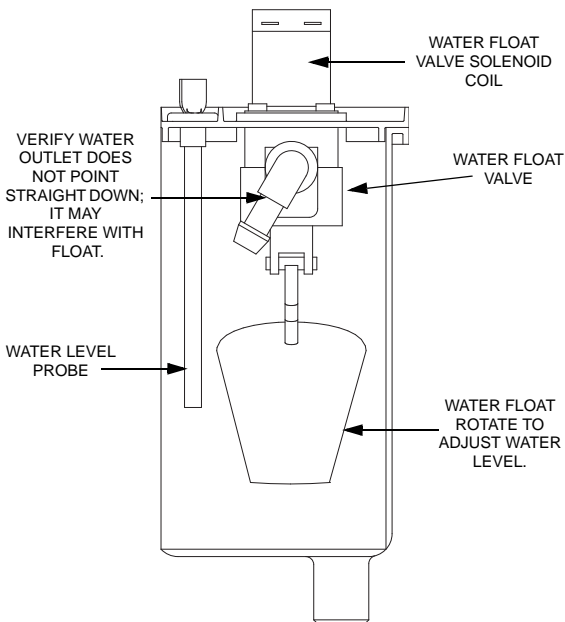

## **BIN LEVEL PROBE DIAGNOSTICS**

**QF0400/QC0700/QF0800/QF2200/QF2300**

### **FUNCTION**

The bin level probe shuts off the ice machine after the bin fills with ice.

To start ice making, the bin level probe must be open (Bin Level light off). If the probe is closed (Bin Level light on) when the toggle switch is moved to ICE, the control system waits until the bin level probe opens (Bin Level light off) before starting an ice making sequence. If the bin level probe is disconnected from the circuit board, the ice machine will not start. This prevents overfilling the bin with ice.

### **FAILURE MODES**

#### **Bin Level Probe Open or Disconnected**

The ice machine will not start and continuously flashes the Bin Level light. Opening the bin level probe for 15 continuous seconds in the Freeze cycle will initiate an Automatic Shut-Off sequence.

#### **Bin Level Probe Closed or Shorted**

The ice machine will not start and the Bin Level light is energized.

Shorting the probe for 30 continuous seconds in the Freeze cycle will initiate an Automatic Shut-Off sequence.

### **CHECK PROCEDURE**

#### **Bin Level Probe Open or Disconnected**

The ice machine will not start and continuously flashes the Bin Level light.

1. Move toggle switch from OFF to ICE to OFF to ICE to verify ice machine is not in an 8-minute lockout.

<b>Control Board Bin Level Light</b>	<b>Cause</b>
Off	Ice machine was in an Automatic Shut-Off mode (8-minute lockout).
Flashes	Go to step 2.

2. Disconnect bin level probe from control board and check continuity (ohms) from the female connector to the bin level probe.

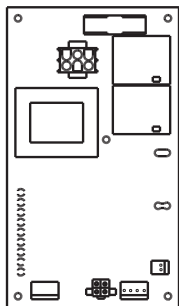

CHECK FOR CONTINUITY  
CONNECTOR TO PROBE.

Continuity	Cause
No	Replace bin level probe.
Yes	Go to step 3.

- Remove bin level probe from ice chute and clean with Manitowoc Ice Machine Cleaner and Sanitizer. Rinse well with fresh water, reinstall and monitor the Bin light.

<b>Control Board Bin Level Light</b>	<b>Cause</b>
Off	Bin level probe needed cleaning.
Flashes	Go to step 4.

- Disconnect bin level probe wire from the control board and place a jumper from the bin level terminal to ground.

<b>Control Board Bin Level Light</b>	<b>Cause</b>
On	Replace bin level probe.
Flashes	Reconfirm control board is not in an 8-minute lockout. Repeat steps 1 – 4, then replace control board.

## Bin Level Probe Closed or Shorted

The ice machine will not start and the Bin Level light is energized continuously.

1. Verify ice is not in contact with bin level probe.
2. Disconnect bin level probe wire from the control board.

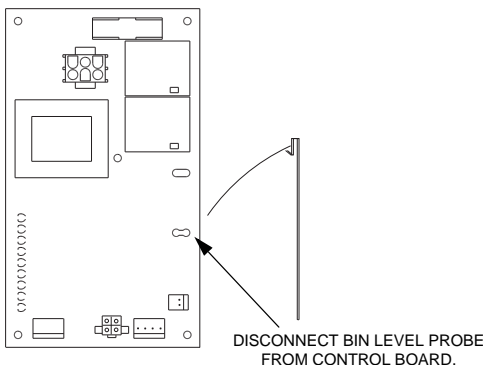

Control Board Bin Level Light	Cause
Off	Clean bin level probe.
On	Replace control board.



## **WATER LEVEL PROBES**

**QF0400/QC0700/QF0800/QF2200/QF2300**

### FUNCTION

The water level probe protects the compressor if water is not detected.

Water contacting the probes will complete the circuit and energize the Water Level Probe light.

There are two water level probes; one probe is connected to the circuit board and one probe is connected to the ice machine ground.

Water level probe operation can be determined by watching the Water Level Probe light. The Water Level Probe light is on when water contacts the probe, and off when no water is in contact with the probe. The Water Level Probe light functions any time power is applied to the ice machine, regardless of toggle switch position.

During the Water Fill and Freeze cycle, the water level probe monitors the water level. The water float valve maintains the correct water level. If the water level is incorrect, refer to "Water Float Valve."

### FAILURE MODES

#### **Water Level Probe Open or Disconnected (Ice machine will not start compressor.)**

Performs initial start-up procedure. Ninety seconds after ice machine enters Water Fill (1B), the ice machine will initiate an Automatic Shut-Off cycle, flash the Water Level Probe light and remain off for 60 minutes. (Refer to "No Water" SafeGuard for additional information.)

## Water Level Probe Closed or Shorted (Ice machine will continue to run.)

If the ice machine runs out of water with the water level probe shorted, the ice machine will initiate an Automatic Shut-Off cycle and flash the Temperature light. (Refer to “High or Low Temperature SafeGuard” for additional information.)

### CHECK PROCEDURE

#### Water Level Probe Open or Disconnected

1. Determine which water level probe is connected to “water level” on the control board.
2. Remove water level probe from reservoir and place jumper wire from the water level probe to ground.
3. Move the toggle switch to the ICE position, wait 45 seconds, and then monitor the Water Level Probe light.

Step 3 Jumper water level probe to ground		
Water Level light is:	Compressor	Cause
On	Energizes	Control system is operating normally Verify water level is correct.
Off	Remains de-energized	Proceed to step 4.

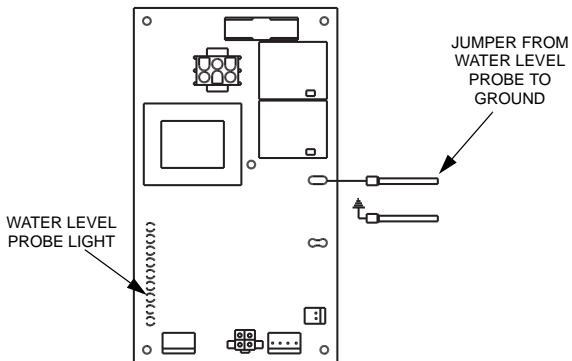

4. Disconnect water level probe from control board. Install jumper from control board "water level" terminal to ground.
5. Move the toggle switch from ICE to OFF to ICE position. Wait 45 seconds, then monitor the Water Level Probe light.

Step 5 Jumper "water level" terminal to ground		
Water Level light is:	Compressor	Cause
On	Energizes	Replace water level probe wiring. (Verify defective component – ohm wire from connector to connector.)
Off	Remains de-energized	Replace control board.

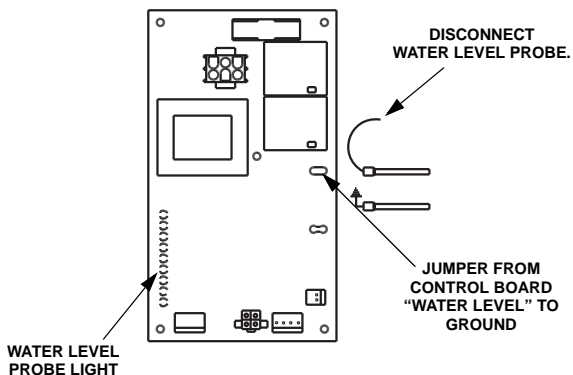

## Water Level Probe Closed or Shorted

1. Disconnect the water level probe from the control board.
2. Move the toggle switch to the ICE position, wait 45 seconds and then monitor the Water Level Probe light.

Step 2 Disconnect water level probe from control board "water level" terminal		
Water Level light is:	Compressor	Cause
Off	Remains de-energized	Clean water level probe.
On	Energizes	Replace control board.

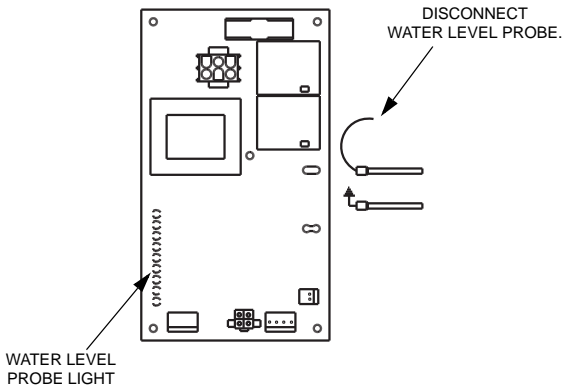

## **MOTOR SPEED SENSOR**

**QF0400/QC0700/QF0800/QF2200/QF2300**

### FUNCTION

The motor speed sensor verifies that the gearbox motor is rotating at the correct speed.

### FAILURE MODES

#### **Motor Speed Sensor Open or Disconnected (Ice machine will not start.)**

Performs initial start-up procedure. Ten to 15 seconds after the ice machine enters Water Flush (1), the ice machine will initiate an Automatic Shut-Off cycle, flash the Speed light and remain off for 60 minutes. (Refer to "Gear Motor Speed" for additional information.)

#### **Motor Speed Sensor Closed or Shorted (Ice machine will not start.)**

Performs initial start-up procedure. Ten to 15 seconds after the ice machine enters Water Flush (1), the ice machine will initiate an Automatic Shut-Off cycle, flash the Speed light and remain off for 60 minutes. (Refer to "Gear Motor Speed" for additional information.)

### CHECK PROCEDURE

1. Allow time for the evaporator to warm.  
Disconnecting power in the Freeze cycle will result in ice build-up between the evaporator and auger.
2. Verify the motor speed sensor is in place and securely attached to the motor.
3. Verify the gearmotor run capacitor is functional.
4. Place toggle switch in the OFF position and place an identifying mark on the evaporator/gearbox coupling. This will provide a reference point to verify the coupler is rotating.
5. Move the toggle switch to the ICE position and verify the motor shaft and coupling are turning, then observe the Speed light. (If the gear motor and coupling will not rotate, the switch is operating correctly.)

<b>Speed light is:</b>	<b>Cause</b>
On after 3 to 5 seconds	This is normal operation.
Off	Replace motor speed sensor.
On after 3 to 5 seconds and control board terminates Freeze cycle	Replace control board.

To verify coupling/auger RPM (revolutions per minute):

1. Verify line voltage is within 10% of ice machine nameplate rating when low RPM is suspected.
2. Verify the gear motor run capacitor is functional.
3. Place identifying mark on coupling.
4. Count coupling revolutions for 2 minutes.
5. Divide coupling revolutions by 2 (example:  
31 coupling revolutions  $\div$  2 = 15-1/2 RPM).

Minimum revolutions per minute:

- QF0400 = 9 RPM
- QC0700 = 15 RPM
- QF0800 = 15 RPM
- QF2200/QF2300 = 11.6 RPM

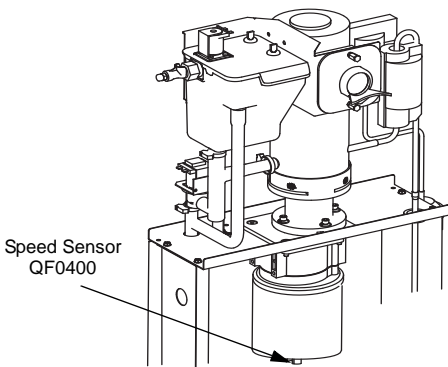

## TEMPERATURE SENSOR

**QF0400/QC0700/QF0800/QF2200/QF2300**

### FUNCTION

The temperature sensor provides input to the control board. The control board monitors the temperature anytime the liquid line solenoid valve or compressor is energized. When a temperature is sensed that is above or below the correct temperature range, the ice machine de-energizes.

### TEMPERATURE RANGES:

QF0400/QC0700/QF0800 155°F to 255°F  
(68°C to 124°C)

QF2200 30°F to 123°F (-1°C to 51°C)

Specifications

10,000 Ohms at 77°F (25°C)

### **Caution**

Use only Manitowoc thermistors.

### CHECK PROCEDURE

The thermistor must be securely attached and insulated to operate properly.

Verify that the thermistor resistance is accurate and corresponding to the high and low temperature ranges.

1. Disconnect the thermistor at the control board. Connect the ohmmeter to the isolated thermistor wire leads.
2. Using a temperature meter capable of taking readings on curved copper lines, attach the temperature meter-sensing device to the refrigeration line next to the thermistor.

### **Important**

Do not simply "insert" the sensing device under the insulation. It must be attached to and reading the actual temperature of the discharge line.

- With the ice machine running, verify that the temperature of the refrigeration line (step 2) corresponds to the thermistor resistance reading (step 1) as stated in the temperature/resistance chart.

### Temperature/Resistance Chart

As the temperature rises at the thermistor block, the resistance drops.

#### Important

If the ohmmeter reads "OL," check the scale setting on the meter before assuming the thermistor is bad.

Temperature of Thermistor		Resistance K Ohms (x 1000)
°C	°F	
-17.77° – -12.22°	0° – 10°	85.35 – 62.46
-12.22° – -6.66°	10° – 20°	62.46 – 46.22
-6.66° – -1.11°	20° – 30°	46.22 – 34.56
-1.11° – 4.44°	30° – 40°	34.56 – 26.10
4.44° – 10.0°	40° – 50°	26.10 – 19.90
10.0° – 15.55°	50° – 60°	19.90 – 15.31
15.6° – 21.1°	60° – 70°	15.31 – 11.88
21.1° – 26.7°	70° – 80°	11.88 – 9.29
26.7° – 32.2°	80° – 90°	9.29 – 7.33
32.2° – 37.8°	90° – 100°	7.33 – 5.82
37.8° – 43.3°	100° – 110°	5.82 – 4.66
43.3° – 48.9°	110° – 120°	4.66 – 3.75
48.9° – 54.4°	120° – 130°	3.75 – 3.05
54.4° – 60.0°	130° – 140°	3.05 – 2.49
60.0° – 65.6°	140° – 150°	2.49 – 2.04
65.6° – 71.1°	150° – 160°	2.04 – 1.68
71.1° – 76.7°	160° – 170°	1.68 – 1.40
76.7° – 82.2°	170° – 180°	1.40 – 1.17
82.2° – 87.8°	180° – 190°	1.17 – 0.98
87.8° – 93.3°	190° – 200°	0.98 – 0.82
93.3° – 98.9°	200° – 210°	0.82 – 0.70
104.4° – 110.0°	220° – 230°	0.59 – 0.51
110.0° – 115.6°	230° – 240°	0.51 – 0.43
115.6° – 121.1°	240° – 250°	0.43 – 0.37
121.1° – 126.7°	250° – 260°	0.37 – 0.33



## QF2200 Only

### LOW PRESSURE CUT-OUT CONTROL

#### RFC2085 (QF2200) Only

#### FUNCTION

Energizes and de-energizes the contactor coil when suction pressure rises above or falls below setpoint.

The LPCO control is closed at pressures above setpoint and opens at pressures below setpoint.

#### SPECIFICATIONS

Model	Cut-In (Close)	Cut-Out (Open)
RFC2085	22 psig $\pm$ 3	7 psig $\pm$ 3

#### CHECK PROCEDURE

1. Connect manifold gauges at suction and discharge access valves at the condensing unit.
2. Set ICE/OFF/CLEAN switch to OFF.
3. The liquid line solenoid valve will de-energize and the suction pressure will begin to decrease. The low-pressure control will open at the listed specification.
4. Use the manifold gauge set to increase suction pressure. Feed refrigerant from the high side access valve to the low side access valve. Add refrigerant in small increments to allow the low side pressure to be monitored. The low pressure control will close at the listed specification.

Replace the LPCO control if it:

- Will not close at the specified set point.
- Does not open at the specified set point.

## **QF2300 Only**

### **EQUALIZATION VALVE**

#### **GENERAL**

The equalization valve is an electrically operated valve that closes when energized, and opens when de-energized.

#### **NORMAL OPERATION**

The valve is energized (closed) during the freeze cycle and de-energized (open) during the off cycle. The valve equalizes low and high side pressure during the off cycle.

#### **ANALYSIS**

The valve can fail in two positions:

- Valve will not open in the off cycle.
- Valve remains open during the freeze cycle.

#### **VALVE WILL NOT OPEN IN THE OFF CYCLE**

Discharge and suction pressure will not equalize.

#### **VALVE REMAINS OPEN IN THE FREEZE CYCLE:**

Symptoms of a equalization valve remaining partially open during the freeze cycle can be similar to symptoms of an expansion valve or compressor problem. Symptoms are dependent on the amount of leakage in the freeze cycle.

A small amount of leakage will result in poor quality ice. As the size of the leak increases ice quantity will decrease until ice production stops completely.

A small amount of leakage will cause an audible indication as the vapor passes through the valve. As the size of the leak increases the audible indication becomes more apparent.

Refer to the Parts Manual for proper valve application. When replacement is necessary, use only “original” Manitowoc replacement parts.

## ELECTRONIC BIN THERMOSTAT

### QF2300 Only

The temperature control opens the bin switch (or toggle switch) circuit when ice contacts the sensor. When ice no longer contacts the sensor, the circuit closes and the ice machine starts.

### Specifications

Setpoint Range: -30 to 212°F (-34 - 100°C)

### Control Settings

Verify control is set properly before proceeding.

Display	Function	Preset Settings
SP	Set Point	40
DIF	Differential	1
ASD	Anti-Short Cycle Delay	1
OFS	Temperature Offset	0
SF	Sensor Failure Mode	0 - Nugget/Flake/Chiplet

### Positioning the Touch pad Jumpers

#### P5 JUMPER

The P5 jumper position determines if the touch pad is locked or unlocked. The control is factory locked; to unlock move the jumper from one pin to two pins.

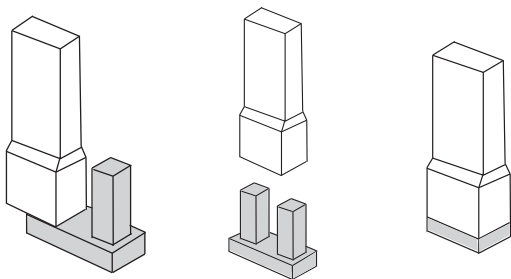

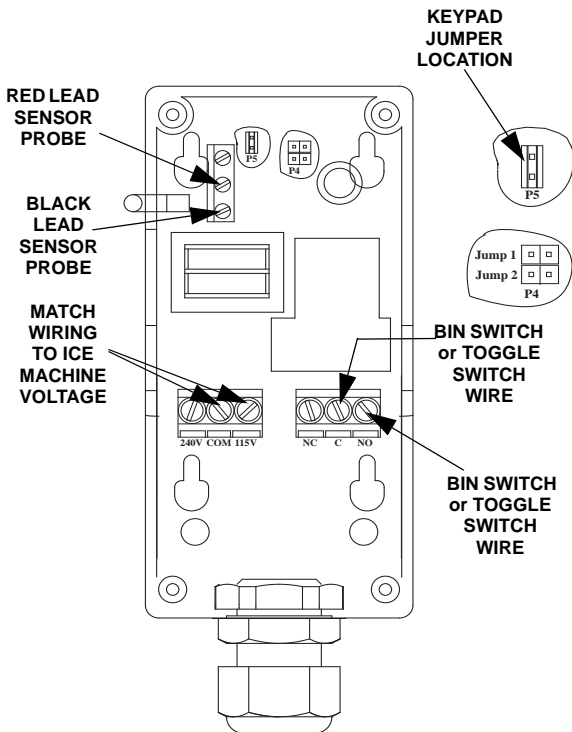

**Inside of Bin Thermostat Control**

### **P4 JUMPER**

The P4 jumper labeled Jump 1 is used to set the control for heating or cooling mode. Jump 2 is used to establish Setpoint at either cut-in or cutout.

### **Cooling Mode Cut-Out at Setpoint**

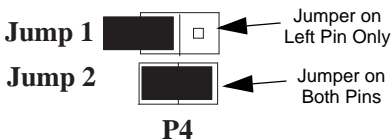

## Setting Control Setpoint Value

To view and adjust setpoint, follow these steps:

1. Press MENU until the display flashes SP.
2. Press MENU again to display the existing setpoint value.
3. Press Up or Down (arrows) to change the setpoint value.
4. Press MENU again to save the new value. The display returns to the sensed temperature.

NOTE: If no setup entry is made for 30 seconds, the control reverts to the normal temperature display.

### Important

If MENU is not pressed after changing the setpoint value, the control reverts to the previously programmed setpoint value.

## Differential, Anti-Short Cycle Delay, Temperature Offset, or Sensor Failure Operation

To set or verify the Differential, Anti-Short Cycle Delay, Temperature Offset or Sensor Failure Operation use the following method.

1. Factory Preset Temperature Control Code Settings as follows:
2. Press and hold MENU until the display changes to flashing SP.
3. Press up and down (arrows) repeatedly until the desired function is displayed.
4. Press MENU to display the function's current value.
5. Press up and down (arrows) until the desired value is displayed.
6. Press MENU to save the new value. The display returns to the sensor temperature.

NOTE: If no setup entry is made for 30 seconds, the control reverts to the temperature display.

NOTE: Any saved control settings are non-volatile and remain in the control's memory during power interruptions.

## Check Procedure

### **Warning**

Line voltage is present inside control. Contact with line voltage can cause serious injury or death.

If the control system does not function properly, verify that the control is wired and set up properly. If the problem persists use the following procedures to determine the cause of the problem.

1. Check the proper voltage to the control.
  - A. Remove the cover, loosen the four cover screws.
  - B. Use an AC voltmeter to check the voltage between the common and 120V or 240V terminals.
  - C. The voltage must be between 102 and 132 volts for 120V applications, 177 and 264 volts for 208/230V applications.
  - D. If the voltage reading is not within the required range, check the power source and input power wires for problems.

### 2. Fault Codes

If the LCD displays an alarm or fault code (SF or EE):

<b>Fault Code</b>	<b>Definition</b>	<b>Solution</b>
SF flashing alternately with OP	Open temperature sensor or sensor wiring	See Step 3. Cycle power to reset control.
SF flashing alternately with SH	Shorted temperature sensor or sensor wiring	See Step 3. Cycle power to reset control.
EE	Program failure	Reset the control by pressing MENU. If problem persists, replace the control.

3. Check for proper operation.

NOTE: Perform Steps 1 and 2 before performing this step.

- A. Disconnect the load from the output relay terminals.
- B. Reconnect the sensor leads and supply power to the control.
- C. Replace the cover.
- D. Check the control settings for proper values.
- E. Press and hold MENU until SP appears.
- F. Press up and down (arrows) to change the setpoint temperature above and below the sensor temperature until the relay energizes and de-energizes.
- G. If the output relay does not perform as indicated replace the control.
- H. If proper operation of the control is verified, reconnect the load.

# S Model Nugget/Flake

## MAIN FUSE

### FUNCTION

The control board fuse stops ice machine operation if electrical components fail, causing high amp draw.

### SPECIFICATIONS

The main fuse is 250 Volt, 10 amp, time delay.

#### **Warning**

High (line) voltage is applied to the control board at all times. Removing the control board fuse or moving the toggle switch to OFF will not remove the power supplied to the control board.

### CHECK PROCEDURE

1. Energized control board lights do not indicate a good fuse.

#### **Warning**

Disconnect electrical power to the entire ice machine before proceeding.

2. Remove the fuse. Check for continuity across the fuse with an ohmmeter.

Reading	Result
Open (OL)	Replace fuse
Closed (O)	Fuse is good



## ICE/OFF/CLEAN TOGGLE SWITCH

### S Models

#### FUNCTION

The switch is used to place the ice machine in ICE, OFF or CLEAN mode of operation.

#### SPECIFICATIONS

Single-pole, double-throw switch. The switch is connected into a varying low D.C. voltage circuit.

#### CHECK PROCEDURE

**NOTE:** Because of a wide variation in D.C. voltage, it is not recommended that a voltmeter be used to check toggle switch operation.

1. Inspect the toggle switch for correct wiring.
2. Isolate the toggle switch by disconnecting the Molex connector.
3. Check continuity across the toggle switch terminals. Note where the wire numbers are connected to the switch terminals, or refer to the wiring diagram to take proper readings.

Switch Setting	Terminals	Ohm Reading
ICE	1-6	Open
	1-2	Closed
	2-6	Open
CLEAN	1-6	Closed
	1-2	Open
	2-6	Open
OFF	1-6	Open
	1-2	Open
	2-6	Open

4. Replace the toggle switch if continuity readings do not match all three switch settings.

## **FLOAT SWITCH**

### **FUNCTION**

The float switch prevents the ice machine from running when the water level is below the control setpoint.

The float switch must be closed (float in up position) before the ice machine will start, and must remain closed throughout the freeze cycle.

### **SPECIFICATIONS**

A mechanical liquid level sensor, that magnetically operates a reed switch.

### **CHECK PROCEDURE**

**NOTE:** The water float switch is connected to the water reservoir cover. The reservoir cover must be in place and water must be present in the reservoir to close the switch. Verify water is supplied to the float valve, the water inlet screen is clean, and the float and float arm are free moving.

1. Disconnect power to the ice machine.
2. Disconnect the float switch from the control board and connect an ohm meter to the switch wires.
3. Verify the switch is in the up position (reservoir full of water), then check continuity.

<b>Step 3 Check for Continuity</b>	
<b>Reading</b>	<b>Result</b>
Closed	The switch is working properly
Open	Replace the switch

4. Remove cover from reservoir by lifting straight up. Verify the switch opens as the float drops.

## **ICE DAMPER AND HALL EFFECT SWITCHES**

### **Damper Door**

#### **FUNCTION**

Opens and closes as ice passes from the ice chute to the bin. A metal lever attached to the damper interrupts the magnetic field sensed by the hall effect switches as the damper opens and closes.

#### **Hall Effect Switch #1 - Operational Sensing**

This switch will open and re-close in conjunction with the ice damper as ice is discharged from the evaporator. The control board must see this switch open and close at least once every 90 seconds during the freeze cycle.

#### **Hall Effect Switch #2 - Shut-Off and Restart**

This switch also works in conjunction with the ice damper. When the switch opens, the ice machine stops immediately. The ice machine restarts when the switch re-closes and the five minute delay period expires.

#### **FUNCTION TEST**

Place toggle switch in OFF position. HES#1 and HES#2 lights will energize. Move ice damper slowly to open position.

- HES#1 light de-energizes, HES#2 remains energized.
- HES#2 light de-energizes as damper continues to open.

Move damper slowly to closed position HES#2 energizes, HES#1 remains de-energized.

HES#1 energizes as the damper continues to close.

## Hall Effect Switch Diagnostics

All diagnostics must be performed with the ice damper installed and in the closed position. The control board lights will not indicate as described below with the ice damper in the open position. The ice damper must swing freely, if the damper is binding adjust/loosen screws that hold the Hall Effect Switch Housing in place.

### SWITCH FAILS OPEN OR IS DISCONNECTED

#### HES#1

1. Reset line voltage to the ice machine
2. Wait 5 minutes for delay to expire.
3. HES#1 light energizes and ice machine starts.
4. When 5 minute delay period ends the ice machine shuts off and flashes the HES#1 light.

#### HES#2

1. Reset line voltage to the ice machine.
2. Wait 5 minutes for delay to expire.
3. HES#2 light is energized and HES#1 light is de-energized.
4. Ice machine starts.
5. After 5 minutes the ice machine shuts off. HES#1 is de-energized and HES#2 is energized.

## SWITCH FAILS CLOSED

### HES#1

1. Reset line voltage to the ice machine
2. Wait 5 minutes for delay to expire.
3. HES#1 light de-energized.
4. The ice machine starts, runs for 20 seconds, then de-energizes.
5. HES#1 light is de-energized.

### HES#2

1. Reset line voltage to the ice machine
2. Wait 5 minutes for delay to expire.

HES #2 is a three wire switch and can stop in three separate failure modes.

- HES #1 is energized, HES #2 is de-energized, the ice machine will not start.
- HES #1 and HES #2 lights are de-energized, the ice machine will not start.
- HES #1 and HES #2 are energized. The ice machine starts, immediately shuts off and starts another 5 minute delay period (control board lights race to indicate 5 minute delay period). The ice machine will repeat the sequence until the toggle switch is moved to OFF or power is disconnected to the ice machine.

In all failure modes disconnecting HES #2 from the control board will result in Switch Fails Open or is Disconnected symptoms (see previous page).

## SN012/SN020 Only

### SELECTOR SWITCH

#### FUNCTION

Selects product dispensed. Ice, Water or Ice and Water.

#### CHECK

1. Inspect the selector switch for correct wiring.
2. Isolate the switch by disconnecting all wires from the switch.
3. Check resistance across the switch terminals with an ohm meter.

Switch Setting	Terminals	Resistance Reading
<b>ICE</b>	L1 - A	Closed
	L1 - B	Open
	L1 - L3	Open
	L1 - C	Open
	L3 - C	Open
<b>WATER</b>	L1 - A	Open
	L1 - B	Closed
	L1 - L3	Open
	L1 - C	Open
	L3 - C	Open
<b>WATER AND ICE</b>	L1 - A	Open
	L1 - B	Closed
	L1 - L3	Open
	L1 - C	Open
	L3 - C	Closed

Replace the selector switch if ohm readings do not match all three switch settings.

## **DISPENSE SWITCH**

### **FUNCTION**

Supplies power to the product selector switch when activation lever is depressed.

### **CHECK**

1. Inspect the selector switch for correct wiring.
2. Isolate the switch by disconnecting all wires from the switch.
3. Check across the switch terminals with an ohm meter.

<b>Activation Lever Position</b>	<b>Resistance Reading</b>
Depressed	Closed
Released	Open

Replace the selector switch if ohm readings do not match.

## **TOUCHLESS SENSOR**

### **FUNCTION**

Supplies power to the product selector switch when container activates sensor.

### **CHECK**

Container must be within an inch of sensor to activate.

### **Will Not Dispense**

1. Verify power is supplied to the ice machine. When the toggle switch is in ICE position the blue LED light will be on.
2. Disconnect wires from C (common) and NO (normally open) terminals on the sensor control board.
3. Use an ohm meter to verify the switch is opening and closing. Place hand in front of sensor, if the sensor activates and closes the switch the sensor is working correctly.
4. If the sensor does not activate disconnect the sensor wire from the sensor control board. Short +5 and SIG.
  - If the contacts close replace the sensor.
  - If the contacts remain open replace the sensor control board.

### **Will Not Stop Dispensing**

1. Disconnect sensor plug from sensor control board.
  - If the dispensing stops, replace the sensor.
2. If the dispensing continues disconnect wires 22 & 59/60 from the control board.
3. Check resistance across control board contacts.
  - Closed = Replace the sensor control board
  - Open = Refer to selector switch diagnostics.



## All Models

### HIGH PRESSURE CUTOUT CONTROL FUNCTION

Stops the ice machine if subjected to excessive high-side pressure.

The HPCO control is normally closed, and opens on a rise in discharge pressure.

Specifications	
Cut-Out	Cut-In
450 psig $\pm$ 10 (3103 kPa $\pm$ 69) 31 bar $\pm$ .69	Automatic Reset
(Must be below 300 psig (2068 kPa 20.68 bar) to reset.)	

### CHECK PROCEDURE

1. Set ICE/OFF/CLEAN switch to OFF, (Manual reset HPCO reset if tripped).
2. Disconnect main power supply to the ice machine.
3. Connect manifold gauges to the access valves.
4. Hook voltmeter in parallel across the HPCO, leaving wires attached.
5. Reconnect main power supply to the ice machine.

6. Set ICE/OFF/CLEAN switch to ICE.
7. No water or air flowing through the condenser will cause the HPCO control to open because of excessive pressure. Watch the pressure gauge and record the cut-out pressure.



### **Warning**

If discharge pressure exceeds 460 psig (3172 kPa 31.72 bar) and the HPCO control does not cut out, set ICE/OFF/CLEAN switch to OFF to stop ice machine operation.

Replace the HPCO control if it:

8. Will not reset [below 300 psig (2068 kPa 20.68 bar)].
9. Does not open at the specified cut-out point.

## COMPRESSOR ELECTRICAL DIAGNOSTICS

The compressor does not start or will trip repeatedly on overload.

### Check Resistance (Ohm) Values

**NOTE:** Compressor windings can have very low ohm values. Use a properly calibrated meter.

Perform the resistance test after the compressor cools. The compressor dome should be cool enough to touch (below 120°F/49°C) to assure that the overload is closed and the resistance readings will be accurate.

### SINGLE PHASE COMPRESSORS

1. Disconnect power then remove the wires from the compressor terminals.
2. The resistance values between C and S and between C and R, when added together, should equal the resistance value between S and R.
3. If the overload is open, there will be a resistance reading between S and R, and open readings between C and S and between C and R. Allow the compressor to cool, then check the readings again.

### THREE PHASE COMPRESSORS

1. Disconnect power and remove the wires from the compressor terminals.
2. The resistance values between L1 and L2, between L2 and L3, and between L3 and L1 should all be equal.
3. If the overload is open, there will be open readings between L1 and L2, between L2 and L3, and between L3 and L1. Allow the compressor to cool, then check the readings again.

## **Check Motor Windings to Ground**

Check continuity between all three terminals and the compressor shell or copper refrigeration line. Scrape metal surface to get good contact. If continuity is present, the compressor windings are grounded and the compressor should be replaced.

## **Compressor Drawing Locked Rotor**

To determine if the compressor is seized, check the amp draw while the compressor is trying to start.

The two likely causes of this are a defective starting component and a mechanically seized compressor.

To determine which you have:

1. Install high and low side gauges.
2. Try to start the compressor.
3. Watch the pressures closely.
  - A. If the pressures do not move, the compressor is seized. Replace the compressor.
  - B. If the pressures move, the compressor is turning slowly and is not seized. Check the capacitors and relay.

## **COMPRESSOR DRAWING HIGH AMPS**

The continuous amperage draw on start-up should not be near the maximum fuse size indicated on the serial tag.

## **Diagnosing Capacitors**

- If the compressor attempts to start, or hums and trips the overload protector, check the starting components before replacing the compressor.
- Visual evidence of capacitor failure can include a bulged terminal end or a ruptured membrane. Do not assume a capacitor is good if no visual evidence is present.
- A good test is to install a known good substitute capacitor.
- Use a capacitor tester when checking a suspect capacitor. Clip the bleed resistor off the capacitor terminals before testing.

## DIAGNOSING START COMPONENTS

If the compressor attempts to start, or hums and trips the overload protector, check the start components before replacing the compressor.

### Capacitor

Visual evidence of capacitor failure can include a bulged terminal end or a ruptured membrane. Do not assume a capacitor is good if no visual evidence is present. A good test is to install a known good substitute capacitor. Use a capacitor tester when checking a suspect capacitor. Clip the bleed resistor off the capacitor terminals before testing.

### Relay

The relay has a set of contacts that connect and disconnect the start capacitor from the compressor start winding. The contacts on the relay are normally closed (start capacitor in series with the start winding). The relay senses the voltage generated by the start winding and opens the contacts as the compressor motor starts. The contacts remain open until the compressor is de-energized.



### Warning

Disconnect electrical power to the ice machine before proceeding.

## Relay Operation Check

1. Disconnect wires from relay terminals.
2. Verify the contacts are closed.  
Measure the resistance between terminals 1 and 2. No continuity indicates open contacts. Replace the relay.
3. Check the relay coil.  
Measure the resistance between terminals 2 and 5. No resistance indicates an open coil. Replace the relay.
4. Move toggle switch to the ICE position.
5. The compressor start winding should energize for less than 1 second. Continued high amperage draw could indicate:
  - Low incoming power supply.  
(Check voltage at compressor start-up when load is greatest.)
  - Defective relay.
  - Defective capacitor.
  - Defective compressor.
6. Verify voltage and replace all start components.
7. If all of the previous tests are satisfactory and the compressor will not operate or continue to operate, replace the compressor.

## Self Contained Air Cooled Models

### FAN CYCLE CONTROL

#### (Self-Contained Air-Cooled Models Only)

#### FUNCTION

Cycles the fan motor on and off to maintain proper operating discharge pressure.

The fan cycle control closes on an increase, and opens on a decrease in discharge pressure.

<b>Specifications</b>		
<b>Model</b>	<b>Cut-In (Close)</b>	<b>Cut-Out (Open)</b>
QF800/QC700	250 ±5 (1723 kPa ±.34) (17.23 bar ±.34)	200 ±5 (1517 kPa ±.34) (15.17 bar ±.34)

#### CHECK PROCEDURE

1. Verify fan motor windings are not open or grounded, and fan spins freely.
2. Connect manifold gauges to ice machine.
3. Hook voltmeter in parallel across the fan cycle control, leaving wires attached.
4. Refer to chart below.

<b>FCC Setpoint:</b>	<b>Reading Should Be:</b>	<b>Fan Should Be:</b>
Above Cut-In	0 Volts	Running
Below Cut-Out	Line Voltage	Off

## **Self Contained Water-cooled Models**

### **WATER REGULATING VALVE**

#### **(Water-Cooled Models Only)**

##### GENERAL

The water regulating valve maintains the freeze cycle discharge pressure.

##### CHECK PROCEDURE

1. Determine if the head pressure is high or low (refer to “Operational Pressure Charts”).
2. Verify the condenser water meets specifications.
3. Adjust valve to increase or decrease discharge pressure.
4. If the valve will not maintain the correct discharge pressure clean or replace as needed.



## **Headmaster Control Valve**

### **SF900A/SN950A/SF1200A/SN1250A/SF2000A/ SN2050A Remote Condensers, Remote Condensing Units &**

#### **FUNCTION**

The headmaster control valve maintains the correct discharge pressure and liquid line temperature.

These machines use the headmaster at low ambient conditions to maintain the head pressure and evaporator suction pressure in the correct range.

Diagnostics are the same for all applications.

Manitowoc Ice Machine systems require headmaster control valves with special settings. Replace defective headmaster control valves only with “original” Manitowoc replacement parts.

#### **FREEZE CYCLE OPERATION**

##### **Air-Cooled Ice Machines**

During low ambient conditions, it is normal for the head pressure control valve to hunt (head pressure may fluctuate up and down) and generally settles out within the first 6 minutes of the freeze cycle.

At ambient temperatures of approximately 70°F (21°C) or above, refrigerant flows through the condenser to the receiver inlet. At temperatures below this (or at higher temperatures if it is raining), the head pressure controls nitrogen dome charge starts to modulate (closes the condenser port and opens the bypass port from the compressor discharge line).

In this modulating mode, the valve maintains minimum head pressure by building up liquid in the condenser and bypassing discharge gas directly to the liquid line.

##### **Freeze Cycle**

1. Determine the air temperature entering the condenser.
2. Determine if the head pressure is high or low in relationship to the outside temperature. (Refer to the proper “Operational Pressure Chart”) If the air temperature is below 70°F (21.1°C), the head pressure control will modulate to maintain the correct liquid line temperature and head pressure.

3. Determine the temperature of the liquid line entering the receiver by feeling it. This line is normally warm; “body temperature.”
4. Using the information gathered, refer to the chart below.

NOTE: A headmaster that will not bypass, will function properly with condenser air temperatures of approximately 70°F (21.1°C) or above. When the temperature drops below 70°F (21.1°C), the headmaster fails to bypass and the ice machine malfunctions. Rinsing the condenser with cool water during the freeze cycle will simulate lower ambient conditions.

### Freeze Cycle Headmaster Control Valve Failure List

Symptom	Probable Cause	Corrective Measure
Valve not maintaining pressures	Non-approved valve	Install a Manitowoc Headmaster control valve with proper setting
Discharge pressure extremely high; Liquid line entering receiver feels hot	Valve stuck in bypass	Replace valve
Discharge pressure low; Liquid line entering receiver feels extremely cold	Valve not bypassing	Replace valve

## Refrigerant Recovery/Evacuation

### **NORMAL SELF-CONTAINED PROCEDURES**

Do not purge refrigerant to the atmosphere. Capture refrigerant using recovery equipment. Follow the manufacturer's recommendations.

#### **Important**

Manitowoc Ice, Inc. assumes no responsibility for the use of contaminated refrigerant. Damage resulting from the use of contaminated refrigerant is the sole responsibility of the servicing company.

#### **Important**

Replace the liquid line drier before evacuating and recharging. Use only a Manitowoc (OEM) liquid line filter-drier to prevent voiding the warranty.

### **CONNECTIONS**

Manifold gauge sets must utilize low loss fittings to comply with U.S. Government rules and regulations.

Make these connections:

- Suction side of the compressor through the suction service valve.
- Discharge side of the compressor through the discharge service valve.

## Recovery/Evacuation Procedures

1. Place the toggle switch in the OFF position.
2. Install manifold gauges, scale, and recovery unit or two-stage vacuum pump.

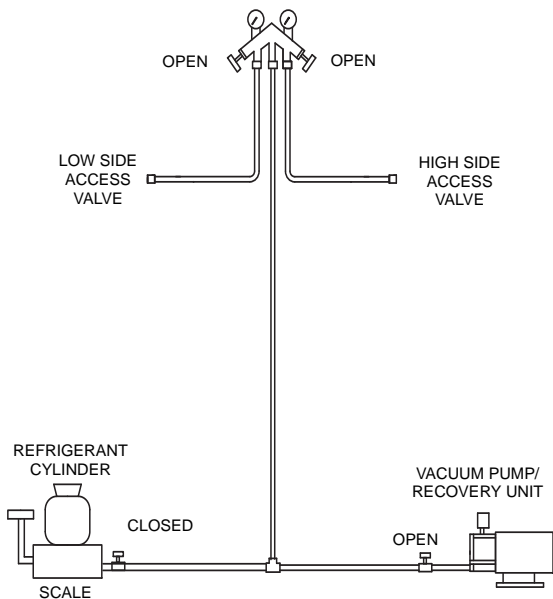

**RECOVERY/EVACUATION CONNECTIONS**

3. Perform recovery or evacuation:
  - A. Recovery: Operate the recovery unit as directed by the manufacturer's instructions.
  - B. Evacuation prior to recharging: Pull the system down to 250 microns. Then allow the pump to run for an additional half hour. Turn off the pump and perform a standing vacuum leak check.

**NOTE:** Check for leaks using a halide or electronic leak detector after charging the ice machine.

4. Follow the Charging Procedures on the next page.

## Charging Procedures

### Important

The charge is critical on all Manitowoc ice machines. Use a scale to ensure the proper charge is installed.

1. Be sure the toggle switch is in the OFF position.

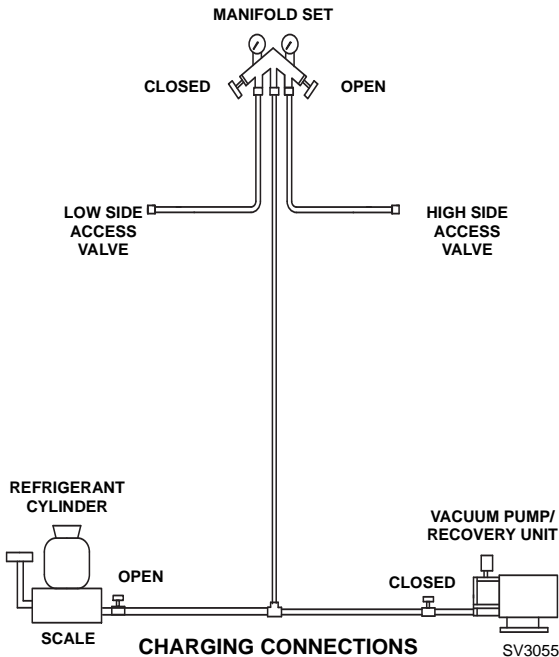

2. Close the vacuum pump valve and the low side manifold gauge valve.
3. Open the high side manifold gauge valve.
4. Open the refrigerant cylinder and add the proper refrigerant charge (shown on nameplate) through the discharge access valve.
5. Let the system "settle" for 2 to 3 minutes.
6. Place the toggle switch in the ICE position.

7. Close the high side on the manifold gauge set.  
Add any remaining vapor charge through the suction access valve (if necessary).

NOTE: Manifold gauges must be removed properly to ensure that no refrigerant contamination or loss occurs.

8. Make sure that all of the vapor in the charging hoses is drawn into the ice machine before disconnecting the charging hoses.
  - A. Run the ice machine in the Freeze cycle.
  - B. Remove the quick disconnect fitting from the high side access valve at the ice machine.
  - C. Open the low side service valve at the ice machine.
  - D. Open the high and low side valves on the manifold gauge set. Any refrigerant in the lines will be pulled into the low side of the system.
  - E. Allow the pressures to equalize while the ice machine is in the Freeze cycle.
  - F. Remove the quick disconnect fitting from the low side access valve at the ice machine and install both access valve caps.

## REMOTE AIR-COOLED MODELS

Do not purge refrigerant to the atmosphere. Capture refrigerant using recovery equipment. Follow the manufacturer's recommendations.

### Important

Manitowoc Ice, Inc. assumes no responsibility for the use of contaminated refrigerant. Damage resulting from the use of contaminated refrigerant is the sole responsibility of the servicing company.

### Important

Replace the liquid line drier before evacuating and recharging. Use only a Manitowoc (OEM) liquid line filter-drier to prevent voiding the warranty.

## Connections

Manifold gauge sets must utilize low loss fittings to comply with U.S. Government rules and regulations. Make these connections:

- Suction side of the compressor through the suction shut-off valve.
- Discharge side of the compressor through the liquid line shut-off valve.
- Receiver service valve, which evacuates the area between the check valve in the liquid line and the liquid line solenoid valve



### Warning

Recovery/Evacuation requires connections at three points for complete system recovery/evacuation. A check valve is located in the ice machine head section between the liquid line shut-off valve and the receiver. The check valve prevents refrigerant migration from the receiver to the condensing unit in the off cycle. Connections must be made at three points (receiver service valve, suction line and liquid line) to allow recovery and evacuation of the entire system.

## Recovery/Evacuation

1. Place the toggle switch in the OFF position and disconnect all power to the ice machine and condensing unit.
2. Install the manifold gauges, charging scale and recovery unit or two-stage vacuum pump.
3. Open the receiver service valve halfway.
4. Open high and low side on the manifold gauge set.
5. Perform recovery or evacuation:
  - A. Recovery: Operate the recovery unit as directed by the manufacturer's instructions.
  - B. Evacuation prior to recharging: Evacuate to 500 microns. Then allow the pump to run for an additional hour. Turn off the pump and perform a standing vacuum leak check.
6. Refer to Charging Procedures.

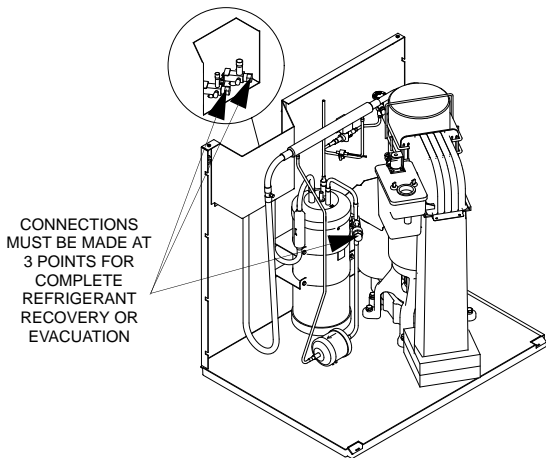

### **Warning**

The receiver service valve (located in the ice machine head section) must be accessed during refrigerant recovery to allow complete removal of the refrigerant charge.



## Remote Model Charging Procedures

1. Be sure the toggle switch is in the OFF position.
2. Close the vacuum pump valve and the low side manifold gauge valve.
3. Open the refrigerant cylinder and add the proper refrigerant charge (shown on nameplate) into the system high side (receiver service valve and discharge line quick-connect fitting).
4. If the high side does not take the entire charge, close the high side on the manifold gauge set. Start the ice machine and add the remaining charge through the suction filter low side service port. Compressor damage can result.
5. Ensure all vapor in charging hoses is drawn into the low side of the system, then disconnect the manifold gauges.
6. Run the ice machine in freeze cycle.
7. Close the receiver service valve in the ice machine head section.
8. Disconnect the manifold gauge set from the liquid line shut-off valve.
9. Open the high and low side valves on the manifold gauge set. Any refrigerant in the lines will be pulled into the low side of the system.
10. Allow the pressures to equalize while the ice machine is in the freeze cycle.
11. Disconnect the manifold gauge set from the suction line shut-off valve.
12. Remove the hoses from the ice machine and install the caps.

**NOTE:** Check for refrigerant leaks after all valve caps have been installed.

# System Contamination Clean-Up

## General

This section describes the basic requirements for restoring contaminated systems to reliable service.

### Important

Manitowoc Ice, Inc. assumes no responsibility for the use of contaminated refrigerant. Damage resulting from the use of contaminated refrigerant is the sole responsibility of the servicing company.

## DETERMINING SEVERITY OF CONTAMINATION

System contamination is generally caused by either moisture or residue from compressor burnout entering the refrigeration system.

Inspection of the refrigerant usually provides the first indication of system contamination. Obvious moisture or an acrid odor in the refrigerant indicates contamination.

If either condition is found, or if contamination is suspected, use a Total Test Kit from Totaline or a similar diagnostic tool. These devices sample refrigerant, eliminating the need to take an oil sample. Follow the manufacturer's directions.

If a refrigerant test kit indicates harmful levels of contamination, or if a test kit is not available, inspect the compressor oil.

1. Remove the refrigerant charge from the ice machine.
2. Remove the compressor from the system.
3. Check the odor and appearance of the oil.
4. Inspect open suction and discharge lines at the compressor for burnout deposits.
5. If no signs of contamination are present, perform an acid oil test.

Check the chart on the next page to determine the type of cleanup required.

<b>Contamination Cleanup Chart</b>	
<b>Symptoms/Findings</b>	<b>Required Cleanup Procedure</b>
No symptoms or suspicion of contamination	Normal evacuation/recharging procedure
Moisture/Air Contamination symptoms Refrigeration system open to atmosphere for longer than 15 minutes Refrigeration test kit and/or acid oil test shows contamination Leak in water cooled condenser No burnout deposits in open compressor lines	Mild contamination cleanup procedure
Mild Compressor Burnout symptoms Oil appears clean but smells acid Refrigeration test kit or acid oil test shows harmful acid content No burnout deposits in open compressor lines	Mild contamination cleanup procedure
Severe Compressor Burnout symptoms Oil is discolored, acidic, and smells acid Burnout deposits found in the compressor, lines, and other components	Severe contamination cleanup procedure

## CLEANUP PROCEDURE

### Mild System Contamination

1. Replace any failed components.
2. If the compressor is good, change the oil.
3. Replace the liquid line drier.

**NOTE:** If the contamination is from moisture, use heat lamps during evacuation. Position them at the compressor, condenser and evaporator prior to evacuation. Do not position heat lamps too close to plastic components, or they may melt or warp.

### Important

Dry nitrogen is recommended for this procedure. This will prevent CFC release.

4. Follow the normal evacuation procedure, except replace the evacuation step with the following:
  - A. Pull vacuum to 1000 microns. Break the vacuum with dry nitrogen and sweep the system. Pressurize to a minimum of 5 psig (35 kPa,.35 bar).
  - B. Pull vacuum to 500 microns. Break the vacuum with dry nitrogen and sweep the system. Pressurize to a minimum of 5 psig (35 kPa,.35 bar).
  - C. Change the vacuum pump oil.
  - D. Pull vacuum to 500 microns. Run the vacuum pump for 1/2 hour on self-contained models, 1 hour on remotes.

**NOTE:** You may perform a standing vacuum test to make a preliminary leak check. You should use an electronic leak detector after system charging to be sure there are no leaks.

5. Charge the system with the proper refrigerant to the nameplate charge.
6. Operate the ice machine.

## Severe System Contamination

1. Remove the refrigerant charge.
2. Remove the compressor.
3. Disassemble the harvest solenoid valve. If burnout deposits are found inside the valve, install a new harvest valve, replace the manifold strainer, TXV and harvest pressure regulating valve.
4. Wipe away any burnout deposits from suction and discharge lines at compressor.
5. Sweep through the open system with dry nitrogen.

### **Important**

Refrigerant sweeps are not recommended, as they release CFCs into the atmosphere.

6. Install a new compressor and new start components.
7. Install a suction line filter-drier with acid and moisture removal capability. Place the filter drier as close to the compressor as possible.
8. Install an access valve at the inlet of the suction line drier.
9. Install a new liquid line drier.

## **Important**

Dry nitrogen is recommended for this procedure. This will prevent CFC release.

10. Follow the normal evacuation procedure, except replace the evacuation step with the following:
  - A. Pull vacuum to 1000 microns. Break the vacuum with dry nitrogen and sweep the system. Pressurize to a minimum of 5 psig (35 kPa,.35 bar).
  - B. Change the vacuum pump oil.
  - C. Pull vacuum to 500 microns. Break the vacuum with dry nitrogen and sweep the system. Pressurize to a minimum of 5 psig (35 kPa,.35 bar).
  - D. Change the vacuum pump oil.
  - E. Pull vacuum to 500 microns. Run the vacuum pump for 1/2 hour on self-contained models, 1 hour on remotes.

NOTE: You may perform a standing vacuum test to make a preliminary leak check. You should use an electronic leak detector after system charging to be sure there are no leaks.

11. Charge the system with the proper refrigerant to the nameplate charge.
12. Operate the ice machine for one hour. Then, check the pressure drop across the suction line filter-drier.
  - A. If the pressure drop is less than 1 psig (7 kPa,.7 bar), the filter-drier should be adequate for complete cleanup.
  - B. If the pressure drop exceeds 1 psig (7 kPa,.7 bar), change the suction line filter-drier and the liquid line drier. Repeat until the pressure drop is acceptable.
13. Operate the ice machine for 48-72 hours. Then remove the suction line drier and change the liquid line drier.
14. Follow normal evacuation procedures.

## REPLACING PRESSURE CONTROLS WITHOUT REMOVING REFRIGERANT CHARGE

This procedure reduces repair time and cost. Use it when any of the following components require replacement, and the refrigeration system is operational and leak-free.

- Fan cycle control (air cooled only)
- Water regulating valve (water cooled only)
- High pressure cut-out control
- High side service valve
- Low side service valve

### Important

This is a required in-warranty repair procedure.

1. Disconnect power to the ice machine.
2. Follow all manufacturer's instructions supplied with the pinch-off tool. Position the pinch-off tool around the tubing as far from the pressure control as feasible. (See the figure on next page.) Clamp down on the tubing until the pinch-off is complete.



### Warning

Do not unsolder a defective component. Cut it out of the system. Do not remove the pinch-off tool until the new component is securely in place.

3. Cut the tubing of the defective component with a small tubing cutter.
4. Solder the replacement component in place. Allow the solder joint to cool.
5. Remove the pinch-off tool.
6. Re-round the tubing. Position the flattened tubing in the proper hole in the pinch-off tool. Tighten the wing nuts until the block is tight and the tubing is rounded.

NOTE: The pressure controls will operate normally once the tubing is re-rounded. Tubing may not re-round 100%.

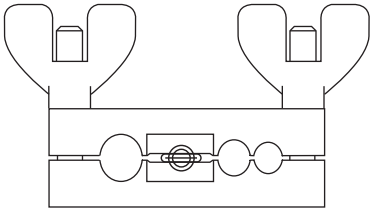

**FIG. A – PINCHING OFF TUBING**

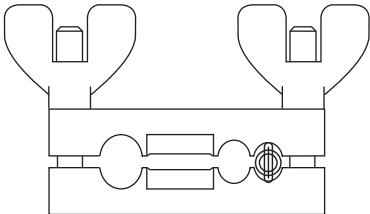

**FIG. B – RE-ROUNDING TUBING**

**SV1406**

**USING PINCH-OFF TOOL**



**This Page Intentionally Left Blank**

## **Gear Box Removal**

### **QF0400**

The evaporator and motor / gearbox are separate assemblies. Warranty procedures require replacement of the entire evaporator or motor /gearbox assembly. Field rebuilding during the warranty period is not allowed.

1. Disconnect power to the ice machine.
2. Remove water level probes, water reservoir cover, float valve, water reservoir, ice chute, and drain tubing (refer to Component Removal).
3. Remove bolts securing foundation coupling to gear motor assembly.
4. Lift evaporator and rest on top of foundation coupling.
5. Disconnect line voltage wiring at motor Molex connector.
6. Remove two screws holding motor speed sensor and remove sensor.
7. Remove coupling, spline hub and keyway from gear motor.
8. Support motor / gearbox assembly and remove 4 bolts securing gear motor assembly to base.
9. Remove gear motor assembly from ice machine.

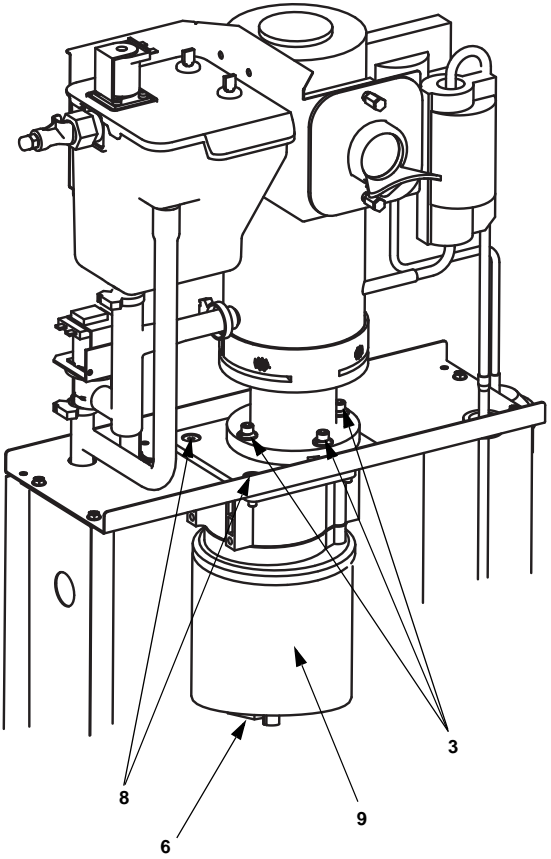

## **QC0700/QF0800**

### **GEAR BOX REMOVAL**

The evaporator and motor / gearbox are separate assemblies. Warranty procedures require replacement of the entire evaporator or motor /gearbox assembly. Field rebuilding during the warranty period is not allowed.

1. Disconnect power to the ice machine.
2. Remove water level probes, water reservoir cover, float valve, water reservoir, ice chute, and drain tubing (refer to Component Removal).
3. Remove bolts securing foundation coupling to gear motor assembly.
4. Lift evaporator and rest on top of foundation coupling.
5. Disconnect line voltage wiring at motor Molex connector.
6. Remove two screws holding motor speed sensor and remove sensor.
7. Remove bolts securing gear motor assembly mounting bracket to base.
8. Remove gear motor assembly from ice machine.
9. Remove coupling, spline hub, keyway, and mounting bracket from gear motor.

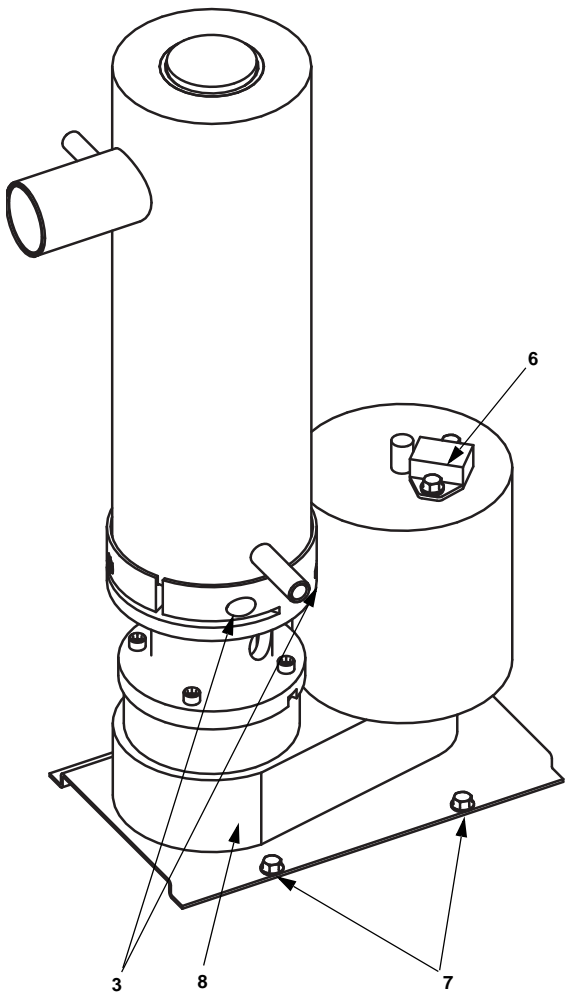

## **QF2200/QF2300**

### **GEAR BOX REMOVAL**

The evaporator and motor / gearbox are separate assemblies. Warranty procedures require replacement of the entire evaporator or motor /gearbox assembly. Field rebuilding during the warranty period is not allowed.

1. Disconnect power and water supply to the ice machine and drain all water from the reservoir and evaporator.
2. Remove reservoir retaining pin, water reservoir, ice chute, and drain tubing (refer to Component Removal).
3. Remove bolts securing foundation coupling to base.
4. Lift and support evaporator (evaporator weighs 80 lbs.).
5. Remove gear motor drip shield and disconnect line voltage wiring at motor Molex connector.
6. Remove two screws holding motor speed sensor and remove sensor.
7. Remove bolts securing gear motor assembly to base.
8. Remove gear motor assembly from ice machine.
9. Remove coupling (use a 8 mm hex wrench for coupling set screw), spline hub and keyway from gear motor.

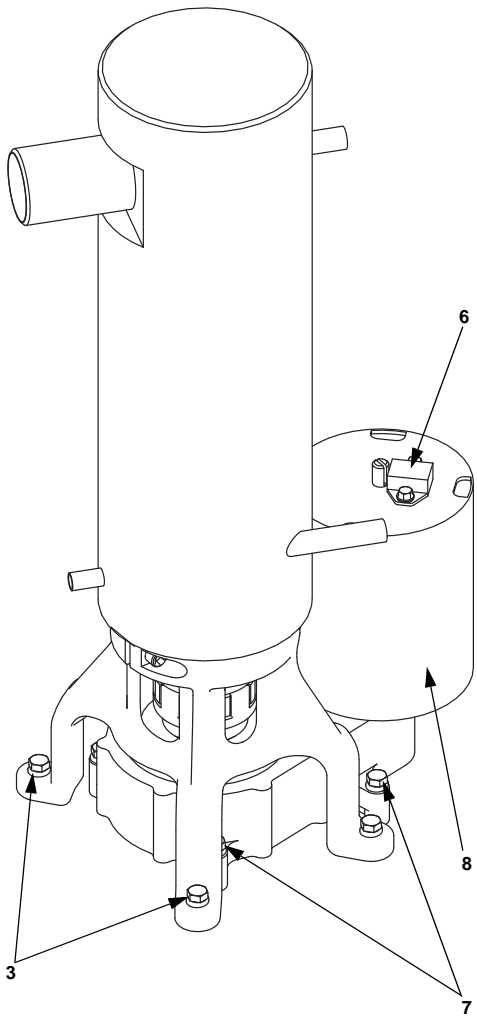

## Evaporator Re-Build Kits

An Evaporator Re-Build Kit is now available for out of warranty Flake and Chiplet Ice Machine evaporators. Defective in warranty evaporators must be replaced, the warranty does not allow re-building. There are kits for different sized evaporators as well evaporators that may need the auger changed.

- Evaporators can only be re-built with the kit.
- When an evaporator is disassembled all parts must be replaced.
- Parts are not available individually, only in kit form.

Included in the kit is a special tool that is required for disassembly/reassembly. The tool is used for bearing removal, proper seating of bearings and water seal.

### IDENTIFYING CORRECT KIT:

The augers inside of the evaporators are stamped with a letter, the letter indicates the date (A=2000, B=2001, C=2002, etc.). Remove the top cap on the auger and wipe off the grease to see the stamped letter. Use the chart below to determine the proper kit.

Re-Build Kit Part Numbers		
	Stamped A or B	
Model	Re-Build Kit	Re-Build Kit with Auger
<b>QF400 Stainless Steel Evap</b>	76-0166-3	76-0167-3
<b>QC700</b>	76-0168-3	76-0169-3
<b>QF800</b>	76-0168-3	76-0170-3
<b>QF2300</b>	76-0171-3	76-0172-3
	All Others	
Model	Re-Build Kit	Re-Build Kit with Auger
<b>QF400</b>	76-0166-3	76-0167-3
<b>QC700</b>	76-0166-3	76-0169-3
<b>QF800</b>	76-0166-3	76-0170-3
<b>QF2300</b>	76-0171-3	76-0172-3



## Contents of the Re-Build Kit:

Identified parts shown in drawing are included in the re-build kit.

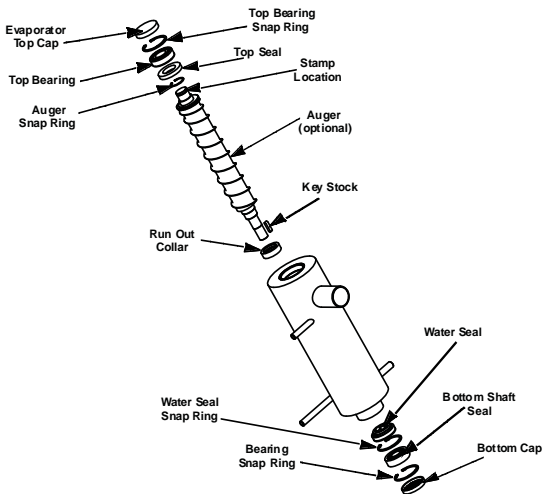

## Evaporator Disassembly

1. Remove spline hub and key stock. Sand shaft smooth where setscrew contacted shaft.

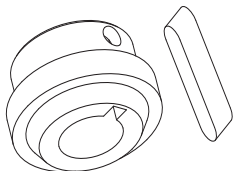

**SPLINE HUB AND KEY STOCK**

2. Remove evaporator top cap and grease from top of evaporator.
3. Remove top snap ring (big clip). (QF2300 Only - also remove spring shim.)
4. Drive auger shaft out through top of evaporator by placing wooden 2 x 4 on floor and tap auger shaft on 2 x 4.
5. Remove run-out collar (remove from bottom or run-out collar will be on the auger).
6. Remove bottom shaft seal.
7. Remove lower bearing snap ring. (QF2300 Only - also remove bearing shim.)
8. Drive out bottom bearing (QF2300 Only - also drive out second bearing shim) with bearing removal tool (top to bottom).
9. Remove water seal snap ring.
10. Remove water seal (top to bottom).
11. Remove snap ring from top of auger.
12. Remove top bearing with a bearing puller.
13. Remove top seal.

## **CLEANING EVAPORATOR AFTER DISASSEMBLY**

Inspect auger and check for damage to the following areas:

- Top bearing seat
- Top shaft seal area
- Bottom bearing seat
- Bottom seal area

Replace auger if bearings or seals are damaged

Clean the following with 460 grit emery cloths to remove contamination (new augers do not have to be cleaned):

- Auger Shaft
- Auger flights (both sides - top and bottom)

Do not clean the cutting head with sand paper. The cutting head self-cleans due to ice shear - emery cloth will dull the cutting edge. Sand the auger with emery cloth until all scale is removed.

### **Evaporator Barrel Cleaning:**

Assemble wheel stack on mandrel. Drill and shaft extension are required. Use speeds less than 200 RPM, slower = better. Keep moving up and down; do not stop in one spot.

### **Scotch-Brite Disc for Cleaning:**

Disc is larger than inside diameter of barrel for even contact.

2" Disc used on models QF400, QC700, and QF800.

4" Disc used on QF2300.

Clean thoroughly with multiple passes of disc and clean cloths. Thoroughly clean water inlet and ice outlet to complete the cleaning of the barrel.

## EVAPORATOR REASSEMBLY

NOTE: Upper bearing has dust seal. Bottom bearing does not have dust seal. Bearing seating tool and grease are included with kit.

1. Grease top shaft seal and install on auger.
2. Imprinted text on bearing must face up. Install top bearing, press on both inner/outer bearing race with special tool to seat.
3. Install run-on sleeve onto bottom of auger (taper must face seal).
4. Grease top and bottom bearing race.
5. Install auger into barrel from top down.
6. Install inner and outer snap rings at top bearing.
7. Seat upper bearing, use dead blow hammer to drive auger up and seat upper bearing on snap rings.
8. Install water seal use special tool to apply even pressure.
9. Install water seal snap ring use special tool to compress seal and seat snap ring.
10. Bottom bearing assembly (QF2300 Only - one bearing shim must be installed before bearing.) Roller thrust bearing is directional. Imprinted text on bearing race must face down, towards bottom of evaporator. The wider of the two races must face up, towards the evaporator.
11. Hand-pack bearing in grease and drive in place with special tool.
12. Install snap ring in bottom. (QF2300 Only - before installing snap ring, install bearing backup spring.)
13. Pack top cover with grease and install.
14. Install bottom seal. Work any air out from under the seal being careful not to cut the seal or score the shaft.
15. Hand-turn auger to check operation. You can see the first shoulder of the auger, when it is correctly installed.
16. Install key stock.
17. Install splined hub. (Must be flush with shaft.)

18. Evacuate and recharge.
19. Torque foundation bolts to 195-205 inch lbs.
20. Reassembly components removed in Step 2 of Remove Evaporator.
21. Reconnect power and water supply.
22. Test run ice machine.

## EVAPORATOR REMOVAL

### QF0400

The evaporator and motor / gearbox are separate assemblies. Warranty procedures require replacement of the entire evaporator or motor /gearbox assembly. Field rebuilding during the warranty period is not allowed.

1. Disconnect power to the ice machine.
2. Remove water level probes, water reservoir cover, float valve, water reservoir, ice chute, and drain tubing (refer to Component Removal).
3. Recover refrigerant and disconnect refrigeration tubing from evaporator.
4. Remove foundation-coupling bolts.
5. Lift evaporator out of foundation coupling and remove from ice machine.
6. Remove spline hub and keyway from evaporator.
7. After reinstallation of evaporator, torque foundation bolts to 195-250 inch lbs.

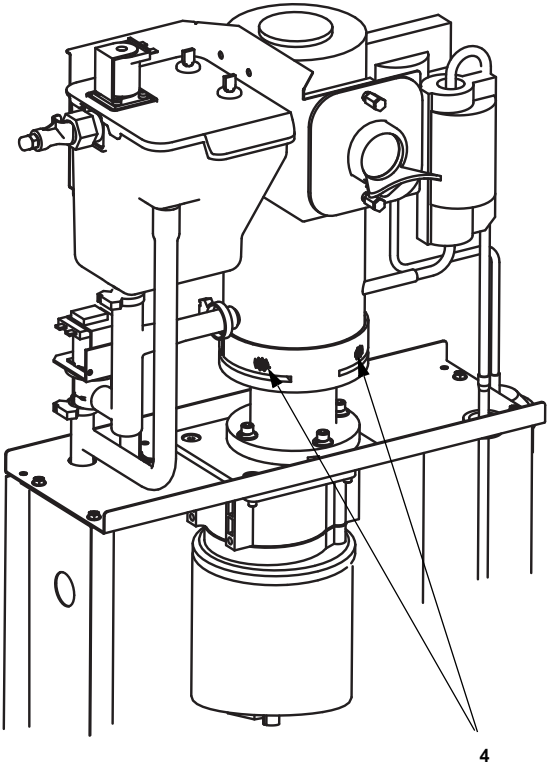

## **QC0700/QF0800**

### **EVAPORATOR REMOVAL**

The evaporator and motor / gearbox are separate assemblies. Warranty procedures require replacement of the entire evaporator or motor /gearbox assembly. Field rebuilding during the warranty period is not allowed.

1. Disconnect power to the ice machine.
2. Remove water level probes, water reservoir cover, float valve, water reservoir, ice chute, and drain tubing (refer to Component Removal).
3. Recover refrigerant and disconnect refrigeration tubing from evaporator.
4. Remove foundation-coupling bolts.
5. Lift evaporator out of foundation coupling and remove from ice machine.
6. Remove spline hub and keyway from evaporator.
7. After reinstallation of evaporator, torque foundation bolts to 195-250 inch lbs.



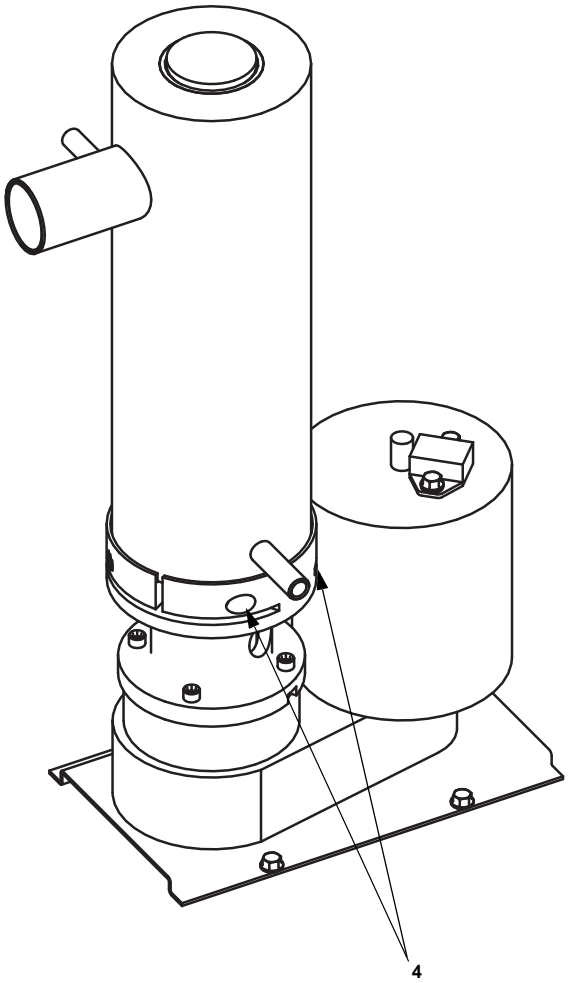

## **QF2200/QF2300**

### **EVAPORATOR REMOVAL**

The evaporator and motor / gearbox are separate assemblies. Warranty procedures require replacement of the entire evaporator or motor /gearbox assembly. Field rebuilding during the warranty period is not allowed.

1. Disconnect power and water supply to the ice machine and drain all water from the reservoir and evaporator.
2. Remove reservoir retaining pin, water reservoir, ice chute, and drain tubing (refer to Component Removal).
3. Recover refrigerant and disconnect refrigeration tubing from evaporator.
4. Remove foundation-coupling bolts.
5. Lift evaporator out of foundation coupling and remove from ice machine.
6. Remove spline hub and keyway from evaporator (8 mm hex wrench for coupling set screw).
7. After reinstallation of evaporator, torque foundation bolts to 195-250 inch lbs.

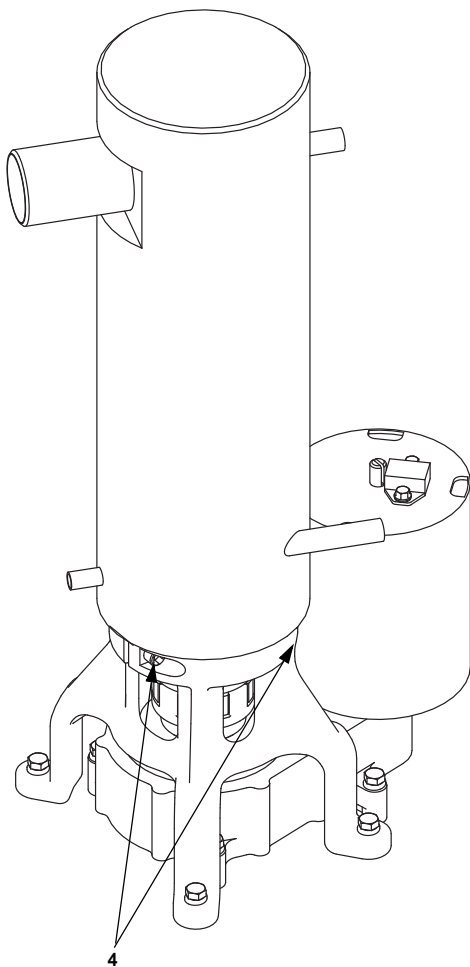



# Component Specifications

## MAIN FUSE

The main fuse is 250 Volt, 10 amp.

## ICE/OFF/CLEAN TOGGLE SWITCH

Single-pole, double-throw switch. The switch is connected into a varying low D.C. voltage circuit.

## FAN CYCLE CONTROL

(Self-Contained Air-Cooled Models Only)

Model	Cut-In (Close)	Cut-Out (Open)
QF800/QC700	250 $\pm$ 5 (1723 kPa $\pm$ .34) (17.23 bar $\pm$ .34)	200 $\pm$ 5 (1517 kPa $\pm$ .34) (15.17 bar $\pm$ .34)

## HIGH PRESSURE CUTOUT (HPCO) CONTROL

Cut-Out	Cut-In
450 psig $\pm$ 10 (3103 kPa $\pm$ 69) 31 bar $\pm$ .69	Automatic Reset
(Must be below 300 psig (2068 kPa 20.68 bar) to reset.)	

## TORQUE VALUES

Location	Inch Pounds	Set Screws
M24 Coupling	5-20	#10-24
Evap to Foundation	60 +/- 5	#1/4-20
Use Loctite 242		

## GEARMOTOR RPMS

Model	115V	230V
SN012 SN020	25.2	21.1
QF0400	8.3	8.9
QF0800 QC0700	15	
QF2200 QF2300	11.6	
SF0400 SN0450 SF0600 SN0650 SF0900 SN0950 SF0900C SN0950C SF1200 SN1250 SF1200 SN1250	21	

## FILTER-DRIERS

The filter-driers used on Manitowoc ice machines are manufactured to Manitowoc specifications.

The difference between a Manitowoc drier and an off-the-shelf drier is in filtration. A Manitowoc drier has dirt-retaining filtration, with fiberglass filters on both the inlet and outlet ends. This is very important because ice machines have a back-flushing action that takes place during every Harvest cycle.

A Manitowoc filter-drier has high moisture and acid removal capability.

The size of the filter-drier is important. The refrigerant charge is critical. Using an improperly sized filter-drier will cause the ice machine to be improperly charged with refrigerant.

Listed below is the recommended OEM field replacement drier:

Model	Drier Size	End Connection Size
SN012 SN020 QF0400 SF0400 SN0450 SF0600 SN0650 QF0800 QC0700 SF0900 SN0950	DML-032S	1/4"
SF0900C SN0950C	DML-052S	1/4"
SF1200 SN1250 QF2200 QF2300	DML-053S	3/8"

### Important

Driers are covered as a warranty part. The drier must be replaced any time the system is opened for repairs.

## SUCTION LINE FILTER

Remote condensing units have a suction line filter to trap particles introduced during field installation. The suction filter does not have acid or moisture removal capabilities.

Model	Drier Size	End Connection Size	Part Number
RFC0985 RFC1285	ASF35S5	5/8 in.	82-5053-9
RFC2085R FC2385	ASF45S6	3/4 in.	82-5026-3

## SUCTION CLEANUP FILTER-DRIER

Contaminated systems must have a suction line filter-drier installed to remove contamination. (See "System Contamination Cleanup.") An access valve must be installed on the inlet side of the suction filter to allow pressure drop readings to be obtained.

Suction Line Clean-Up Filter		
Model	Drier Size	End Connection Size
SN012/SN020 QF400 SF400/SN450 SF600/SN650 QF800/QC700 SF900/SN950 SF1200/SN1250	UK-165S	5/8 in.

## QF2200/RFC2085 and QF2300/RFC2385

Contact your local Manitowoc Distributor for a suction filter capable of cleaning the system. The clean-up filter drier must have a minimum nominal capacity of 3 hp. After clean-up is complete (See "System Contamination Cleanup"), remove clean-up filter drier and replace with new suction filter.

## Total System Refrigerant Charge

### Important

This information is for reference only. Refer to the ice machine serial number tag to verify the system charge. Serial plate information overrides information listed on this page.

Model	Refrigerant Charge
SN12A/SN20A	10 oz. / 284 g
QF400A	Refer to Serial Plate
SF400A	12 oz. / 340 g
SN450A	10 oz. / 284 g
SF400W/SN450W	14 oz. / 397 g
SF600A	14 oz. / 397 g
SN650A	17 oz. / 482 g
SF600W	12 oz. / 340 g
SN650W	16 oz. / 454 g
SF600N/SN650N	5.5 lbs / 2.5 kg
QF800A/QC700A	20 oz. / 567 g
QF800W/QC700W	16 oz. / 454 g
SF900A/SN950A	2.5 lbs. / 1.1 kg
SF900W/SN950W	15 oz. / 425 g
SF900C/SN950C	9.75 lbs. / 4.4 kg
SF1200A/SN1250A	4.125 lbs. / 2.1 kg
SF1200W/SN1250W	28 oz. / 794 g
SF1200C/SN1250C	9.75 lbs. / 4.4 kg
QF2200/QF2300 RFC2085 RFC2385	0' to 50' linesets 12.5 lbs. / 5.7 kg  50' to 100' linesets 14.0 lbs. / 6.4 kg

NOTE: All ice machines are charged using R-404A refrigerant.



## Charts

---

### **Cycle Times/24-Hour Ice Production/ Refrigerant Pressure Charts**

These charts are used as guidelines to verify correct ice machine operation.

Accurate collection of data is essential to obtain the correct diagnosis.

- Refer to “Refrigeration System Diagnostics” for the data that must be collected. This list includes: before beginning service, ice production check, installation/visual inspection, water system checklist, safeguards, discharge and suction pressure analysis.
- Ice production checks that are within 10% of the chart are considered normal. This is due to variances in water and air temperature. Actual temperatures will seldom match the chart exactly.
- Zero out manifold gauge set before obtaining pressure readings to avoid misdiagnosis.
- Discharge and suction pressure are highest at the beginning of the cycle. Allow system to stabilize, then verify the pressures are within the range indicated.
- All pressure readings must be obtained at the ice machine head section. Lineset length will affect pressures at the condensing unit.
- Water temperature will affect suction and discharge pressure - 50° water temperature will result in pressures on the lower end of the ranges specified. 90° water temperatures will result in pressures on the upper end of the ranges specified.

**SN012A/SN020A****SELF-CONTAINED AIR-COOLED**

Characteristics will vary depending on operating conditions.

<b>24-HOUR ICE PRODUCTION</b>				
<b>Air Temperature Entering Condenser °F/°C</b>		<b>Water Temperature °F/°C</b>		
		<b>50/10</b>	<b>70/21</b>	<b>90/32</b>
50	10	325	300	280
70	21	300	275	255
80	27	265	250	230
90	32	240	225	210
100	38	210	195	185

<b>OPERATING PRESSURES (PSIG)</b>			
<b>Air Temperature Entering Condenser °F/°C</b>		<b>Freeze Cycle</b>	
		<b>Discharge Pressure</b>	<b>Suction Pressure</b>
50	10	170-180	29-32
70	21	225-245	33-37
90	32	295-315	38-44
100	38	335-350	41-47
110	43	375-400	47-52

## QF0400A STAINLESS STEEL EVAPORATOR

*Serial Numbers Prior to 110638713*

### SELF-CONTAINED AIR-COOLED

Characteristics will vary depending on operating conditions.

24-HOUR ICE PRODUCTION				
Air Temperature Entering Condenser °F/°C		Water Temperature °F/°C		
		50/10	70/21	90/32
70	21	395	360	335
80	27	375	320	300
90	32	335	300	270
100	38	295	250	240
110	43	255	230	225

OPERATING PRESSURES (PSIG)			
Air Temperature Entering Condenser °F/°C		Freeze Cycle	
		Discharge Pressure	Suction Pressure
50	10	160-180	27-29
70	21	210-235	32-35
80	27	250-295	34-39
90	32	285-315	37-41
100	38	320-360	40-46
110	43	370-405	44-49

## QF0400A BRONZE EVAPORATOR

*Serial Numbers After 110638713*

### SELF-CONTAINED AIR-COOLED

Characteristics will vary depending on operating conditions.

24-HOUR ICE PRODUCTION				
Air Temperature Entering Condenser °F/°C		Water Temperature °F/°C		
		50/10	70/21	90/32
70	21	410	385	360
80	27	390	365	335
90	32	375	345	315
100	38	360	325	290
110	43	345	305	270

OPERATING PRESSURES (PSIG)			
Air Temperature Entering Condenser °F/°C		Freeze Cycle	
		Discharge Pressure	Suction Pressure
50	10	160-200	38-42
60	16	190-230	41-46
70	21	210-250	43-48
80	27	220-280	44-49
90	32	300-345	45-50
100	38	325-390	48-53
110	43	360-410	50-55

**SF0400A****SELF-CONTAINED AIR-COOLED**

Characteristics will vary depending on operating conditions.

<b>24-HOUR ICE PRODUCTION</b>				
<b>Air Temperature Entering Condenser °F/°C</b>		<b>Water Temperature °F/°C</b>		
		<b>50/10</b>	<b>70/21</b>	<b>90/32</b>
70	21	430	385	345
80	27	385	350	315
90	32	340	330	290
100	38	290	280	265
110	43	250	245	240

<b>OPERATING PRESSURES (PSIG)</b>			
<b>Air Temperature Entering Condenser °F/°C</b>		<b>Freeze Cycle</b>	
		<b>Discharge Pressure</b>	<b>Suction Pressure</b>
50	10	130 - 200	30 - 34
70	21	190 - 250	35 - 40
80	27	285 - 310	35 - 41
90	32	285 - 320	36 - 42
100	38	300 - 345	38 - 46
110	43	130 - 200	30 - 34

**SF0400W****SELF-CONTAINED WATER-COOLED**

Characteristics will vary depending on operating conditions.

<b>24-HOUR ICE PRODUCTION</b>				
<b>Air Temperature Around Ice Machine °F/°C</b>		<b>Water Temperature °F/°C</b>		
		<b>50/10</b>	<b>70/21</b>	<b>90/32</b>
70	21	420	380	340
80	27	415	375	335
90	32	410	370	330
100	38	405	365	325
110	43	400	360	320

<b>OPERATING PRESSURES (PSIG)</b>			
<b>Air Temperature Around Ice Machine °F/°C</b>		<b>Freeze Cycle</b>	
		<b>Discharge Pressure</b>	<b>Suction Pressure</b>
50	10	225 - 235	33 - 37
70	21	225 - 235	33 - 37
90	32	225 - 235	33 - 37
100	38	225 - 235	33 - 38
110	43	225 - 235	34 - 40

**Condenser Water Consumption**

<b>Air Temp. Around Ice Machine °F / °C</b>	<b>Water Temperature °F/°C</b>		
	<b>50/10</b>	<b>70/21</b>	<b>90/32</b>
90/32	220	330	1970

Gallons of water per 24 hours

**SN0450A****SELF-CONTAINED AIR-COOLED**

Characteristics will vary depending on operating conditions.

<b>24-HOUR ICE PRODUCTION</b>				
<b>Air Temperature Entering Condenser °F/°C</b>		<b>Water Temperature °F/°C</b>		
		<b>50/10</b>	<b>70/21</b>	<b>90/32</b>
70	21	480	435	390
80	27	440	400	360
90	32	400	360	335
100	38	360	330	305
110	43	320	300	280

<b>OPERATING PRESSURES (PSIG)</b>			
<b>Air Temperature Entering Condenser °F/°C</b>		<b>Freeze Cycle</b>	
		<b>Discharge Pressure</b>	<b>Suction Pressure</b>
50	10	130 - 200	30 - 34
70	21	190 - 250	35 - 40
80	27	250 - 295	35 - 41
90	32	285 - 310	35 - 41
100	38	285 - 320	36 - 42
110	43	300 - 345	38 - 46

**SN0450W****SELF-CONTAINED WATER-COOLED**

Characteristics will vary depending on operating conditions.

<b>24-HOUR ICE PRODUCTION</b>				
<b>Air Temperature Around Ice Machine °F/°C</b>		<b>Water Temperature °F/°C</b>		
		<b>50/10</b>	<b>70/21</b>	<b>90/32</b>
70	21	480	435	385
80	27	475	430	380
90	32	470	420	375
100	38	465	415	370
110	43	460	410	365

<b>OPERATING PRESSURES (PSIG)</b>			
<b>Air Temperature Around Ice Machine °F/°C</b>		<b>Freeze Cycle</b>	
		<b>Discharge Pressure</b>	<b>Suction Pressure</b>
50	10	225 - 235	33 - 37
70	21	225 - 235	33 - 37
90	32	225 - 235	33 - 37
100	38	225 - 235	33 - 38
110	43	225 - 235	34 - 40



**SF0600A****SELF-CONTAINED AIR-COOLED**

Characteristics will vary depending on operating conditions.

<b>24-HOUR ICE PRODUCTION</b>				
<b>Air Temperature Entering Condenser °F/°C</b>		<b>Water Temperature °F/°C</b>		
		<b>50/10</b>	<b>70/21</b>	<b>90/32</b>
70	21	670	610	550
80	27	610	555	505
90	32	550	505	460
100	38	490	450	415
110	43	670	610	550

<b>OPERATING PRESSURES (PSIG)</b>			
<b>Air Temperature Entering Condenser °F/°C</b>		<b>Freeze Cycle</b>	
		<b>Discharge Pressure</b>	<b>Suction Pressure</b>
50	10	120 - 140	26 - 28
70	21	220 - 270	32 - 35
80	27	240 - 275	35 - 38
90	32	255 - 290	37 - 39
100	38	300 - 340	38 - 44
110	43	330 - 360	43 - 48

**SF0600W****SELF-CONTAINED WATER-COOLED**

Characteristics will vary depending on operating conditions.

<b>24-HOUR ICE PRODUCTION</b>				
<b>Air Temperature Around Ice Machine °F/°C</b>		<b>Water Temperature °F/°C</b>		
		<b>50/10</b>	<b>70/21</b>	<b>90/32</b>
70	21	640	560	485
80	27	635	555	475
90	32	630	550	470
100	38	630	545	460
110	43	625	540	455

<b>OPERATING PRESSURES (PSIG)</b>			
<b>Air Temperature Around Ice Machine °F/°C</b>		<b>Freeze Cycle</b>	
		<b>Discharge Pressure</b>	<b>Suction Pressure</b>
50	10	225-235	33 - 36
70	21	225-235	33 - 36
80	27	225-240	33 - 37
90	32	225 - 250	34 - 37
100	38	225 - 255	34 - 38
110	43	225 - 260	34 - 38

**Condenser Water Consumption**

<b>Air Temp. Around Ice Machine °F / °C</b>	<b>Water Temperature °F/°C</b>		
	<b>50/10</b>	<b>70/21</b>	<b>90/32</b>
90/32	370	2850	5390

Gallons of water per 24 hours

**SF0600N****QUIETQUBE REMOTE AIR-COOLED**

Characteristics will vary depending on operating conditions.

<b>24-HOUR ICE PRODUCTION</b>				
<b>Air Temperature Entering Condenser °F/°C</b>		<b>Water Temperature °F/°C</b>		
		<b>50/10</b>	<b>70/21</b>	<b>90/32</b>
-20 to 70	-29 to 21	630	575	525
80	27	605	555	505
90	32	580	550	485
100	38	560	510	465
110	43	435	490	445

<b>OPERATING PRESSURES (PSIG)</b>			
<b>Air Temperature Entering Condenser °F/°C</b>		<b>Freeze Cycle</b>	
		<b>Discharge Pressure</b>	<b>Suction Pressure</b>
-20 to 50F	-29 to 10C	215 - 225	30 - 35
70	21	220 - 250	32 - 36
80	27	240 - 275	32 - 37
90	32	250 - 280	34 - 38
100	38	290 - 310	34 - 39
110	43	320 - 345	35 - 40
<b>JC0495 Condenser</b>			

**SN0650A****SELF-CONTAINED AIR-COOLED**

Characteristics will vary depending on operating conditions.

<b>24-HOUR ICE PRODUCTION</b>				
<b>Air Temperature Entering Condenser °F/°C</b>		<b>Water Temperature °F/°C</b>		
		<b>50/10</b>	<b>70/21</b>	<b>90/32</b>
70	21	730	670	615
80	27	680	620	570
90	32	620	565	520
100	38	570	520	475
110	43	515	470	430

<b>OPERATING PRESSURES (PSIG)</b>			
<b>Air Temperature Entering Condenser °F/°C</b>		<b>Freeze Cycle</b>	
		<b>Discharge Pressure</b>	<b>Suction Pressure</b>
50	10	120 - 140	26 - 28
70	21	220 - 270	32 - 35
80	27	240 - 275	35 - 38
90	32	255 - 290	37 - 39
100	38	300 - 340	38 - 44
110	43	330 - 360	43 - 48

**SN0650W****SELF-CONTAINED WATER-COOLED**

Characteristics will vary depending on operating conditions.

<b>24-HOUR ICE PRODUCTION</b>				
<b>Air Temperature Around Ice Machine °F/°C</b>		<b>Water Temperature °F/°C</b>		
		<b>50/10</b>	<b>70/21</b>	<b>90/32</b>
70	21	690	620	545
80	27	680	610	540
90	32	675	600	535
100	38	670	600	530
110	43	660	595	525

<b>OPERATING PRESSURES (PSIG)</b>			
<b>Air Temperature Around Ice Machine °F/°C</b>		<b>Freeze Cycle</b>	
		<b>Discharge Pressure</b>	<b>Suction Pressure</b>
50	10	220 - 250	33 - 36
70	21	220 - 250	33 - 36
80	27	220 - 250	33 - 37
90	32	225 - 250	34 - 37
100	38	225 - 255	34 - 38
110	43	225 - 260	34 - 38

**Condenser Water Consumption**

<b>Air Temp. Around Ice Machine °F / °C</b>	<b>Water Temperature °F/°C</b>		
	<b>50/10</b>	<b>70/21</b>	<b>90/32</b>
90/32	350	640	4325

Gallons of water per 24 hours

**SN0650N****REMOTE AIR-COOLED**

Characteristics will vary depending on operating conditions.

<b>24-HOUR ICE PRODUCTION</b>				
<b>Air Temperature Entering Condenser °F/°C</b>		<b>Water Temperature °F/°C</b>		
		<b>50/10</b>	<b>70/21</b>	<b>90/32</b>
-20 to 70	-29 to 21	690	600	535
80	27	640	580	515
90	32	615	585	500
100	38	600	540	480
110	43	575	520	460

<b>OPERATING PRESSURES (PSIG)</b>			
<b>Air Temperature Entering Condenser °F/°C</b>		<b>Freeze Cycle</b>	
		<b>Discharge Pressure</b>	<b>Suction Pressure</b>
-20 to 50F -29 to 10C		215 - 225	30 - 35
70	21	220 - 250	32 - 36
80	27	240 - 275	32 - 37
90	32	250 - 280	34 - 38
100	38	290 - 310	34 - 39
110	43	320 - 345	35 - 40
<b>JC0495 Condenser</b>			

**QC0700A****SELF-CONTAINED AIR-COOLED**

Characteristics will vary depending on operating conditions.

<b>24-HOUR ICE PRODUCTION</b>				
<b>Air Temperature Entering Condenser °F/°C</b>		<b>Water Temperature °F/°C</b>		
		<b>50/10</b>	<b>70/21</b>	<b>90/32</b>
70	21	710	710	710
80	27	710	710	710
90	32	710	710	700
100	38	710	710	670
110	43	710	670	630

<b>OPERATING PRESSURES (PSIG)</b>			
<b>Air Temperature Entering Condenser °F/°C</b>		<b>Freeze Cycle</b>	
		<b>Discharge Pressure</b>	<b>Suction Pressure</b>
70	21	200 – 235	18 – 22
80	27	250 – 320	20 – 26
90	32	270 – 340	23 – 29
100	38	320 – 350	26 – 34
110	43	360 – 400	29 – 41

**QC0700W****SELF-CONTAINED WATER-COOLED**

Characteristics will vary depending on operating conditions.

<b>24-HOUR ICE PRODUCTION</b>				
<b>Air Temperature Entering Condenser °F/°C</b>		<b>Water Temperature °F/°C</b>		
		<b>50/10</b>	<b>70/21</b>	<b>90/32</b>
70	21	710	695	655
80	27	710	695	655
90	32	700	685	630
100	38	690	675	615
110	43	670	660	600

<b>OPERATING PRESSURES (PSIG)</b>			
<b>Air Temperature Entering Condenser °F/°C</b>		<b>Freeze Cycle</b>	
		<b>Discharge Pressure</b>	<b>Suction Pressure</b>
70	21	225 – 235	18 – 22
80	27	225 – 235	20 – 26
90	32	225 – 240	23 – 29
100	38	230 – 245	26 – 34
110	43	230 – 250	29 – 41



**QF0800A****SELF-CONTAINED AIR-COOLED**

Characteristics will vary depending on operating conditions.

<b>24-HOUR ICE PRODUCTION</b>				
<b>Air Temperature Entering Condenser °F/°C</b>		<b>Water Temperature °F/°C</b>		
		<b>50/10</b>	<b>70/21</b>	<b>90/32</b>
70	21	760	750	740
80	27	760	750	710
90	32	760	740	680
100	38	760	700	660
110	43	730	670	610

<b>OPERATING PRESSURES (PSIG)</b>			
<b>Air Temperature Entering Condenser °F/°C</b>		<b>Freeze Cycle</b>	
		<b>Discharge Pressure</b>	<b>Suction Pressure</b>
70	21	220 – 235	18 – 22
80	27	250 – 320	20 – 26
90	32	270 – 340	23 – 29
100	38	320 – 350	26 – 34
110	43	360 – 400	29 – 41

**QF0800W****SELF-CONTAINED WATER-COOLED**

Characteristics will vary depending on operating conditions.

<b>24-HOUR ICE PRODUCTION</b>				
<b>Air Temperature Entering Condenser °F/°C</b>		<b>Water Temperature °F/°C</b>		
		<b>50/10</b>	<b>70/21</b>	<b>90/32</b>
<b>70</b>	<b>21</b>	780	760	725
<b>80</b>	<b>27</b>	780	760	725
<b>90</b>	<b>32</b>	770	750	700
<b>100</b>	<b>38</b>	760	740	670
<b>110</b>	<b>43</b>	740	730	660

<b>OPERATING PRESSURES (PSIG)</b>			
<b>Air Temperature Entering Condenser °F/°C</b>		<b>Freeze Cycle</b>	
		<b>Discharge Pressure</b>	<b>Suction Pressure</b>
<b>70</b>	<b>21</b>	225 – 235	18 – 22
<b>80</b>	<b>27</b>	225 – 235	20 – 26
<b>90</b>	<b>32</b>	225 – 240	23 – 29
<b>100</b>	<b>38</b>	230 – 245	26 – 34
<b>110</b>	<b>43</b>	230 – 250	29 – 41

**SF900A****SELF-CONTAINED AIR-COOLED**

Characteristics will vary depending on operating conditions.

<b>24-HOUR ICE PRODUCTION</b>			
<b>Air Temperature Entering Condenser °F/°C</b>		<b>Water Temperature °F/°C</b>	
		<b>50/10</b>	<b>70/21</b>
70	21	935	---
90	32	---	745

<b>OPERATING PRESSURES (PSIG)</b>			
<b>Air Temperature Entering Condenser °F/°C</b>		<b>Freeze Cycle</b>	
		<b>Discharge Pressure</b>	<b>Suction Pressure</b>
50	10	230-250	30-34
70	21	240-260	31-35
80	27	250-280	32-38
90	32	280-310	36-42
100	38	340-390	38-44
110	43	350-410	39-46

## SF900W

### SELF-CONTAINED WATER-COOLED

Characteristics will vary depending on operating conditions.

24-HOUR ICE PRODUCTION			
Air Temperature Around Ice Machine °F/°C		Water Temperature °F/°C	
		50/10	70/21
70	21	975	NA
90	32	NA	845

OPERATING PRESSURES (PSIG)			
Air Temperature Around Ice Machine °F/°C		Freeze Cycle	
		Discharge Pressure	Suction Pressure
50	10	220-225	30-32
70	21	220-225	30-33
80	26	220-225	30-34
90	32	220-225	31-34
100	38	225-235	32-35
110	43	230-240	33-36

### Condenser Water Consumption

Air Temp. Around Ice Machine 90°F/ 32°C	Water Temperature °F/°C <sup>1</sup>		
	50/10	70/21	90/32
Gal/100 lbs. of Ice	NA	116	NA

<sup>1</sup> Water regulating valve set to maintain 220 PSIG discharge pressure

**SF900C/RFC985**  
**REMOTE AIR-COOLED**

Characteristics will vary depending on operating conditions.

<b>24-HOUR ICE PRODUCTION</b>			
<b>Air Temperature Entering Condenser °F/°C</b>		<b>Water Temperature °F/°C</b>	
		<b>50/10</b>	<b>70/21</b>
70	21	955	NA
90	32	NA	810

<b>OPERATING PRESSURES (PSIG)</b>			
<b>Air Temperature Entering Condenser °F/°C</b>		<b>Freeze Cycle</b>	
		<b>Discharge Pressure</b>	<b>Suction Pressure</b>
-20 to 50F -29 to 10C		210-220	29-32
70	21	240-260	33-40
80	27	240-270	33-41
90	32	250-275	34-42
100	38	315-330	38-44
110	43	320-350	39-45

**SN950A****SELF-CONTAINED AIR-COOLED**

Characteristics will vary depending on operating conditions.

<b>24-HOUR ICE PRODUCTION</b>				
<b>Air Temperature Entering Condenser °F/°C</b>		<b>Water Temperature °F/°C</b>		
		<b>50/10</b>	<b>70/21</b>	<b>90/32</b>
70	21	970	870	775
80	27	885	800	715
90	32.	805	765	650
100	38	720	655	590
110	43	640	585	530

<b>OPERATING PRESSURES (PSIG)</b>			
<b>Air Temperature Entering Condenser °F/°C</b>		<b>Freeze Cycle</b>	
		<b>Discharge Pressure</b>	<b>Suction Pressure</b>
50	10	220-250	34-38
70	21	220-250	34-38
80	27	250-300	36-40
90	32	280-310	38-42
100	38	320-380	38-44
110	43	330-400	38-45

## SN950W

### SELF-CONTAINED WATER-COOLED

Characteristics will vary depending on operating conditions.

24-HOUR ICE PRODUCTION				
Air Temperature Around Ice Machine °F/°C		Water Temperature °F/°C		
		50/10	70/21	90/32
70	21	1040	905	770
80	27	1030	900	765
90	32	1025	900	760
100	38	1015	885	755
110	43	1005	875	750

OPERATING PRESSURES (PSIG)			
Air Temperature Around Ice Machine °F/°C		Freeze Cycle	
		Discharge Pressure	Suction Pressure
50	10	220-250	33-36
70	21	220-250	33-36
80	27	220-250	33-37
90	32	225-250	34-37
100	38	225-255	34-39
110	43	225-260	35-40

### Condenser Water Consumption

Air Temp. Around Ice Machine 90°F/ 32°C	Water Temperature °F/°C <sup>1</sup>		
	50/10	70/21	90/32
Gal/100 lbs. of Ice	NA	116	NA

1 Water regulating valve set to maintain 220 PSIG discharge pressure

**SN950C/RFC985****QUIETQUBE REMOTE AIR-COOLED**

Characteristics will vary depending on operating conditions.

<b>24-HOUR ICE PRODUCTION</b>				
<b>Air Temperature Entering Condenser °F/°C</b>		<b>Water Temperature °F/°C</b>		
		<b>50/10</b>	<b>70/21</b>	<b>90/32</b>
70	21	1015	920	825
80	27	970	880	795
90	32	925	880	765
100	38	875	805	735
110	43	830	770	710

<b>OPERATING PRESSURES (PSIG)</b>			
<b>Air Temperature Entering Condenser °F/°C</b>		<b>Freeze Cycle</b>	
		<b>Discharge Pressure</b>	<b>Suction Pressure</b>
-20 to 50F -29 to 10C		215-225	28-35
70	21	220-250	32-36
80	27	240-275	32-37
90	32	250-280	34-38
100	38	320-380	36-43
110	43	350-400	38-45



**SF1200A****SELF-CONTAINED AIR-COOLED**

Characteristics will vary depending on operating conditions.

<b>24-HOUR ICE PRODUCTION</b>			
<b>Air Temperature Entering Condenser °F/°C</b>		<b>Water Temperature °F/°C</b>	
		<b>50/10</b>	<b>70/21</b>
70	21	1220	NA
90	32	NA	1020

<b>OPERATING PRESSURES (PSIG)</b>			
<b>Air Temperature Entering Condenser °F/°C</b>		<b>Freeze Cycle</b>	
		<b>Discharge Pressure</b>	<b>Suction Pressure</b>
50	10	235-250	31-35
70	21	240-260	32-36
80	27	250-275	33-38
90	32	275-300	35-40
100	38	350-375	40-47
110	43	365-385	42-48

## SF1200W

### SELF-CONTAINED WATER-COOLED

Characteristics will vary depending on operating conditions.

24-HOUR ICE PRODUCTION			
Air Temperature Entering Condenser °F/°C		Water Temperature °F/°C	
		50/10	70/21
70	21	1270	NA
90	32	NA	1105

OPERATING PRESSURES (PSIG)			
Air Temperature Around Ice Machine °F/°C		Freeze Cycle	
		Discharge Pressure	Suction Pressure
50	10	225-230	30-32
70	21	225-230	30-33
80	27	225-230	31-33
90	32	225-230	31-33
100	38	230-235	31-34
110	43	230-240	31-34

### Condenser Water Consumption

Air Temp. Around Ice Machine 90°F/32°C	Water Temperature °F/°C <sup>1</sup>		
	50/10	70/21	90/32
Gal/100 lbs. of Ice	NA	NA	NA

1 Water regulating valve set to maintain 220 PSIG discharge pressure

**SF1200C/RFC1285**  
**REMOTE AIR-COOLED**

Characteristics will vary depending on operating conditions.

<b>24-HOUR ICE PRODUCTION</b>			
<b>Air Temperature Entering Condenser °F/°C</b>		<b>Water Temperature °F/°C</b>	
		<b>50/10</b>	<b>70/21</b>
70	21	1220	NA
90	32	NA	1025

<b>OPERATING PRESSURES (PSIG)</b>			
<b>Air Temperature Entering Condenser °F/°C</b>		<b>Freeze Cycle</b>	
		<b>Discharge Pressure</b>	<b>Suction Pressure</b>
-20 to 50F -29 to 10C		220-230	28-30
70	21	250-270	30-36
80	27	250-270	30-36
90	32	250-275	32-38
100	38	300-330	34-40
110	43	315-340	36-42

**SN1250A****SELF-CONTAINED AIR-COOLED**

Characteristics will vary depending on operating conditions.

<b>24-HOUR ICE PRODUCTION</b>			
<b>Air Temperature Entering Condenser °F/°C</b>		<b>Water Temperature °F/°C</b>	
		<b>50/10</b>	<b>70/21</b>
70	21	1285	NA
90	32	NA	1110

<b>OPERATING PRESSURES (PSIG)</b>			
<b>Air Temperature Entering Condenser °F/°C</b>		<b>Freeze Cycle</b>	
		<b>Discharge Pressure</b>	<b>Suction Pressure</b>
50	10	230-250	28-32
70	21	230-250	30-34
80	27	240-275	30-35
90	32	250-280	31-36
100	38	320-360	33-40
110	43	325-370	34-40

## SN1250W

### SELF-CONTAINED WATER-COOLED

Characteristics will vary depending on operating conditions.

24-HOUR ICE PRODUCTION			
Air Temperature Entering Condenser °F/°C		Water Temperature °F/°C	
		50/10	70/21
70	21	1290	NA
90	32	NA	1160

OPERATING PRESSURES (PSIG)			
Air Temperature Around Ice Machine °F/°C		Freeze Cycle	
		Discharge Pressure	Suction Pressure
50	10	225-230	30-32
70	21	225-230	30-33
80	27	225-230	31-33
90	32	225-230	31-33
100	38	230-235	31-34
110	43	230-240	31-34

### Condenser Water Consumption

Air Temp. Around Ice Machine 90°F/32°C	Water Temperature °F/°C <sup>1</sup>		
	50/10	70/21	90/32
Gal/100 lbs. of Ice	NA	NA	NA

<sup>1</sup> Water regulating valve set to maintain 220 PSIG discharge pressure

**SN1250C/RFC1285**  
**REMOTE AIR-COOLED**

Characteristics will vary depending on operating conditions.

<b>24-HOUR ICE PRODUCTION</b>			
<b>Air Temperature Entering Condenser °F/°C</b>		<b>Water Temperature °F/°C</b>	
		<b>50/10</b>	<b>70/21</b>
70	21	1200	NA
90	32	NA	1020

<b>OPERATING PRESSURES (PSIG)</b>			
<b>Air Temperature Entering Condenser °F/°C</b>		<b>Freeze Cycle</b>	
		<b>Discharge Pressure</b>	<b>Suction Pressure</b>
-20 to 50F -29 to 10C		220-230	28-30
70	21	250-270	30-36
80	27	260-280	30-36
90	32	270-290	32-38
100	38	315-340	36-42
110	43	330-390	38-44

**QF2200/RFC2085**  
**REMOTE AIR-COOLED**

Characteristics will vary depending on operating conditions.

<b>24-HOUR ICE PRODUCTION</b>				
<b>Air Temperature Entering Condenser °F/°C</b>		<b>Water Temperature °F/°C</b>		
		<b>50/10</b>	<b>70/21</b>	<b>90/32</b>
70	21	2150	1980	1840
80	27	2050	1870	1750
90	32	1870	1750	1635
100	38	1650	1530	1410
110	43	1400	1300	1250

<b>OPERATING PRESSURES (PSIG)</b>		
<b>Air Temperature Entering Condenser °F/°C</b>	<b>Freeze Cycle</b>	
	<b>Discharge Pressure</b>	<b>Suction Pressure</b>
-20 to 50F -29 to 10C	220-245 175-185*	14-18
70      21	220-250 210-225*	17-21
80      27	245-270	18-22
90      32	250-275	19-23
100     38	315-330	23-26
110     43	355 -75	25-28

\*Headmaster Part Number 82-5116-3 Only

**QF2300/RFC2385**  
**REMOTE AIR-COOLED**

Characteristics will vary depending on operating conditions.

<b>24-HOUR ICE PRODUCTION</b>				
<b>Air Temperature Entering Condenser °F/°C</b>		<b>Water Temperature °F/°C</b>		
		<b>50/10</b>	<b>70/21</b>	<b>90/32</b>
70	21	2150	1980	1840
80	27	2050	1870	1750
90	32	1870	1750	1635
100	38	1650	1530	1410
110	43	1400	1300	1250

<b>OPERATING PRESSURES (PSIG)</b>			
<b>Air Temperature Entering Condenser °F/°C</b>		<b>Freeze Cycle</b>	
		<b>Discharge Pressure</b>	<b>Suction Pressure</b>
-20 to 50F -29 to 10C		175 – 185	14 – 18
70	21	210 – 225	19 – 21
80	27	225 – 265	20 – 22
90	32	250 – 275	19 – 23
100	38	275 – 305	21 – 26
110	43	300 – 340	22 – 28



# Diagrams

## Wiring Diagrams

The following pages contain electrical wiring diagrams. Be sure you are referring to the correct diagram for the ice machine you are servicing.



### Warning

Always disconnect power before working on electrical circuitry.

## Wiring Diagram Legend

The following symbols are used on all of the wiring diagrams:

- \* Internal Compressor Overload  
(Some models have external compressor overloads)
- \*\* Fan Motor Run Capacitor  
(Some models do not incorporate fan motor run capacitor)
- ( ) Wire Number Designation  
(The number is marked at each end of the wire)
- >>— Multi-Pin Connection  
(Electrical Box Side) —>>—  
(Compressor Compartment Side)

# QF0400 115/60/1 – 230/50/1

(Diagram Shown in Freeze Cycle)

Refer to Nameplate for Voltage Rating

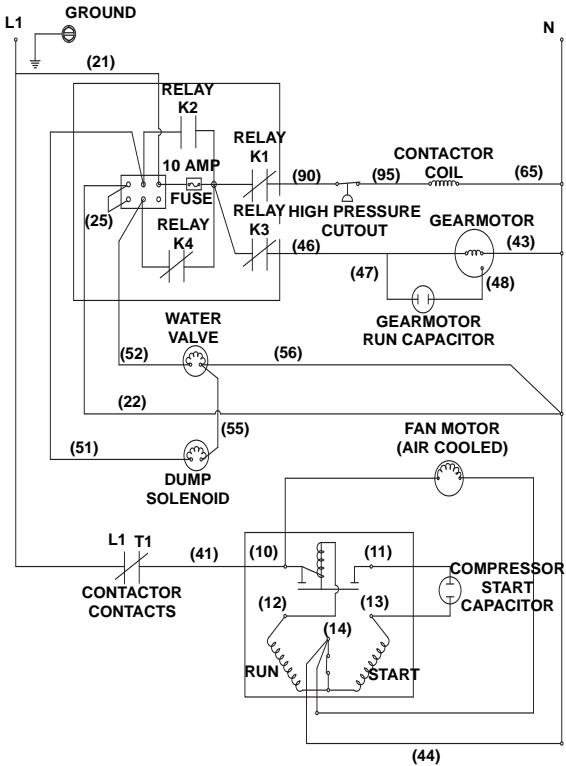

## TOGGLE SWITCH WIRING

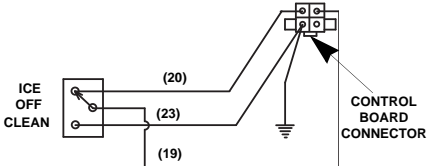

# QC0700/QF0800 115/60/1 – 230/50/1

115/60/1 after Serial Number 050200000

230/50/1 after Serial Number 050100000

(Diagram Shown in Freeze Cycle)

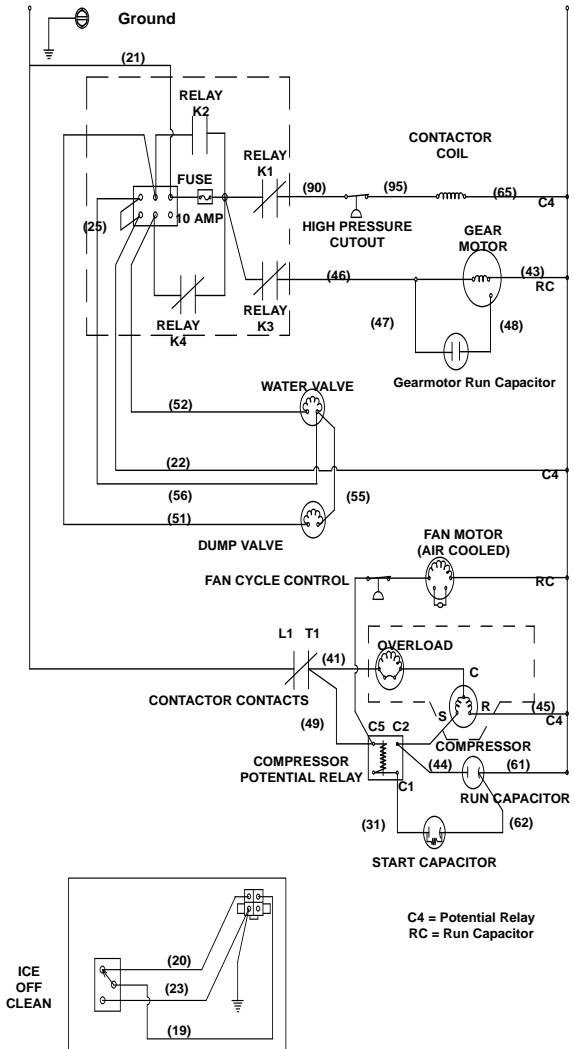

# QC0700/QF0800 115/60/1 – 230/50/1

115/60/1 before Serial Number 050200000

230/50/1 before Serial Number 050100000

(Diagram Shown in Freeze Cycle)

Refer to Nameplate for Voltage Rating

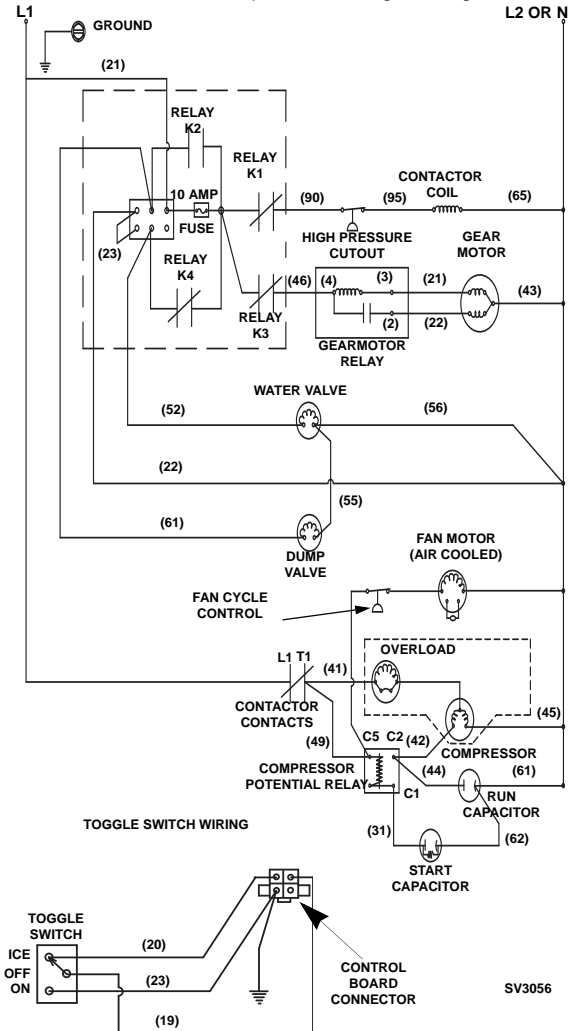

# QC0700/QF0800 COMPRESSOR SECTION

115/60/1 – 230/50/1

(Diagram Shown in Freeze Cycle)

Refer to Nameplate for Voltage Rating

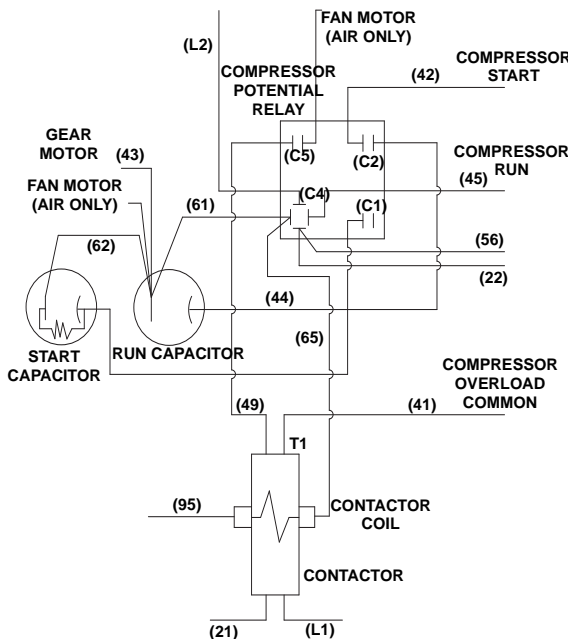

SV2005

# QF2200 115/60/1 – 230/50/1

(Diagram Shown in Freeze Cycle)

Refer to Nameplate for Voltage Rating

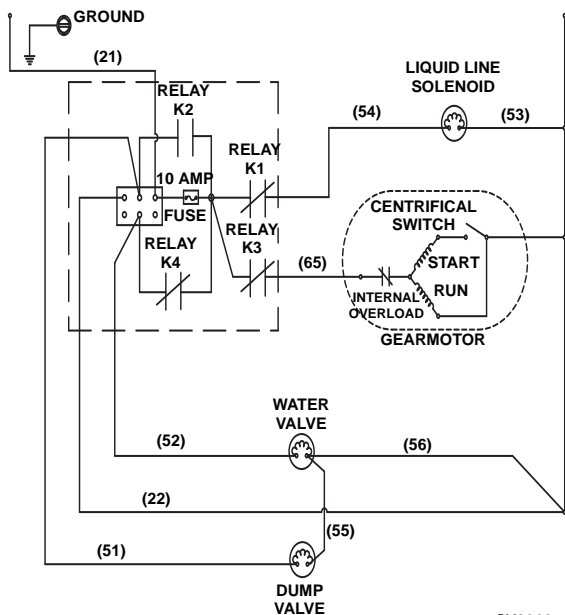

SV3012

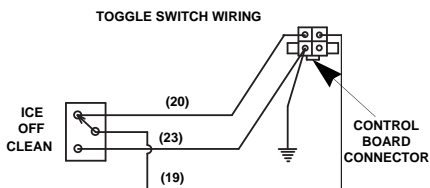



# RFC2085 CONDENSING UNIT 208 - 230/60/3

(Diagram Shown in Freeze Cycle)

Refer to Nameplate for Voltage Rating

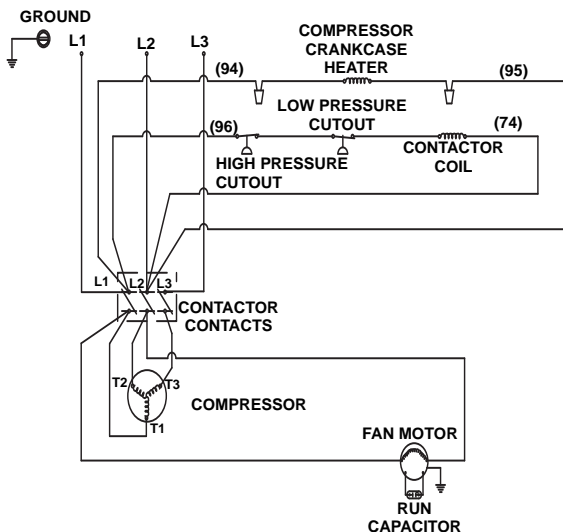

SV3013



# QF2300

115/60/1 – 230/50/1

(Diagram Shown in Freeze Cycle)

Refer to Nameplate for Voltage Rating

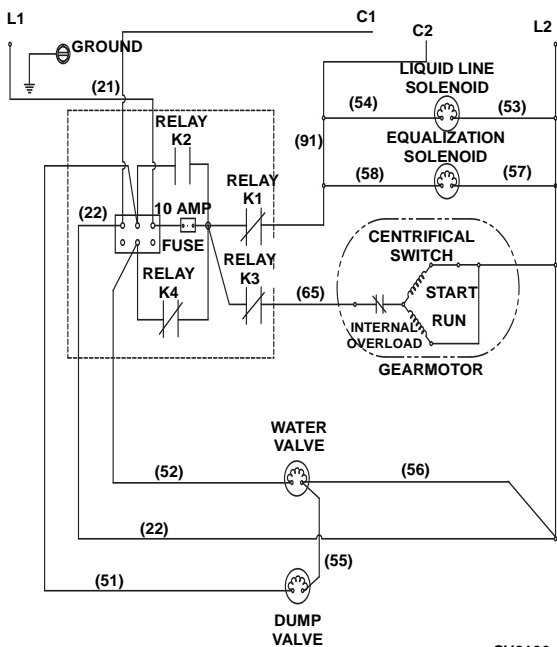

SV2106

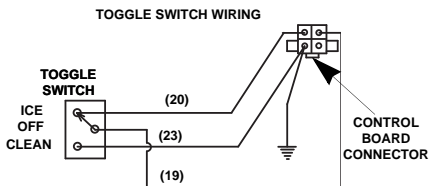

# RFC2385 CONDENSING UNIT

230/60/1 – 230/50/1

(Diagram Shown in Freeze Cycle)

Refer to Nameplate for Voltage Rating

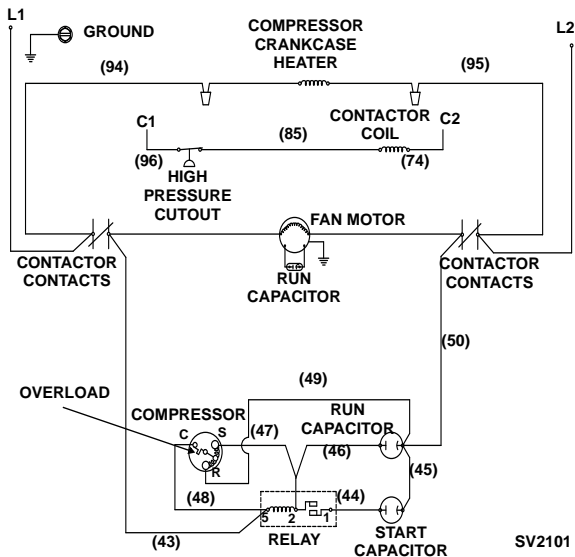

SV2101

# RFC0985/RFC1285/RFC2385 CONDENSING UNIT

208 - 230/60/3

(Diagram Shown in Freeze Cycle)

Refer to Nameplate for Voltage Rating

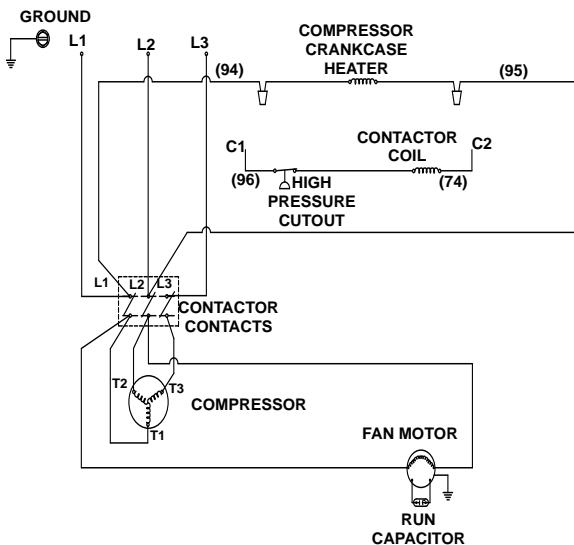

SV2108

# SN012/SN020 115/60/1 – 230/50/1

Refer to Nameplate for Voltage Rating

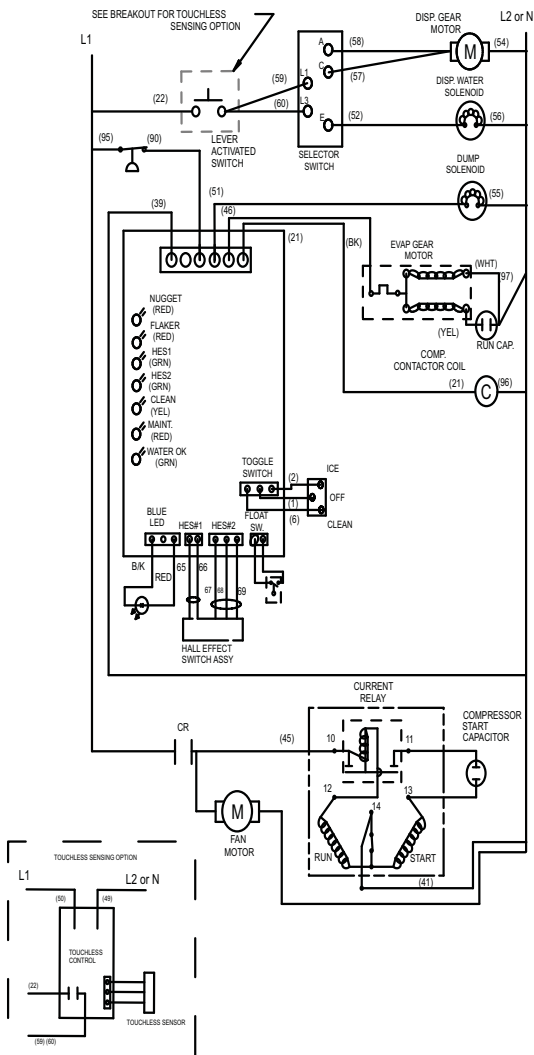

# S MODEL FLAKE / NUGGET HEAD SECTIONS

115/60/1 – 230/50/1

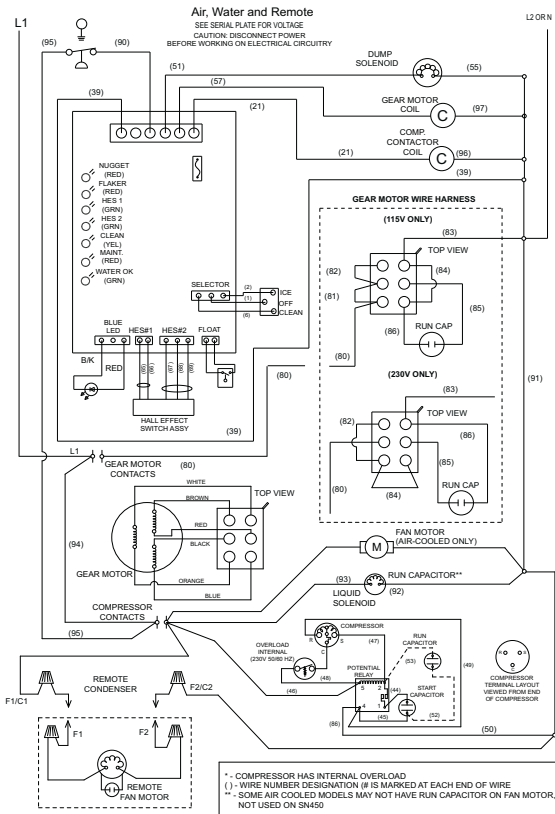

# Electronic Control Boards

## S MODEL FLAKE/NUGGET CONTROL BOARDS

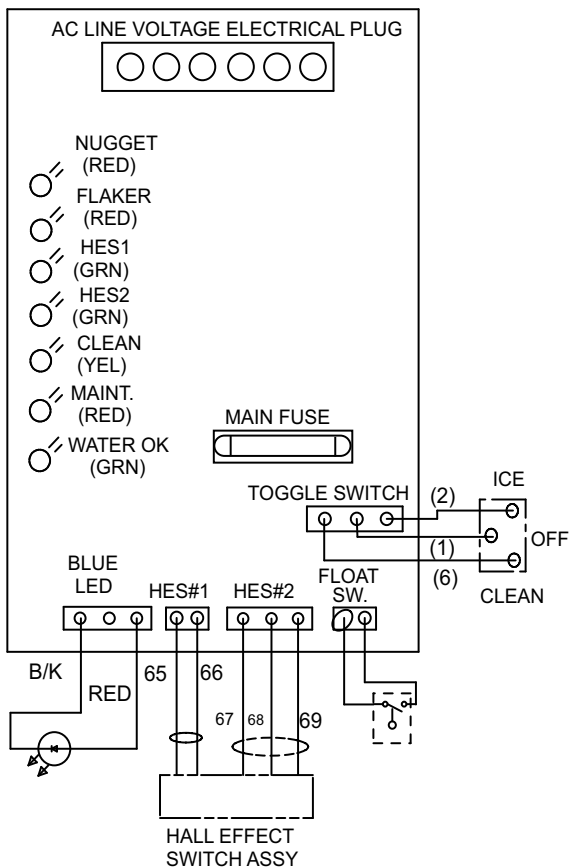

## **Control Board Lights**

#1 Nugget - Red, indicate the control is configured for nugget ice machines.

#2 Flaker - Red, indicates the control is configured for flaked ice machines.

#3 HES #1 - Green, works in conjunction with the Hall Effect Switch #1. When the ice damper is closed the light is on.

#4 HES #2 - Green, works in conjunction with the Hall Effect Switch #2. When the ice damper is closed the light is on.

#5 Clean - Yellow, indicates the unit is in a clean sequence.

#6 Maint. - Red, indicates that maintenance is required. Only used when configured for nugget.

#7 Water - Energizes when the water level in the reservoir closes (raises) the float switch. De-energizes when the float switch opens.

Racing Lights - All lights racing indicates a 5-minute delay period is timing out.

# Q MODEL FLAKE/CHIPLET CONTROL BOARDS

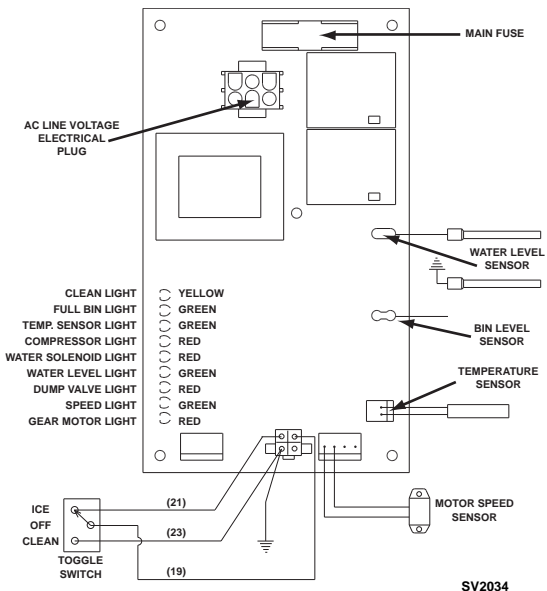



# Refrigeration Tubing Schematics

QF0400/QC0700/QF0800

Air & Water Cooled

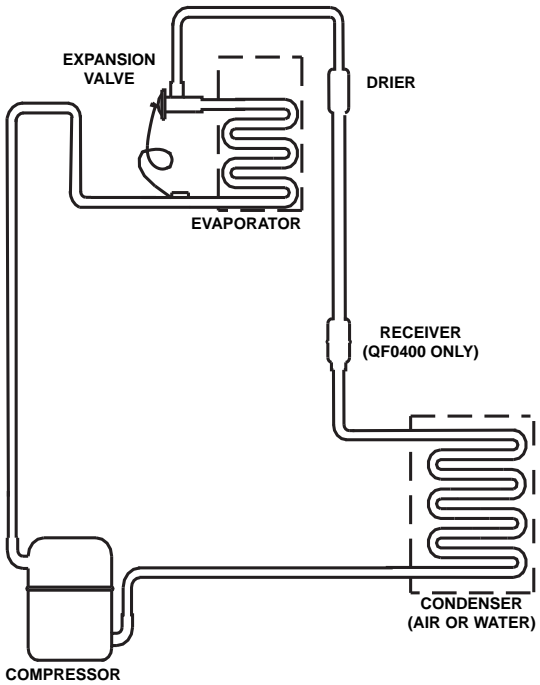

SV3082

# RFC2085

## Remote Air Cooled

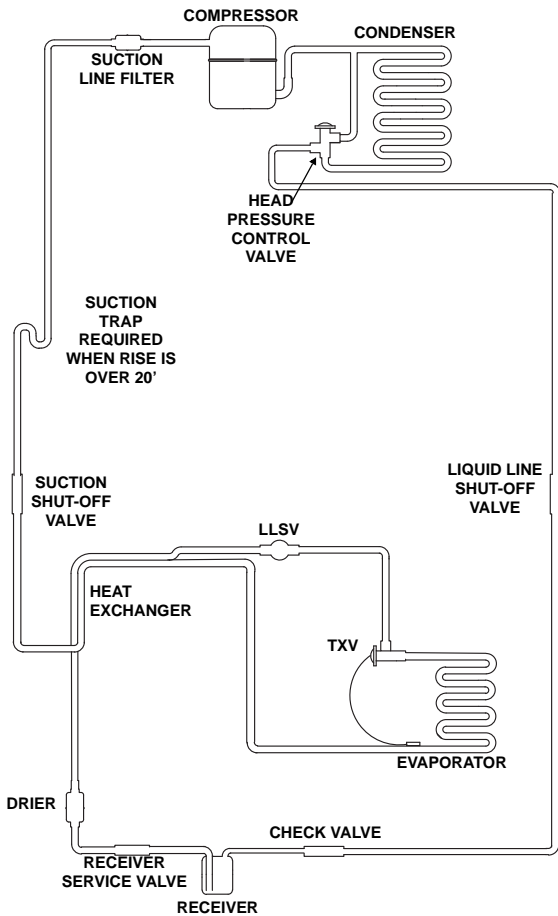

SV3015

# RFC985/RFC1285/RFC2185/RFC2385

## Remote Air Cooled

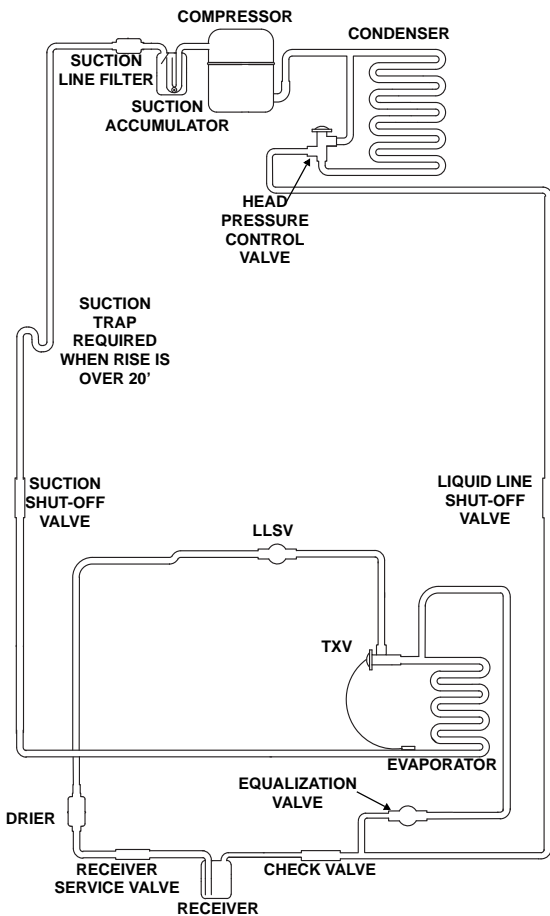

SV2105

SN012/SN020

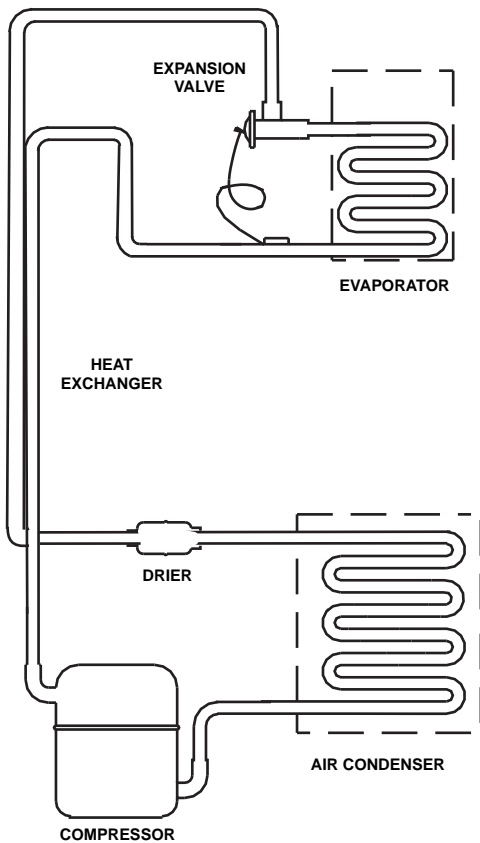

SF0400/SN0450/SF0600/SN0650

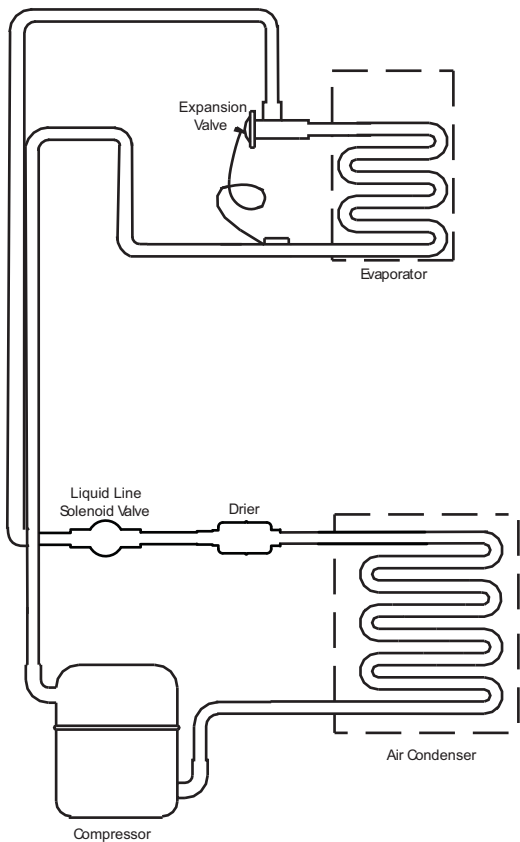

# SF0900/SN0950/SF1200/SN1250

## Air Cooled

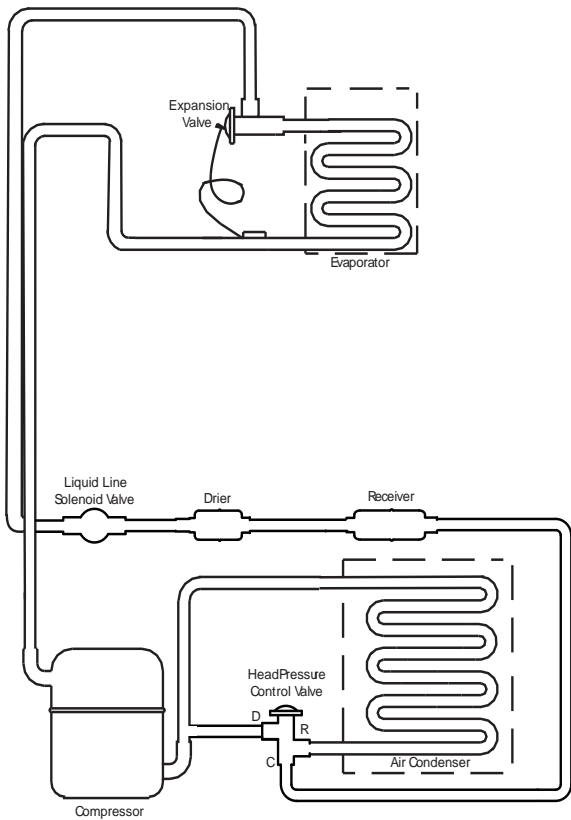

**SF0600/SN0650**  
**Remote Air Cooled**

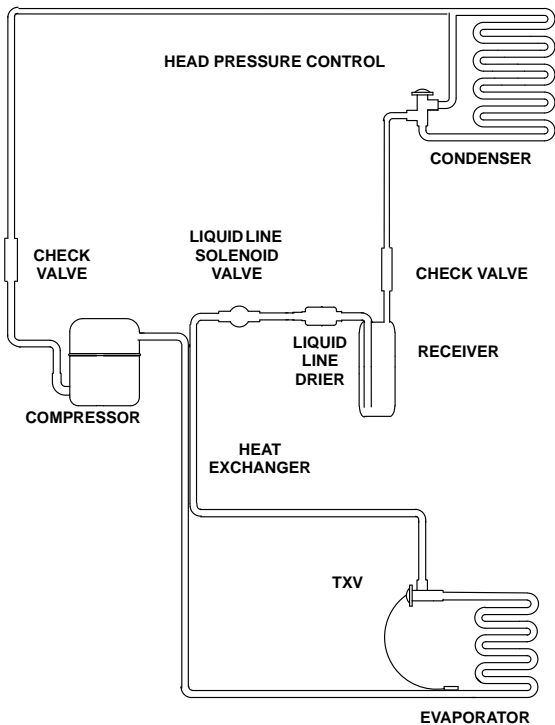

**This Page Intentionally Left Blank**



**This Page Intentionally Left Blank**

**This Page Intentionally Left Blank**





© 2008 Manitowoc  
Part Number 80-1230-9 10/10

**Manitowoc Foodservice**  
2110 South 26th Street, P.O. Box 1720  
Manitowoc, WI 54221-1720, USA  
Ph: 920-682-0161 Fax: 920-683-7589  
Visit us online at: [www.manitowocfsg.com](http://www.manitowocfsg.com)