



SN12 • SN20 Countertop Nugget Ice Maker & Dispenser

Models

- SN-12A
 SN-12AT
 SN-20A
 SN-20AT



SN20

SN12



Three dispense settings are standard: ice only, water only, or ice and water.

- Up to 325 lbs. (147 kgs.) daily ice production.
- Only 16.25" (41.28 cm) wide by 24.00" (61.00 cm) deep by 35.00" (89.00 cm) tall without legs; legs sold separately.
- Nugget ice provides a softer, chewable texture while still providing maximum cooling effect.
- Trouble-free ice dispensing. Simply place cup under chute and activate.
- New and improved components along with 1/3rd less noise.
- Two ice activation options: activation arm or touchless.
- Dispense opening (10.50"/26.67 cm) from grate to chute maximizes clearance for tall containers.
- Larger drain pan minimizes ice spillage.
- Blue LED light provides dispense visibility for rooms with limited ambient light.
- Water and drain connections in back or bottom of unit for flush mounting.
- Manitowoc's patented cleaning technology manages the cleaning process from start to finish.

Warranty

- 2-year parts and labor coverage on all components.
- Additional 3-year (5-year total) parts coverage on ice machine compressor.

Ice Machine Electric

115/60/1. (230/50/1 also available.) 115/60/1 ice machines are factory pre-wired with a 6' (180 cm) power cord and NEMA 5-15P-plug configuration. 230/50/1 ice machines are factory pre-wired with a 6' (180 cm) power cord only, no plug is supplied. Total ampacity: Air-cooled: 10.3 amps. Maximum fuse size: Air-cooled: 15 amps. HACR-type circuit breakers can be used in place of fuses.

Ice Shape

Nugget ice is approximately 3/10" x 3/10" x 1/2" (8 x 8 x 12 mm) with a softer, chewable texture while still providing maximum cooling effect.



Specifications

- BTU Per Hour: 2,300 (average)
Compressor: Nominal rating: 1/3 HP
Refrigerant: R404A
- Operating Limits:
- Ambient Temperature Range: 45°-110°F (7.2°-43.3°C)
 - Water Temperature Range: 45°-90°F (7.2°-32°C)
 - Water Pressure Ice Maker Water In: Min. 20 psi (137.9 kPA) Max. 80 psi (551.1 kPA)





SN12 • SN20 Countertop Nugget Ice Maker & Dispenser

Model	Ice Shape	Ice Production 24 Hours				Power kWh/ 100 lbs. @ 90°/70°F 32°/21°C
		70°Air/50°F Water 21°Air/10°C Water		90°Air/70°F Water 32°Air/21°C Water		
		lbs.	kgs	lbs.	kgs	
SN-12A	nugget	325	148	253	115	7.11
SN-20A	nugget	325	148	253	115	7.11
Water usage/100 lbs./45.4 kgs. of Ice						
Potable Water: 12 gallons, 45.4 liters						

*"A" following model number indicates "Air" condensing unit.

Space-Saving Designs



	SN-12	SN-20
Height*	35.00" 89.00 cm	42.00" 107.00 cm
Width	16.25" 41.30 cm	16.25" 41.30 cm
Depth	24.00" 61.00 cm	24.00" 61.00 cm
Bin Storage	12 lbs. 5.5 kgs.	20 lbs. 9.1 kgs.

*Height without legs. Legs sold separately: K-00345.

SN-12

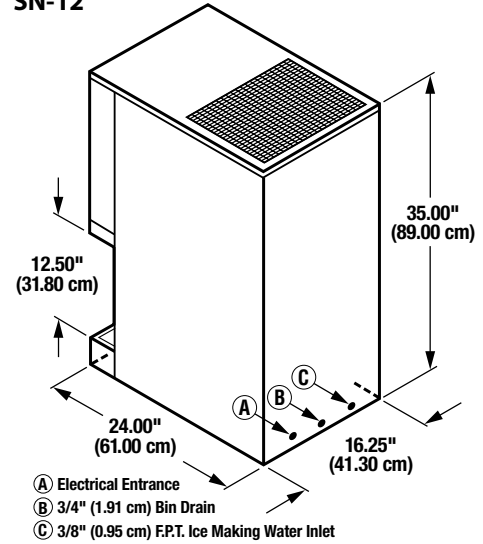

MINIMUM INSTALLATION CLEARANCE –
Top: 24" (60.96 cm); Sides: 8" (20.32 cm); Back: 5" (12.7 cm);
Bottom: 0" (0 cm).



Air Flow Front View

Air in left, air out top.

Front Access

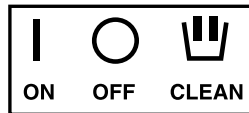

Initiate ice, off and clean operations with simple upfront selector switch. No need to remove front panel.

SN-20

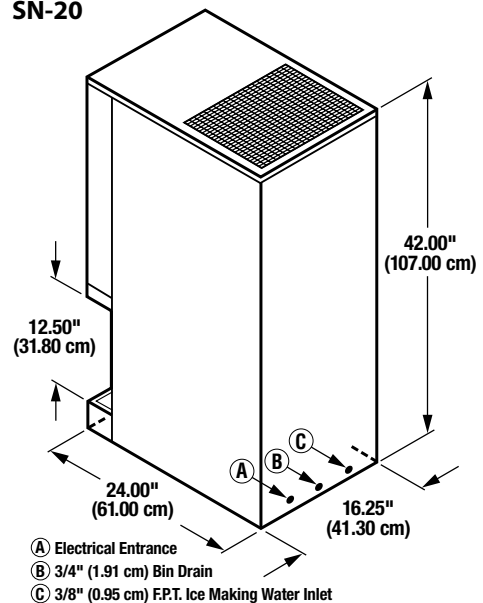

MINIMUM INSTALLATION CLEARANCE –
Top: 24" (60.96 cm); Sides: 8" (20.32 cm); Back: 5" (12.7 cm);
Bottom: 0" (0 cm).

Lever-activated or Touchless Dispensing*

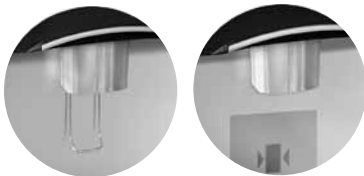

SN-12A

SN-12AT

*Select at time of purchase. K-00377 can be used to convert SN-12A from lever-activated to touchless sensing.