



# RF-1200 Flake Ice Machine

## Model

RF-1200A

RF-1200W



Model RF-1200A  
Flake Ice Machine  
on B-570 Bin

## Standard Features

- Up to 1,186 lbs. (538 kgs) daily flake ice production.
- Flake Ice is perfect for food display, salad bars, and cold therapy/healthcare.
- Ice forms around object without bruising and holds objects in place without tipping/spilling.
- High load capacity bearings for enhanced reliability.
- Heavy duty stainless steel cabinet resists corrosion.

## Warranty

- 3-year Parts.
- 2-year Labor.
- Compressor parts for 5 years and labor for 2 years.

## Specifications

### BTU Per Hour:

Air: 14,000 (average)  
Water: 1,500 (average)

### Compressor:

Nominal rating: 1.5 HP

### Refrigerant:

R-404A

## Ice Machine Electric

208-230/60/1 standard.  
(230/50/1 also available.)

### Maximum circuit ampacity:

15 amps.

### Maximum fuse size:

15 amps.

HACR-type circuit breakers can be used in place of fuses.

### Operating Limits:

- Ambient Temperature Range: Air- and Water-cooled: 50°-110°F (10°-43°C)
- Water Temperature Range: 37°-90°F (3°-32°C)
- Water Pressure Ice Maker Water In: Min. 14 psi (96.5 kPa) Max. 80 psi (551.1 kPa)
- Condenser Inlet Water In: (water-cooled only) Min 20 psi (137.9 kPa) Max 150 psi (1034.2 kPa) Water Condenser not for sea water applications.

## Ice Shape

Combination of small and large bits of ice for presentation and cooling applications.

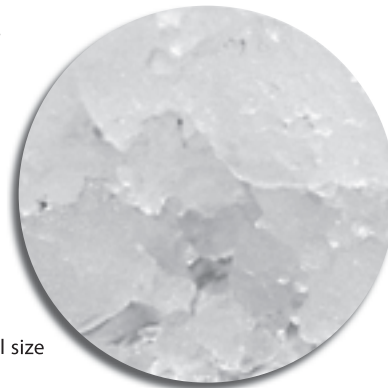

Ice shown actual size



QUALITY MANAGEMENT SYSTEM  
CERTIFIED BY DNV  
ISO 9001:2008



# RF-1200 Flake Ice Machine

## RF-1200 on B-570 Storage Bin

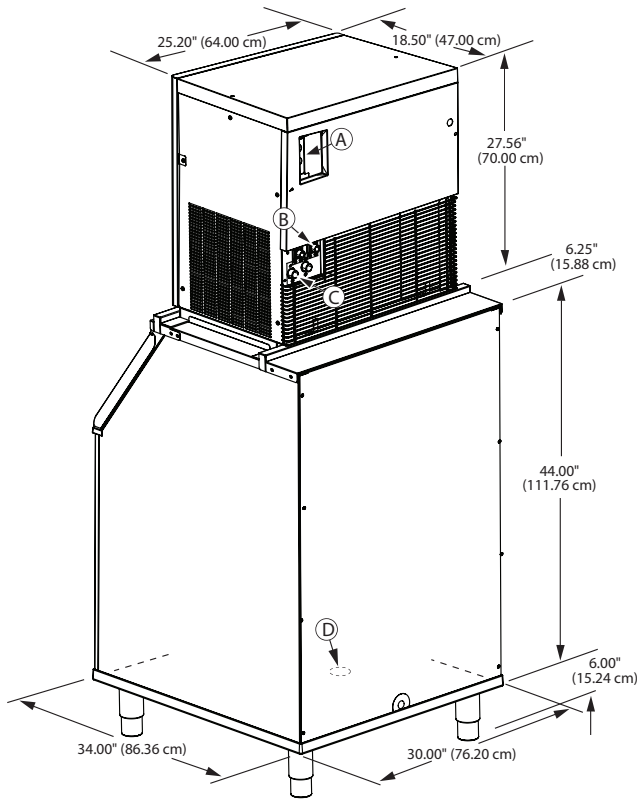

- A Electrical Entrance (2) Options
- B 3/8" (0.95 cm) N.P.T. Ice Making Water Inlet
- C 1/2" (1.27 cm) N.P.T. Water Drain
- D 3/4" (1.91 cm) Bin Drain

**Installation Note - Minimum installation clearance:**  
 Top/sides: 8" (20.32 cm), back: 5" (12.70 cm).

## Space-Saving Design



RF-1200 on B-570	
Height	77.56" 197.00 cm
Width	30.00" 76.20 cm
Depth	34.00" 86.36 cm
Bin Storage	430 lbs. 195 kgs

Height includes adjustable bin legs  
 6.00" to 7.00" (15.24 to 17.78 cm)  
 set at 6.00" (15.24 cm).

## Accessories

K-00405 48" B Style Bin Adapter\*

\*adapter not for use with Large Capacity Bins.

## Standard Equipment

K-00404 30" B-Style Bin Adapter

## Air Flow Overhead View

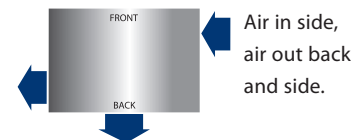

	Model	Ice Shape	Ice Production 24 Hrs.		Power kWh/ 100 lbs. 90°/70°F	Water Usage (100 lbs./45.4 kgs of Ice)	
			70° Air/50°F Water 21° Air/10° C Water	90° Air/70°F Water 32° Air/21° C Water		Potable Water	Condenser Water
Air-Cooled	RF-1200A	Flake	1,186 lbs.	864 lbs.	5.63	12 gal.	N/A
			538 kgs	392 kgs		45.4 L	N/A
Water-Cooled	RF-1200W	Flake	1,204 lbs.	1,004 lbs.	4.11	12 gal.	103 gal.
			546 kgs	455 kgs		45.4 L	390 L

