

Mobile Handwashing Stations

Stainless Steel



Model 9600



Model 9620



Interior view of Model 9610

Ideal for remote serving locations where hand sanitation is required.

- Built-in fresh water supply and waste water storage.
- Sink and cabinet are constructed of durable, easy to clean and sanitize stainless steel.
- Warm and cold water versions available
- Sink bowl is 10" x 12" x 5" (254 x 305 x 127 mm) deep.
- Heavy duty faucet(s) is (are) chrome plated brass with convenient on/off wrist blade control(s).
- Chrome plated soap dispenser is securely mounted next to the sink.
- Locking door latch prevents unauthorized access to the interior.
- Rolls smoothly on 4 ea. tough-duty 5" (127 mm) No-Mark® cushion tread swivel casters (2 each with brake).

Spec. # _____

AIA # _____

Specifications

Shall be Model 9600 (or Model 9610), and shall feature welded stainless steel cabinet construction. Unit shall have one (two) each removable 5-gallon tank(s) for fresh water supply, and one (two) each 7-gallon tank(s) for waste water storage. Top shall feature drop-in stainless steel sink bowl with drain and pump soap dispenser. Faucet shall be chrome plated brass with wrist blade control(s). Built-in water pump shall be 150 psi, 115 VAC, 0.9 amp, with automatic demand (no priming required), and shall feature backflow protection to prevent fresh water contamination. Access door shall feature recessed paddle latch with security key lock. A heavy-duty roll towel bar shall be mounted to the cabinet side. Bottom corner bumpers shall be standard on Model 9600 and 9620. Casters shall be 5" non-marking, two each fixed and two each swivel with brake.

Model 9610, 9620:

Shall have built-in 2½-gallon electric 1500 watt water heater (120 VAC, 12.5 amp), featuring adjustable thermostat (110°F to 170°F), corrosion-resistant bronze tank, on/off switch, 150 psi operating pressure, and replaceable heating element.



Lakeside Manufacturing, Inc.

4900 West Electric Avenue • West Milwaukee, WI 53219 U.S.A.

800-558-8565 • 414-902-6400 • Fax 414-902-6446 • www.eLakeside.com

Mobile Handwashing Stations

Stainless Steel

Spec. #

A/A #

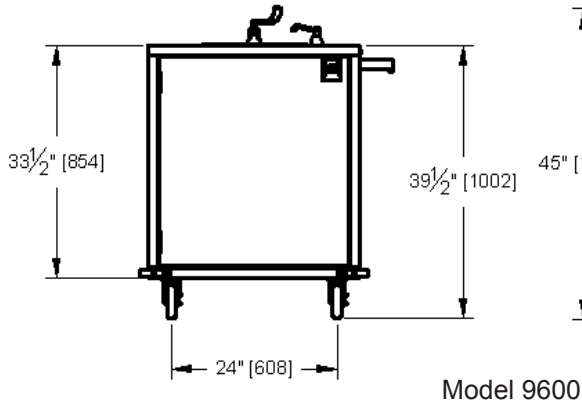
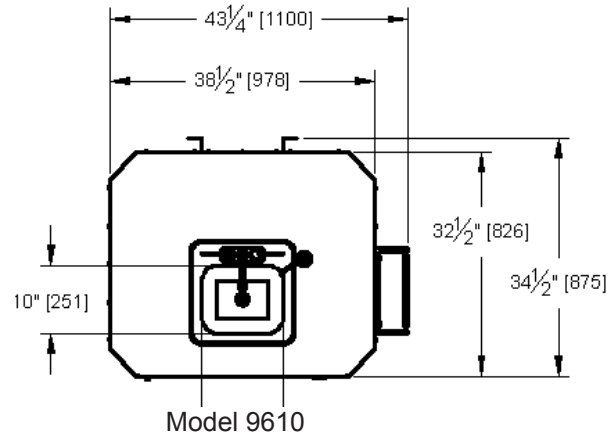
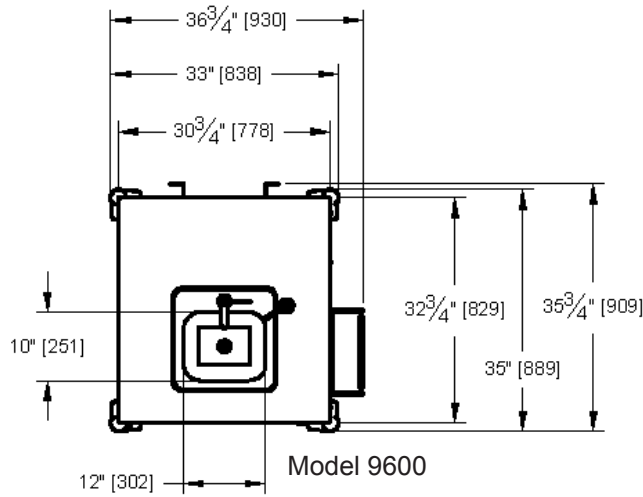

Model 9600

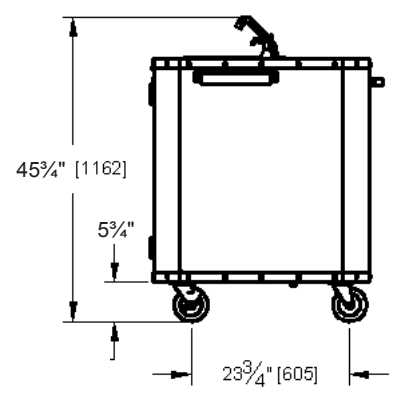
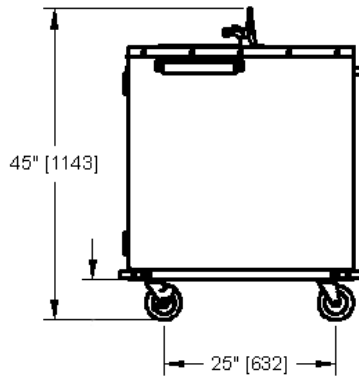

Model 9610

Dimensions

Model	Water Supply	Fresh Water Cap.	Waste Water Cap.	Overall Size			Unit Wt.* Lbs.	Ship Wt. Lbs.
				W	L	H		
9600	Cold	5 Gal.	7 Gal.	33" (838)	35" 889	45" 1143	189 (85.1 kg)	222 (100 kg)
9610	Warm/Cold	10 Gal.	14 Gal.	32 1/2" (825)	38 1/2" 978	45 1/4" 1162	205 (92.3 kg)	238 (107 kg)
9620	Warm	5 Gal.	7 Gal.	23 1/2" (597)	29 3/4" 756	43 1/4" 1099	126 (56.8 kg)	148 (67.3 kg)

Measurements in () denote metric millimeters, unless otherwise specified.

*Without water.

Options

- Extra supply and waste water tanks (Model 9600)
- Deluxe fold towel dispenser
- Vinyl or laminate finish



Optional fold towel dispenser
Models 9600, 9610



Optional fold towel dispenser
Model 9620



Lakeside Manufacturing, Inc.

4900 West Electric Avenue • West Milwaukee, WI 53219 U.S.A.

800-558-8565 • 414-902-6400 • Fax 414-902-6446 • www.eLakeside.com