

Stainless Steel Utility Carts

Medium Duty - 500 Lb. Capacity



Model 444

Ideal For All-Purpose Back-Of-The-House Tasks.

- Durable, unitized electronically welded angle leg frame.
- 20 gauge stainless steel reinforced shelves.
- Protective bumpers on legs and handle safeguard furnishings.
- Sound deadening panels under shelves restrict vibrations and noise.
- 500 lbs. (230 kg.) capacity

Spec. #

AIA #

Specifications

Unit shall be of fully welded unitized construction with an overall carrying capacity of 500 pounds. Corner legs shall be of 16-gauge angle stainless steel. Shelves shall be of 20-gauge stainless steel with long shelf edges double hemmed for extra strength, and shall be electronically spot welded to upright legs at all points. Unit shall have a stainless steel push handle welded to frame, and shall have corner bumpers mounted to front legs and ends of push handle. Unit shall have an independent galvanized steel dolly frame fastened to the bottom with 8 screws. Four each 4" swivel casters shall be mounted to the dolly frame.

Models 444 and 459 Only

Unit shall have 4 each 5" diameter swivel casters with non-marking polyurethane wheels. Welded assembly shall have triangular stainless steel reinforcing gussets welded to four bottom corners. Top shelf shall have 16-gauge angle reinforcements welded to long shelf edges.

LAKESIDE[®]
Ingenuity On Wheels™

Lakeside Manufacturing, Inc.

4900 West Electric Avenue • West Milwaukee, WI 53219 U.S.A.

800-558-8565 • 414-902-6400 • Fax 414-902-6446 • www.eLakeside.com

Stainless Steel Utility Carts

Medium Duty - 500 Lb. Capacity

Optional Accessories

(all models)

- Perimeter shelf mounted strip bumper
- Set of two each brake casters
- Cushion tread wheels
- Clear vinyl slipover box type cover

(models 444 and 459)

- Extended perimeter bumper
- 8y swivel casters

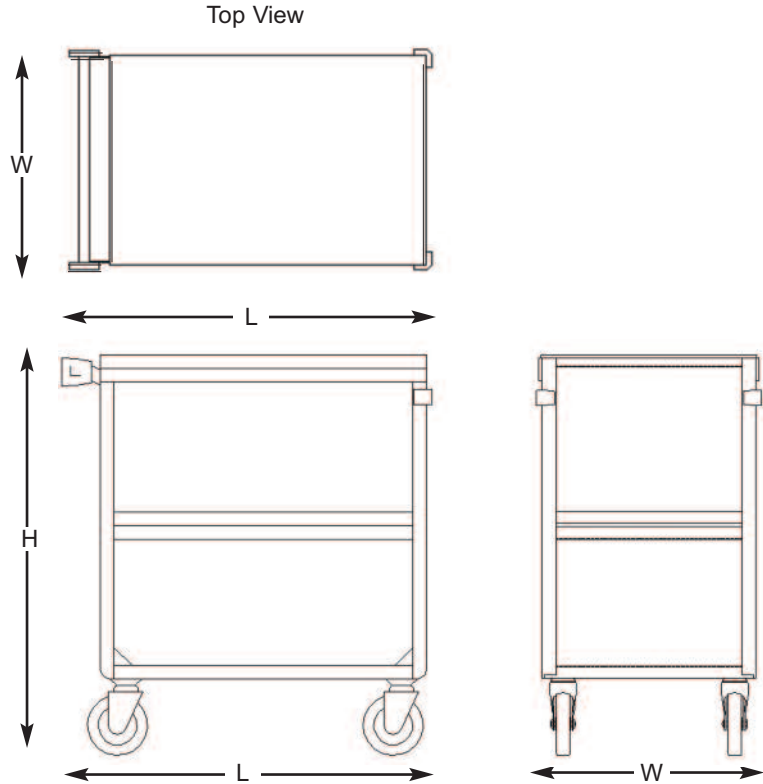

AutoCAD drawings available through KCL CADalog

Dimensions

| Model | # of | Shelf Description | | Overall Size | | | Lake-Glide® Casters | | Case Weight lbs. (kg.) |
|-------|------|------------------------------|------------------|------------------|-------------------|------------------|----------------------|----------------------|---------------------------|
| | | Size | Clearance | W | L | H | Type | Dia. | |
| 411 | 3 | 15-1/2" x 24" (394 x 610) | 11-7/8" (302) | 16-3/4" (425) | 27-5/8" (702) | 33-3/8" (848) | All swivel | 4" (102) | 39 (17.7) |
| 422 | 3 | 18" x 27" (457 x 686) | 11-7/8" (302) | 19" (483) | 31" (787) | 33-3/8" (848) | All swivel | 4" (102) | 42 (19.1) |
| 444 | 3 | 21" x 35" (533 x 889) | 13-1/8" (333) | 22-3/8" (568) | 39-1/4" (997) | 37-1/4" (946) | All swivel* | 5" (127) | 68 (30.8) |
| 459 | 3 | 21" x 49" (533 x 1245) | 13-1/8" (333) | 22-3/8" (568) | 54-1/8" (1374) | 37-1/4" (946) | 2 swivel 2 fixed* | 5" (127) 5" (127) | 88 (39.9) |

Measurements in () denote metric millimeters, unless otherwise specified.



Lakeside Manufacturing, Inc.

4900 West Electric Avenue • West Milwaukee, WI 53219 U.S.A.

800-558-8565 • 414-902-6400 • Fax 414-902-6446 • www.eLakeside.com