

# Krowne

ROYAL SERIES

## 8" Center Wall Mount Pre-Rinse

Model: 17-108W

Item #: \_\_\_\_\_ Quantity: \_\_\_\_\_

Project: \_\_\_\_\_

NSF®

Plumbing

QUICK  
CONNECT

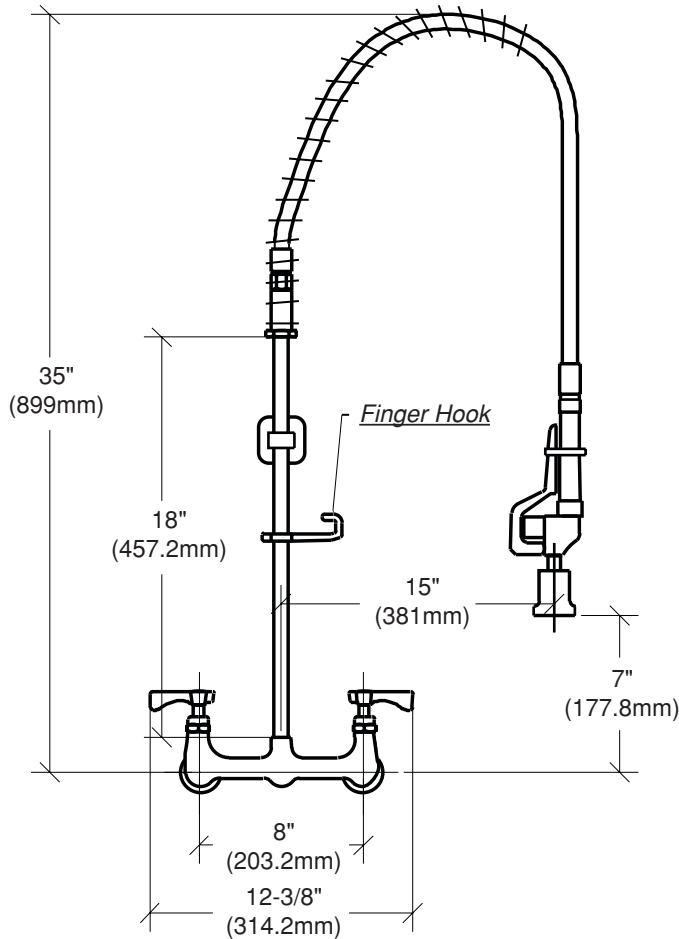

Front View

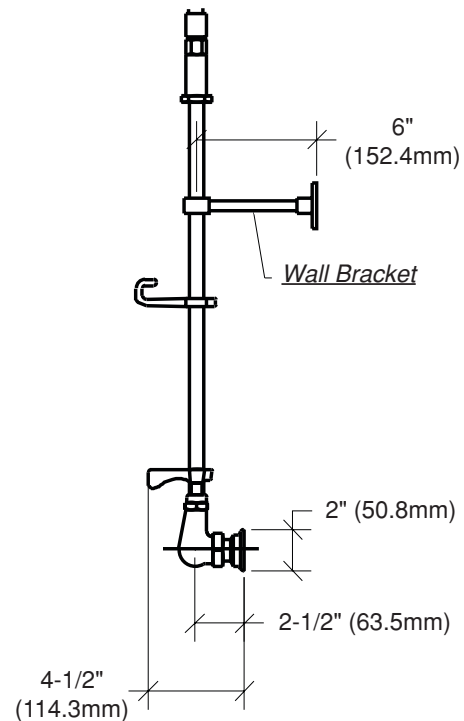

Side View

### FEATURES:

- 1/4 TURN HIGH PERFORMANCE CERAMIC CARTRIDGE VALVES WITH BUILT IN BACK FLOW PREVENTORS
- HEAVY DUTY FLANGES WITH ECCENTRIC FITTINGS FOR QUICK INSTALLATIONS
- MOUNTING KIT INCLUDED (1/2" NPT x 1 1/2" MALE NIPPLES WITH LOCK NUTS)
- PRE-ASSEMBLED AT FACTORY TO CUT INSTALLATION TIME
- 44" HEAVY DUTY STAINLESS CLAD FLEXIBLE HOSE. TESTED TO 400 PSI
- WALL BRACKET INCLUDED
- FULL REPLACEMENT PARTS AVAILABLE
- 1 YEAR WARRANTY

### SPECS:

- 8" ON CENTER WALL MOUNT WITH 1/2" NPT FEMALE INLETS
- ROUGH IN: TWO 7/8" ROUND HOLES ON 8" CENTERS
- WATER SAVER SPRAY HEAD, 1.5 GPM @ 60 PSI FLOW RATE COMPLIES WITH EPACT 2005
- 3/8" NPT x 18" RISER PIPE WITH HOOK. PRE-ASSEMBLED TO BASE AT FACTORY
- TEMP RANGE: 40°F TO 180°F
- SHIPPING WEIGHT: 13 LBS

Approved By: \_\_\_\_\_

Due to our commitment to continued product improvement, specifications are subject to change without notice.

**Krowne** Metal Corporation

100 Haul Road Wayne, New Jersey 07470

www.krowne.com

Phone: 800-631-0442

FAX: 973-872-1129