

KMD-901M_H

MODULAR CRESCENT CUBER

Item # _____

Project: _____

Qty: _____

*AutoCad available on KCL

KMD-901M_H

6/11

Item # 13221

CUBER DIMENSIONS

W x D x H

KMD-901M_H
30 x 24^{5/8} x 28





KMD-901MWH

Water-Cooled
Shown on an optional
Lancer 30" Dispenser

KMD-901MRH

Remote Air-Cooled

- Up to 876 lbs. of ice production per 24 hours
- Ice on beverage design
- Durable stainless steel exterior
- Individual crescent cube
- Protected by *H-GUARD Plus* Antimicrobial Agent 
- CycleSaver® Design 
- EverCheck® alert system 
- Stainless steel evaporator
- R-404A Refrigerant

* The KMD-901MRH is ENERGY STAR qualified.

Warranty

Valid in United States, Canada, Puerto Rico, & U.S. Territories. Contact factory for warranty in other countries.

Three Year - Parts & Labor on entire machine.

Five Year - Parts & Labor on: Evaporator.

Five Year - Parts on: Compressor, air-cooled condenser coil.



ISO 9001-5:2008

© HOSHIZAKI AMERICA, INC.

618 Hwy. 74 S., Peachtree City, GA 30269

TEL 1-800-438-6087

FAX 1-800-345-1325

www.hoshizaki.com



KMD-90IM_H MODULAR CRESCENT CUBER

DIMENSIONS
W x D x H
KMD-90IM_H
30 x 24^{5/8} x 28

- Water-cooled
- Remote Air-cooled

WATER-COOLED

Water Temp ° F.	50°	70°	90°
Air Temp ° F.			
70°	876	874	831
80°	875	872	805
90°	874	870	812

REMOTE AIR-COOLED

Water Temp ° F.	50°	70°	90°
Air Temp ° F.			
70°	848	827	768
80°	832	798	723
90°	827	775	705

UTILITY CONSUMPTION

Model Number	Ice Production Per Cycle		KWH per 100 LBS. 90/70	Potable Water Gal. per 100 lbs. 90/70	Condenser Water Gal. per 100 lbs. 90/70
	Lbs.	Cubes			
KMD-901MWH	12.3	624	4.2	24.5	125
KMD-901MRH	12.0	624	5.3	20.0	N/A

SPECIFICATIONS

Model Number	Condenser	Amperage	Min. Circuit Ampacity	Shipping Weight
KMD-901MWH	Water-Cooled	7.8	20	251 lbs.
KMD-901MRH	Remote Air-Cooled	10.0	20	258 lbs.

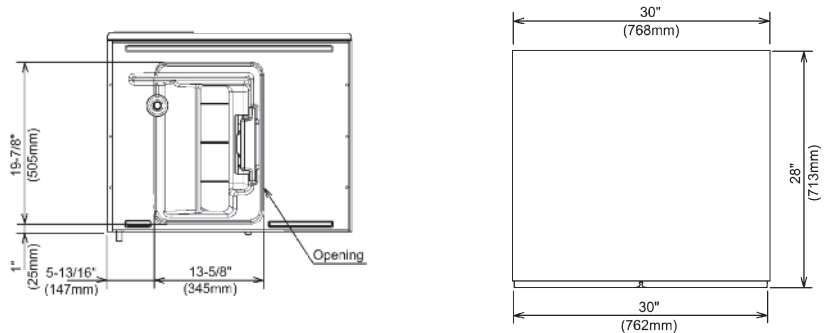

ICE DROP ZONE (KMD-901MWH & KMD-901MRH)

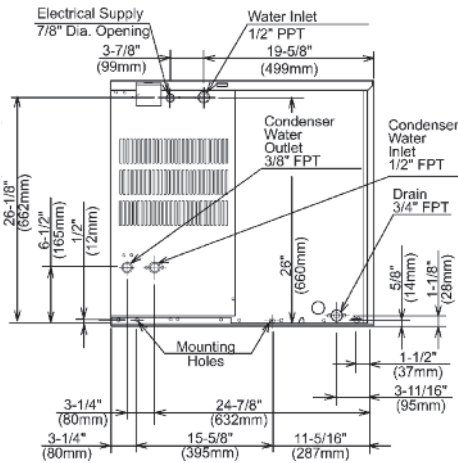

WATER-COOLED UNIT
(KMD-901MWH)

FRONT VIEW
(KMD-901MWH & KMD-901MRH)

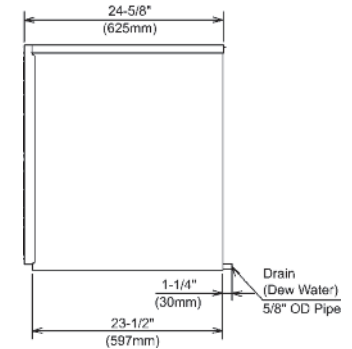

SIDE VIEW (KMD-901MWH
& KMD-901MRH Unit)

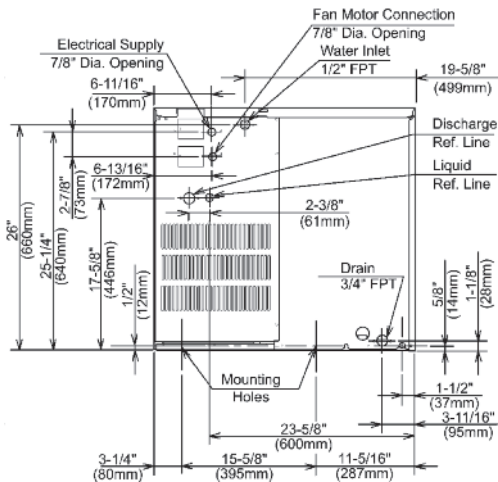

REMOTE AIR-COOLED UNIT
(KMD-901MRH)

URC-9F Remote Condenser (Sold Separately)
For Use with KM-901MRH

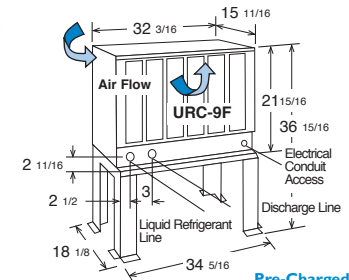

Pre-Charged Tubing Kits
(Sold Separately)
20' R404-2068-2
35' R404-3568-2

Voltage supply for the URC Remote Condenser is supplied from the Ice Maker. No additional circuit is required.



ELECTRICAL & PLUMBING/KMD-90IM_H

- 208-230V/60/1 (3 wire with dedicated neutral for 115V)
- 20 amp Max Fuse/HACR Breaker Size
- 1/2" OD copper or equivalent independent potable water supply
- 3/4" FPT independent drain connection
- 5/8" OD pipe



© HOSHIZAKI AMERICA, INC.

618 Hwy. 74 S., Peachtree City, GA 30269

OPERATING LIMITS

- Ambient Temp Range 45 - 100°F
- Water Temp Range 45 - 90°F
- Water Pressure 10 - 113psig
- Voltage Range 187 - 253V

CONDENSING UNIT

- Voltage Range 104 - 127V
- Ambient Temp Range -22 - 122°F

SERVICE

- Panels easily removed and all components accessible for service.

TEL 1-800-438-6087

FAX 1-800-345-1325

www.hoshizaki.com

Printed in U.S.A.

