

HOBART701 S Ridge Avenue, Troy, OH 45374
1-888-4HOBART • www.hobartcorp.com**4246
MIXER-GRINDER****HOBART****STANDARD FEATURES**

- 140 Lb. Hopper Capacity, 55 to 60 lb. per Minute Output
- Exclusive WEDGE Cylinder Insures Full Rate Feeding for the Entire Batch
- Grind Motors –
 - 4246S - 5 H.P.
 - 4246HD - 7½ H.P.
- 1 H.P. Mix Motor
- Grinder Hooper Constructed of Glass Bead Finished Stainless Steel
- Stainless Steel Panels Enclose the Base Assembly and Motors; Mixing Arm and Conveyor Screw are Tinned, End Ring and Cylinder are Stainless Steel
- Nickel Chrome Plated Legs
- Up-Front, Easy-To-Reach Controls
- Easily Converted Hopper Lid for Right or Left Side Hopper Loading
- Pneumatic Foot Control Option

VOLTAGES

- 208/60/3
- 380-415/50/3

**MODELS**

- 4246S – Standard Mixer-Grinder
- 4246HD – Heavy-Duty Mixer-Grinder

OPTIONS

- 7½ H.P. Grind Motor (Model 4246HD for mixed fresh and frozen applications) (not available in 208-240/60/1 electrical spec)
- Pneumatic Foot-Control
- Non-Adjustable Legs with Casters - 7⅝" (same height as stationary legs)
- Adjustable Legs with Casters in Two Different Height Ranges (Heights are measured from floor to base of frame):
 - Short - 9¾" - 12¼"
 - Long - 12⅜" - 17½"

Specifications, Details and Dimensions on Reverse Side.

**4246 MIXER-GRINDER**

4246 MIXER-GRINDER



701 S Ridge Avenue, Troy, OH 45374
1-888-4HOBART • www.hobartcorp.com

SPECIFICATIONS

GENERAL: The standard machine has a 5 H.P. grind motor, 1 H.P. mix motor, non-adjustable stationary legs, and an 8-foot length cord and plug power connection. Available voltages are 208/60/3 and 380-415/50/3 (only for 7½ H.P.).

ELECTRICAL CONTROLS: Electrical controls consist of waterproof start and stop switches, magnetic contactors, dual motor overload protection and foot switch operation capability. An electrical interlock switch is provided. Whenever the hopper lid is opened, power to the motors is shut off. The hopper lid must be in its proper operating position before the grinder motors can be started.

CAPACITY: The 4246 Mixer-Grinder hopper has meat capacity up to 140 pounds depending on the type of product. The grinding rate is 55 to 60 pounds of fresh boneless beef per minute, first or second cutting through a ⅛" plate; 60 to 65 pounds of pork per minute second cutting through a ⅜" plate. The 4246HD is for fresh or frozen meat tempered to 24°F or higher and can be in flake or stick form.

GRINDING END: The mixer-grinder is equipped with a "Wedge cylinder" grinding end. This grinding end is sized for #32 knives and plates (not included but optionally available).

FEEDING SYSTEM: The 4246 is powered by two separate drive systems. A 1 H.P. motor drives the heavy-duty steel mixing arm. The arm rotates at 23 rpm and can easily be removed from the hopper for cleaning. The conveyor screw extends the full length of the hopper and the cylinder. The screw rotates at a speed of 194 rpm and it is driven by a 5 H.P. motor in the standard unit (4246S); the motor in the heavy-duty unit (4246HD) is a 7½ H.P. motor. By depressing the MIX/GRIND START button both the mixing arm and the screw are operated. Both mixing and grinding are stopped when the STOP switch is depressed.

CLEANING: The mixing arm, conveyor screw, cylinder, and conveyor screw drive-shaft seal are removable from the grinder for cleaning.

FINISH: The grinder consists of glass bead finished stainless steel hopper; stainless steel panels to enclose the base assembly and motors. The mixing arm and conveyor screw are tinned. The end ring and cylinder are stainless steel. The legs are nickel chrome plated.

DETAILS AND DIMENSIONS

LEG	DIM 'A'	DIM 'B'	DIM 'D'	DIM 'F'
STANDARD & CASTER	7 ¹⁵ / ₁₆ "	24 ⁷ / ₁₆ "	49 ¹⁵ / ₁₆ "	71 ⁵ / ₁₆ "
SH ADJ CASTER (MIN)	10 ¹ / ₁₆ "	26 ⁷ / ₁₆ "	52 ¹ / ₁₆ "	73 ⁷ / ₁₆ "
SH ADJ CASTER (MAX)	12 ¹ / ₄ "	28 ³ / ₄ "	54 ¹ / ₄ "	75 ⁵ / ₈ "
LG ADJ CASTER (MIN)	12 ¹¹ / ₁₆ "	29 ⁹ / ₁₆ "	54 ¹¹ / ₁₆ "	76 ¹ / ₁₆ "
LG ADJ CASTER (MAX)	17 ¹ / ₂ "	34"	59 ¹ / ₂ "	80 ⁵ / ₈ "

ELECTRICAL SPECIFICATIONS	NEMA CONFIGURATION	
	CONNECTOR	RECEPTACLE
208/60/3	L21 - 30P	L21 - 30R

WARNING

ELECTRICAL AND GROUNDING CONNECTIONS MUST COMPLY WITH THE NATIONAL ELECTRICAL CODE AND/OR OTHER LOCAL ELECTRICAL CODES IN FORCE.

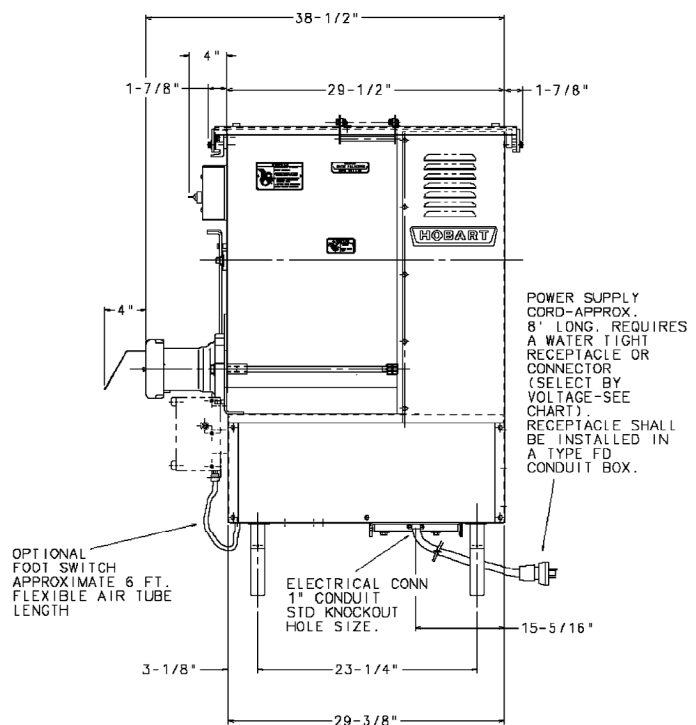
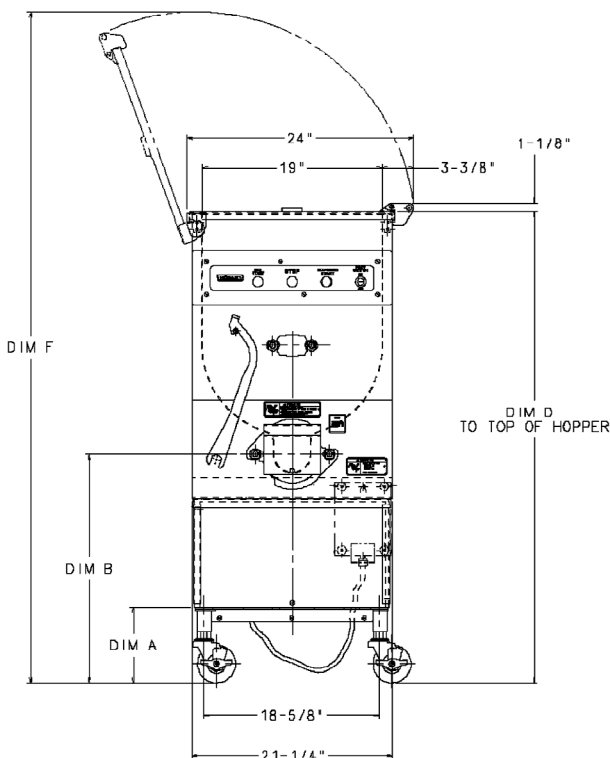

As continued product improvement is a policy of Hobart, specifications are subject to change without notice.