



## Floor Kettles model DH

### Description

Kettle shall be a Groen Model DH (specify 20, 40, or 60) gallon stainless steel steam jacketed unit, operating with a self-contained gas heated steam source contained within the unit, per Bulletin 144242 as follows:

### Construction

Kettle shall be of 18.8 type 304 stainless steel, 316 stainless steel interior solid one-piece welded construction. The console and all exposed surfaces shall be stainless steel. All controls shall be mounted on the front panel except the thermostat, which is mounted on the trunnion support arm.

The kettle body shall be mounted in a heavy-duty stainless steel combination kettle support tilt trunnion, which in turn, is supported by the stainless steel enclosed base. The base shall be provided with stainless steel tubular legs with adjustable bullet feet. The enclosed support base shall contain a smooth operating, self locking tilt mechanism, and shall be of sanitary, drip-proof construction, with interior readily accessible for installation or maintenance.

The unit shall be furnished with a heavy reinforced bar rim with a welded in butterfly shaped pouring lip for maximum sanitation and durability. Faucet mounting bracket is standard.

### Finish

Kettle interior shall be polished to a 180 emery grit finish. Exterior of kettle shall be finished to a bright high buff finish, ensuring maximum ease in cleaning and maintaining brilliant appearance.

### A.S.M.E. Code, A.G.A. Design Certified

Unit shall be A.S.M.E. shop inspected, stamped and registered with the National Board for operation up to a maximum working pressure of 50 PSI. Unit shall be design certified by the American Gas Association. (Natural and Propane only.)

### Sanitation

Unit shall be designed and constructed to meet NSF and known health department and sanitation codes. and be NSF listed.

### Drawoff

A 2" tangent drawoff is optional. (Add "T" to model designation DHT). If drawoff is specified, outlet shall be equipped with removable 1/4" perforated stainless steel strainer.

### Self-contained Steam Source

Kettle shall have a gas-heated (natural, butane, propane) self-contained steam source to provide kettle temperatures of 150 to approximately 295°F. Unit shall be factory charged with chemically-pure water and rust inhibitors to ensure long life and minimum maintenance.

### Controls

Controls shall include a thermostat, pressure gauge, safety valve, pressure limit control, water sight glass, low water cut off, a gas regulator valve and electronic ignition module. Power ON switch, Power ON indicator light, LOW

Model DH-40 shown with optional No. 51 cover



WATER indicator light, and HEATING light are mounted on the kettle support side console. Gas supply shall shut off automatically when unit is tilted.

### Performance Features

Patented fin tube burner assembly delivers 62-65% efficient combustion, depending on size, 20 Gallon Model has 72,000 BTU/HR firing rate with 44,140 BTU/HR into the product; 40 Gallon Model has 100,000 BTU/HR firing rate with 65,000 BTU/HR into the product, and 60 Gallon Model has 150,000 BTU/HR firing rate with 93,000 BTU/HR into the product.

Electronic ignition to standing pilot is standard on all models. Unit shall be thermostatically controlled to automatically shut off when desired temperature is reached and turn on when product temperature drops below setting.

### Installation

Specify natural, propane, butane, or specific propane/butane mixture. Unit requires 1/2" IPS gas line connection and 115 volt electrical connection. No remote steam source required.

### Options

- 2" tangent draw-off valve

### Accessories

- Basket inserts (TRI-BC)
- Lift-off cover (#31)
- Hinged cover kit
- Pan carrier
- Kettle brush kit
- Double and single pantry faucets

### Related Products

- Floor mounted cooker/mixers

### Origin of Manufacture

Kettle shall be designed and manufactured in the United States.

**Stainless Steel  
2/3 Steam Jacketed  
Kettle**

**Floor Mounted  
Tilting  
Self-Contained  
Gas Heated  
20, 40 or 60-  
Gallon Capacity**

### Short Form

Groen Model DH (specify gallons), self-contained, gas heated (specify natural, propane, butane, or mixture) tilting, steam jacketed kettle per Bulletin 144242. All stainless steel construction with reinforced bar rim, butterfly shaped pouring lip and smooth action mechanical tilt. Patented fin tube burner assembly is 62-65% efficient, with electronic ignition standard. NSF listed, A.S.M.E. code constructed for 50 PSI and A.G.A. design certified (Natural & Propane gas only). Requires 1/2" IPS gas line and 115 volt electric service. Made in USA.



### Applications

Meat Dishes  
Vegetables  
Soups  
Sauces  
Pasta  
Rice  
Pie Fillings  
Gravies  
Poultry  
Seafood

TABLE OF DIMENSIONS						
CAPACITY (GALLONS/LITRES)						
20 GAL / 76 LITRES		40 GAL / 152 LITRES		60 GAL / 228 LITRES		
INCHES	MM	INCHES	MM	INCHES	MM	INCHES
A	19 7/16	25 3/4	654	30	762	
B	35	47	1194	47	1194	
C	25 3/4	29 1/2	749	30 7/8	784	
D	31	26 1/2	673	35 1/2	902	
E	32 3/4	832	34 5/8	879	42 7/8	1089
F	18	457	18 1/4	463	19	483
G	39 3/8	1000	43 1/8	1095	46 1/4	1175
H	26	660	28	711	28	711
J	15 5/8	397	13 3/4	349	12 3/8	314
K	27	686	29 1/4	743	35	889
L	30 1/4	768	31	787	31 3/4	806
M	51	1295	60 1/2	1537	61 1/2	1562
N	37 1/4	946	36 1/8	918	43 1/8	1095
P	2	51	5 7/16	138	7 1/2	191

INCOMING GAS PRESSURE TABLE		
TYPE OF GAS	MIN. SUPPLY GAS PRESSURE	MAX. SUPPLY GAS PRESSURE
NATURAL	4.5 W.C.	14.0 W.C.
PROPANE	11.0 W.C.	14 W.C.

FIRING RATE (BTU/HR) FOR BOTH NATURAL AND LP	
DH/20	72,000
DH/1-40	100,000
DH/60	150,000

OPERATING GAS PRESSURE	
NATURAL	PROPANE
3.5W.C.	10.0W.C.

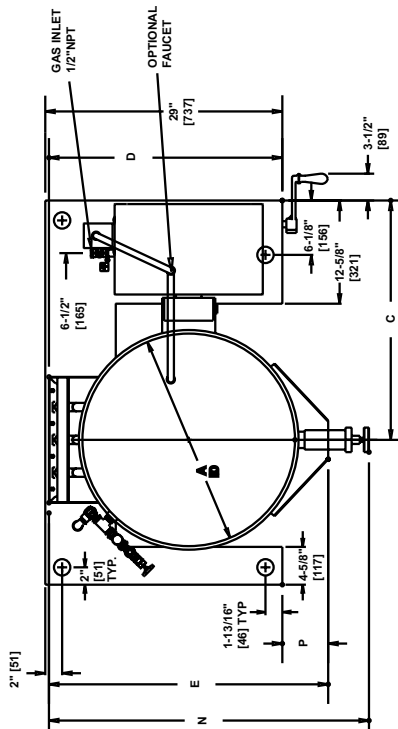

TOP VIEW

- NOTES:**  
 OPTIONAL EXTRA COST FEATURES:  
 1. 2" TANGENT SANITARY DRAW-OFF  
 2. LIFTOFF COVER MODEL #31 FOR DH-20 & DH/1-40 KETTLES.  
 3. HINGED COVER MODEL #61 FOR DH/1-40 & DH-60 KETTLES.  
 4. FAUCET WITH SWING SPOUT  
 5. DIMENSIONS IN BRACKETS [ ] ARE MM

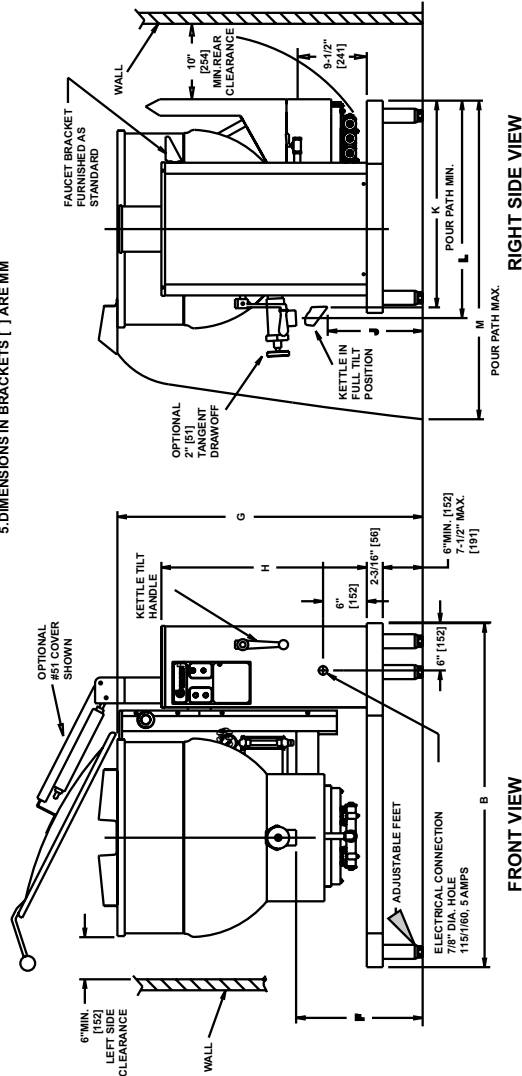

RIGHT SIDE VIEW

FRONT VIEW

