



Floor Kettles model AH/1

Description

Kettle shall be a Groen Model AH/1 (specify 20, 40, 60, 80 or 100 gallons) stainless steel, self-contained, steam jacketed kettle operating from gas heated steam source contained within unit per Bulletin 141047 as follows:

Construction

Kettle proper shall be of type 304 stainless steel, with solid one-piece construction. All exposed surfaces shall be stainless steel. All controls shall be contained within front control enclosure.

Kettle body is sheathed in stainless steel and insulated with fiber bat insulation. Unit provided with three adjustable legs for leveling. Faucet mounting bracket is standard.

Finish

Interior of kettle shall be polished to a 180 emery grit finish. Exterior shall be finished to a uniform #4 satin finish ensuring maximum ease in cleaning and maintaining appearance.

ASME Code, CSA (Formerly AGA) Design Certified, CRN Registered

Unit shall be ASME shop inspected, stamped and registered with the National Board for operation up to a maximum working pressure of 30 PSI. Unit shall be Design Certified by the Canadian Standard Association. Unit shall be registered in Canada with a CRN number.

Sanitation

Unit shall be designed and manufactured to meet NSF requirements and be NSF listed.

Drawoff Valve

Unit shall have a 2" sanitary tangent drawoff which is made of 316 stainless steel. Valve has durable insulated handle, rubber compression sealing disk and is easy to disassemble without tools. The drain outlet shall be equipped with a removable 1/4" perforated stainless steel strainer.

Cover

Cover furnished on 20 gallon units shall be hinged, dome one-piece unit. Units of 40 to 100 gallon capacity shall be furnished with No. 51 counterbalanced actuator designed to maintain the cover in an open or closed position.

Controls

All controls shall be contained in a stainless steel enclosure. Controls include a regulating thermostat, pressure gauge, power-ON switch, power-ON indicator light, heat indicator light, low water indicator light, water sight gauge, pressure safety valve, pressure limit control, low water cut off, a gas regulator valve and electronic ignition module; with all operating controls front mounted.

Performance/Features

Unit shall be thermostatically controlled to automatically shut off when desired temperature is reached and turn on when product temperature drops below desired setting. Electronic ignition to standing pilot is standard on all models. Outer sheathing and fiber insulation retain heat and keep kettle exterior cool to the touch.

Model AH/1 shown



Self-Contained Steam Source

Kettle shall have a gas-heated, self-contained steam source to provide kettle temperatures of 150 to 270°F. Unit shall be factory charged with water and rust inhibitor to ensure long life and minimum maintenance.

Installation

Unit requires 1/2" NPT gas line connection and 115 volt electric supply to operate controls. No remote steam source required.

Options/Accessories

- Basket inserts (TRI-BC)
- Water fill faucets
- 3" tangent draw-off valve
- 1/8" perforated or solid disc strainer
- 316 stainless steel interior
- Other supply voltages
- Kettle brush kit

Origin of manufacture

Kettle shall be designed and manufactured in the United States.



**Stainless Steel
Steam Jacketed
Kettle**

**Floor Mounted
Stationary
Self-Contained
Gas Heated
20, 40, 60, 80 or 100-
Gallon Capacity**

Short Form

Groen Model AH/1 (Specify gallons), self contained Natural/Propane (specify) gas heated stainless steel steam jacketed kettle per Bulletin 141047, complete with 2" tangent draw-off valve, (3" optional) and No. 41 cover. 40 to 100 gallon units furnished with No. 51 spring assisted cover. Steam jacket is insulated and ASME code constructed for maximum working pressure of 30 PSI. Unit is thermostatically controlled, with electronic ignition standard. CAS design certified and NSF listed. Requires 1/2" gas supply and 115 Volt electric service. Made in the USA.

Applications

Meat Dishes
Vegetables
Soups
Sauces
Pasta
Rice
Pie Fillings
Gravies
Poultry
Seafood

TABLE OF DIMENSIONS

CAP.	20 GAL.		40 GAL.		60 GAL.		80 GAL.		100 GAL.	
	7.5	150	150	225	225	300	300	378	378	456
DIM.	INCH	MM	INCH	MM	INCH	MM	INCH	MM	INCH	MM
A	20	508	26	660	30	762	31 3/4	806	31 3/4	806
B	26 1/8	664	32 3/8	822	36	914	37 3/4	959	37 3/4	959
C	24	610	30 3/8	772	33 1/2	851	35 3/4	908	35 3/4	908
D	26 1/2	673	29 1/8	740	29 1/2	749	30 1/2	775	30 1/2	775
E	50 3/4	1289	56 1/4	1429	58 1/4	1480	--	--	61-1/4	1556
F	39 1/2	1003	43 1/4	1099	46 1/4	1175	48	1219	48	1219
G	33 1/2	851	33	838	38 1/8	968	43 1/4	1099	43 1/4	1099
H	40	1016	41	1041	48 7/8	1241	56 1/2	1435	62 1/2	1588
J	9	229	9	229	11	279	11 1/2	292	11 1/2	292
K	18 1/2	470	16 3/4	425	21 3/8	543	24 1/4	616	24 1/4	616
L	6 3/4	171	6	152	6 1/8	156	8 1/2	216	8 1/2	216
M	73	1854	74 3/4	1899	76 5/8	1946	91 1/2	2324	97 1/2	2477
N	6	152	6	152	7	178	7	178	7	178
P	17 1/2	445	21 3/8	543	24 5/8	625	29 1/2	749	35 1/4	895
R	17 1/2	445	21	533	16 5/8	422	24 1/2	622	24 1/2	622
S	12	305	12	305	12	305	12	305	12	305

SERVICE CONNECTIONS AND NOTES:

1. ELECTRICAL CONNECTION: 115V, 1 PH, 60 HZ, 2 AMPS
2. GAS CONNECTION: 1/2 NPT.
3. MINIMUM CLEARANCE REQUIRED.
4. MODEL #41 HINGED COVER IS STD. ON 20 GAL. SIZE.
5. MODEL #51 POWER AID COVER (SHOWN) STD. ON 40, 60, 80 & 100 GAL. SIZES.
6. SINGLE OR DOUBLE PANTRY FAUCETS ARE OPTIONAL.
7. 3" TANGENT DRAWOFF IS OPTIONAL.
8. DIMENSIONS IN BRACKETS () ARE MM.

SCALE: .04 = 1
DO NOT SCALE DRAWING

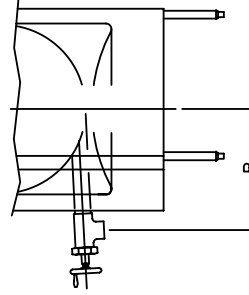

OPTIONAL 3" TANGENT DRAWOFF

GAS SUPPLY SPECIFICATIONS

MODEL	AH/1-20	AH/1-40	AH/1-60	AH/1-80	AH/1-100
NATURAL GAS BTU/HR	85,000	100,000	145,000	145,000	145,000
PROPANE GAS BTU/HR	85,000	85,000	145,000	145,000	145,000

RECOMMENDED INCOMING GAS FEED RATE INCHES WATER COLUMN

NATURAL GAS	4.5" W.C. MIN. 14" W.C. MAX.
PROPANE GAS	11" W.C. MIN. 14" W.C. MAX.

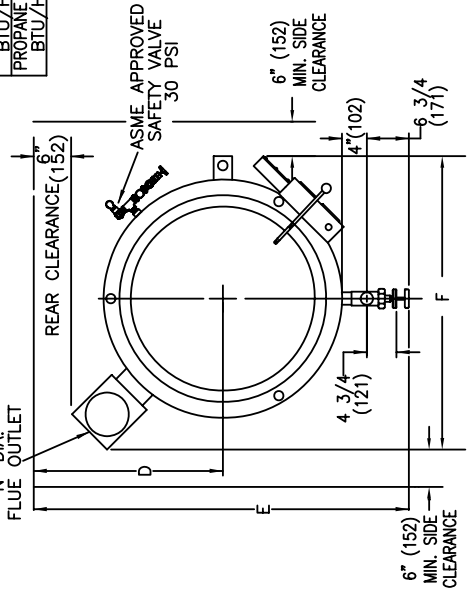
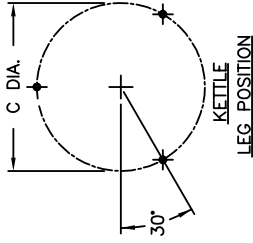

TOP VIEW

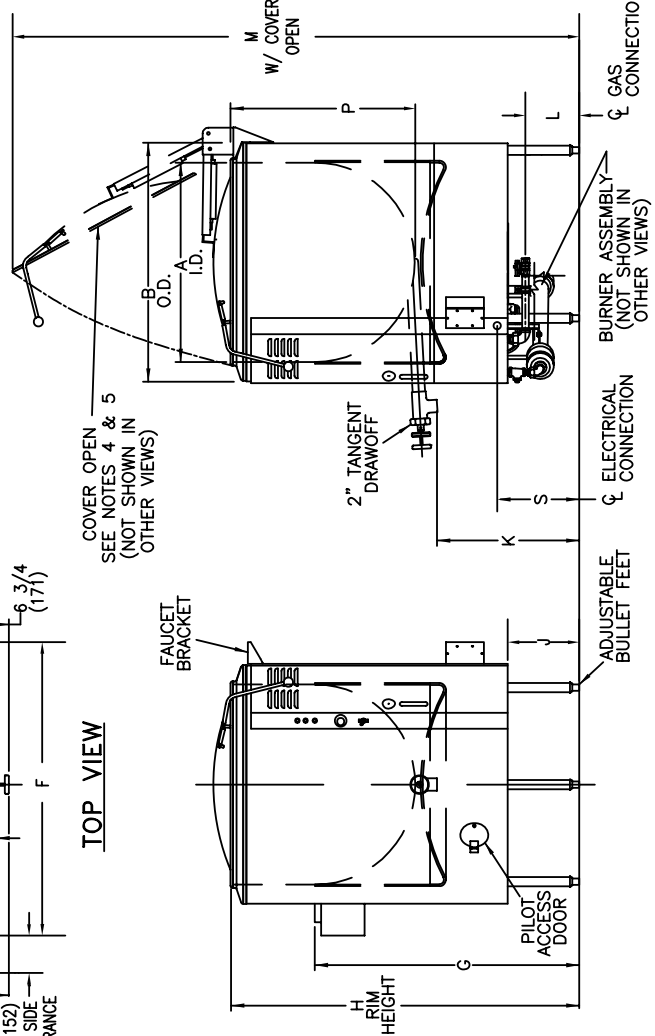

RIGHT SIDE VIEW

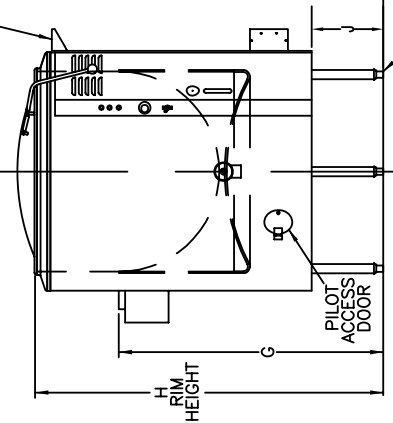

FRONT VIEW

