

SmartSteam100 Boilerless Steamer model (2)SSB-5GF

Description

Steamer shall be a Groen Model (2)SSB-5GF double-stacked SmartSteam100™ stainless steel, boilerless, convection steamer. Each steamer shall have a self-contained atmospheric 62,000 BTU/hr gas steam generating reservoir.

Construction

Steamer cavity, cabinet and stand shall be all stainless steel construction, with removable right and left-side panels, providing access to internal components. Steamer shall have no side vents for increased water/spray resistance.

Steamer doors shall be all stainless steel with a strong continuous hinge and field-reversible for left or right swing. Doors shall be insulated and provided with a one-piece, replaceable seal. Easy-open door handles and latches shall provide positive lock and seal when doors are pushed or slammed shut.

A hidden magnetic door switch shall cut power to blower fan and shut down power to the steam generating reservoir when the door is opened. Pan support racks shall be stainless steel and removable for easy cleaning. A stainless steel condensate collection tray shall be positioned under each cavity door.

Finish

Cabinet exterior, including door, shall be a No. 4 uniform finish. Cavity interior shall be polished stainless steel. Control panel face plate shall be smudge-resistant polyester film, ensuring maximum ease in cleaning and maintenance of an attractive appearance.

CSA Listing

Steamer shall be CSA (formerly CGA) design certified.

Sanitation

Steamer shall be designed and manufactured to meet NSF requirements and all known health codes. Steamer shall be NSF listed.

Controls

Steamer controls shall include an on-off rocker switch; electronic timer, with continuous steam, timed steam and stop buttons; READY light which indicates when cavity is warm and ready for steaming.

Performance Features

Steamer cavities shall have powerful, side-mounted blowers to increase steam velocity and provide efficient steam distribution throughout the cavity and between loaded pans. Steam generators shall deliver 12,400 BTU/hr of power input per 2-1/2" deep steam pan. Steamer shall have a steam lid positioned over each steam generating reservoir to ensure that adding/removing food does not lower the cavity or water temperature.

Heat up time to READY shall typically be 15 minutes or less. Cavity is kept warm and ready for instant steam between loads. No cavity warm up required after READY light comes on.

Model (2)SSB-5EF shown



Atmospheric Steam Generating Reservoir

Each steamer shall have a gas-heated steam generating reservoir to provide atmospheric steam to the cavity at a temperature of approximately 212° F. The high-efficiency steam generating reservoirs shall have water level sensors. Gas heaters shall have infrared burners with a firing rate of 62,000 BTU/hr.

Acidic products and other commercial chemicals shall not be used to clean the steamer. A daily wipe down of the steamer cavity, steam lid and floats is sufficient to maintain optimal operation of the steamer. However, Groen Descaler or approved equal may be required.

Pan Capacity

Pan Size	Per Cavity	Total
12 x 20 x 1"	10	20
12 x 20 x 2 1/2"	5	10
12 x 20 x 4"	3	6

Installation

Steamer shall require natural or propane (specify) gas service via a 1/2" NPT gas supply line, or approved equivalent. Steamer shall be connected to a 3/4" NH cold water supply line and a 2-1/2" free venting drain. Steamer shall require two 115 Volt, single-phase electrical service connections.

Water Supply Requirements

Steamer must be connected to an on-site water supply. Water supply at 30 to 60 PSIG with flow at .75 - 1.5 GPM per cavity.

Options/Accessories

- Flanged Foot Kit (for support stand)
- Caster Kit (for support stand)
- High Altitude Kit (above 2000', specify)
- Heat Shield Kits

Origin of Manufacture

Steamer shall be designed and manufactured in the U.S.A.

10-Pan Boilerless Convection Steamer (5 pans per cavity)

Double-Stacked, Stand-Mounted, Stainless Steel, Self-Contained, Gas Heated

Short Form (2)SSB-5GF

Steamer shall be a Groen double-stacked SmartSteam100™ Boilerless Convection Steamer Model (2)SSB-5GF. Each steamer cavity shall have a self-contained, atmospheric, gas-heated steam generating reservoir. Construction shall be all stainless steel. Cavities shall have powerful side-mounted blowers to circulate steam. Standard operating controls shall include: an on-off rocker switch; electronic timer, with continuous steam, timed steam and stop buttons; READY light. Doors shall be field-reversible and shall be equipped with an easy-open latch and hidden magnetic door switch. The atmospheric steam generating reservoirs shall not require a pressure gauges or switches; shall have an automatic drain and shall have an infrared burner with 62,000 BTU/hr of heating capacity per cavity. Steamer shall come up to READY in 15 minutes from a cold start and shall provide warm cavity, instant steam capability. Gas, electric, water and drain connections shall conform to instructions provided on the back side of this sheet. CSA design-certified and NSF listed. Made in the USA.



Applications

- Pasta
- Rice
- Vegetables (Fresh & Frozen)
- Seafood (Fresh & Frozen)
- Poultry
- Potatoes
- Eggs
- Meats
- Reheat Cook-Chill & Prepared Foods

SERVICE CONNECTIONS & NOTES:

- ① DRAIN CONNECTION: 2-1/2" [64] TUBE (DRAIN FREE VENTING). DO NOT CONNECT DIRECTLY TO DRAIN. ALLOW A 2" AIR GAP
- ② GAS CONNECTION: 1/2" FPT GAS SYSTEM MUST DELIVER 124,000 BTU'S MINIMUM AT UNIT.
- ③ WATER SUPPLY: 3/4" MALE HOSE CONNECTION 30 TO 60 PSIG WITH A FLOW RATE OF 1.50-3.00 GPM. PRESSURE REGULATION IS REQ'D FOR WATER PRESSURE OVER 60 PSI. DO NOT USE TREATED WATER.
- ④ ELECTRICAL CONNECTION: 120VAC, 60Hz, 15AMP CONDUIT SIZE: 13/16" HOLE
- ⑤ MINIMUM REAR AND SIDE CLEARANCES: EACH = 2" [50.8] REAR = 6" [152.4]
- ⑥ DIMENSIONS IN BRACKETS [] ARE MM.
- ⑦ IF THE FLOOR DRAIN ONLY SERVICES THIS STEAMER, THEN THE DRAIN MAY BE LOCATED WITHIN THE STEAM FREE ZONE. STEAM FREE ZONE MUST BE OBSERVED IF OTHER APPLIANCES CAUSE STEAM AT THE FLOOR DRAIN.
- ⑧ DO NOT INSTALL STEAMER DIRECTLY ABOVE STEAM VENTING FLOOR DRAINS
- ⑨ STEAM EXHAUST

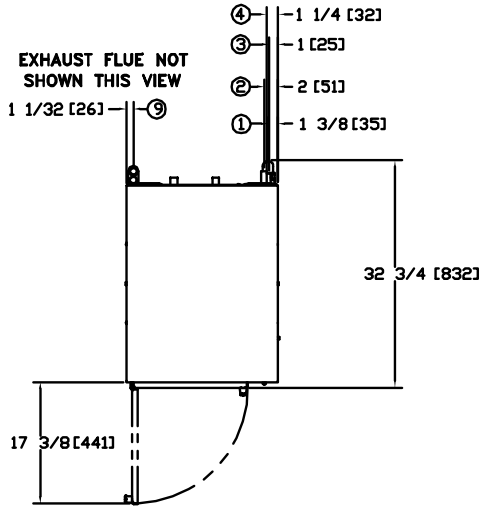

	NATURAL GAS	PROPANE GAS
RECOMMENDED INCOMING GAS FEED RATE	5" WC (1.2 KPa) MIN. 14" WC (3.5 KPa) MAX.	12" WC (3 KPa) MIN. 14" WC (3.5 KPa) MAX.
GAS OPERATING PRESSURE	4.25" W.C.	10.5" W.C.
MAX. INPUT BTU/HR	124,000	124,000

STEAM FREE ZONE
SEE NOTES

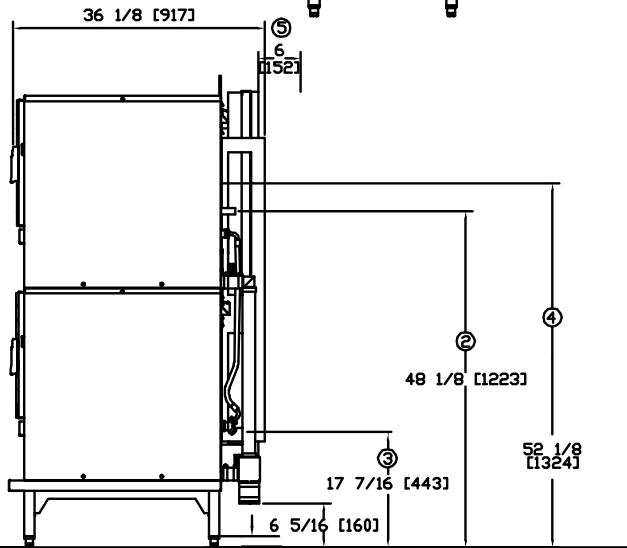
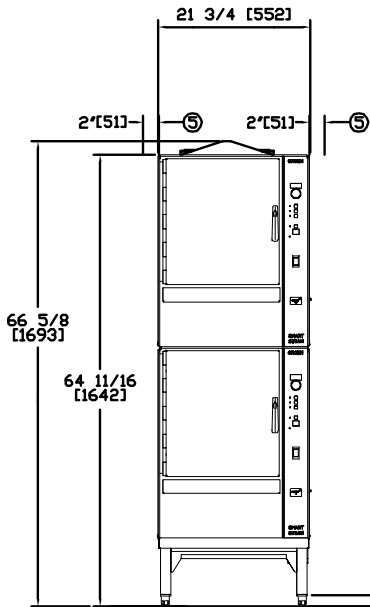
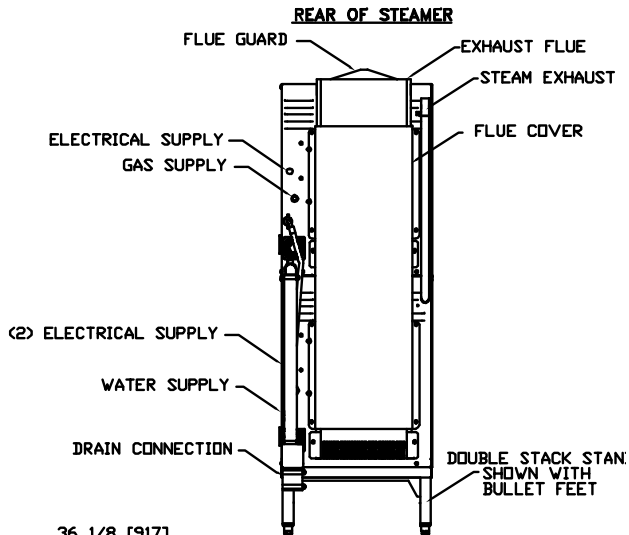
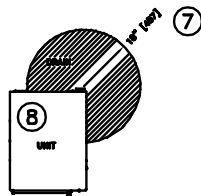

FRONT VIEW

SIDE VIEW

1 1/2 [38] MINIMUM
2 5/8 [87] MAXIMUM

5" [127] WITH CASTERS (NOT SHOWN)

