

## SmartSteam100 Boilerless Steamer model (2)SSB-5EF

### Description

Steamer shall be a Groen Model (2)SSB-5EF double-stacked SmartSteam100™ stainless steel, boilerless, convection steamer. Each steamer cavity shall have a self-contained atmospheric 12 KW electric steam generating reservoir.

### Construction

Steamer cavity and cabinet shall be all stainless steel construction, with removable right and left-side panels, providing access to internal components. Steamer shall have no side vents for increased water/spray resistance.

Steamer doors shall be all stainless steel with a strong continuous hinge and field-reversible for left or right swing. Doors shall be insulated and provided with a one-piece, replaceable seal. Easy-open door handles and latches shall provide positive lock and seal when doors are pushed or slammed shut.

A hidden magnetic door switch shall cut power to blower fan and shut down power to the steam generating reservoir when the door is opened. Pan support racks shall be stainless steel and removable for easy cleaning. A stainless steel condensate collection tray shall be positioned under each cavity door.

### Finish

Cabinet exterior, including door, shall be a No. 4 uniform finish. Cavity interior shall be polished stainless steel. Control panel face plate shall be smudge-resistant polyester film, ensuring maximum ease in cleaning and maintenance of an attractive appearance.

### UL Listing

Steamer shall be UL and cUL listed.

### Sanitation

Steamer shall be designed and manufactured to meet NSF requirements and all known health codes. Steamer shall be NSF listed.

### Controls

Steamer controls shall include an on-off rocker switch; electronic timer, with continuous steam, timed steam and stop buttons; READY light which indicates when cavity is warm and ready for steaming.

### Performance Features

Each steamer cavity shall have a powerful, side-mounted blower to increase steam velocity and provide efficient steam distribution throughout the cavity and between loaded pans. Steam generators shall deliver 2.4 KW of electric power input per 2-1/2" deep steam pan. Steamer shall have a steam lid positioned over each steam generating reservoir to ensure that adding/removing food does not lower the cavity or water temperature.

Heat up time to READY shall typically be 15 minutes or less. Cavity is kept warm and ready for instant steam between loads. No cavity warm up required after READY light comes on.

### Atmospheric Steam Generating Reservoir

Each steamer shall have an electric-heated steam gener-

Model (2)SSB-5EF shown



ating reservoir to provide atmospheric steam to the cavity at a temperature of approximately 212° F. The high-efficiency steam generating reservoirs shall have water level sensors. Electric heating elements shall not be immersed in water (dry) and replaceable from the rear.

Acidic products and other commercial chemicals shall not be used to clean the steamer. A daily wipe down of the steamer cavity, steam lid and floats is sufficient to maintain optimal operation of the steamer. However, Groen Descaler or approved equal may be required.

### Pan Capacity

Pan Size	Per Cavity	Total
12 x 20 x 1"	10	20
12 x 20 x 2 1/2"	5	10
12 x 20 x 4"	3	6

### Installation

Steamer shall require two 208, 240 or 480 Volt, 3-phase electrical service connections. Single phase shall be available for 208 and 240 Volt operation. Steamer shall be connected to a 3/4" NH cold water supply line and a 2-1/2" free venting drain.

### Water Supply Requirements

Steamer must be connected to an on-site water supply. Water supply at 30 to 60 PSIG with flow at .75 - 1.5 GPM per cavity.

### Options/Accessories

- Flanged Foot Kit (for support stand)
- Caster Kit (for support stand)
- Heat Shield Kits

### Origin of Manufacture

Steamer shall be designed and manufactured in the U.S.A.

**10-Pan Boilerless Convection Steamer (5 pans per cavity)**

**Double-Stacked, Stand-Mounted, Stainless Steel, Self-Contained, Electric Heated**

### Short Form (2)SSB-5EF

Steamer shall be a Groen double-stacked SmartSteam100™ Boilerless Convection Steamer Model (2)SSB-5EF. Each steamer cavity shall have a self-contained, atmospheric, electric-heated steam generating reservoir. Construction shall be all stainless steel. Cavities shall have powerful side-mounted blowers to circulate steam. Standard operating controls shall include: an on-off rocker switch; electronic timer, with continuous steam, timed steam and stop buttons; READY light. Doors shall be field-reversible and shall be equipped with an easy-open latch and hidden magnetic door switch. The atmospheric steam generating reservoirs shall not require a pressure gauges or switches; shall have an automatic drain and shall have 12KW of dry element heating capacity per cavity. Steamer shall come up to READY in 15 minutes from a cold start and shall provide warm cavity, instant steam capability. Electric, water and drain connections shall conform to instructions provided on the back side of this sheet. UL/cUL and NSF listed. Made in the USA.



### Applications

- Pasta
- Rice
- Vegetables (Fresh & Frozen)
- Seafood (Fresh & Frozen)
- Poultry
- Potatoes
- Eggs
- Meats
- Reheat Cook-Chill & Prepared Foods

**SERVICE CONNECTIONS & NOTES:**

- ① DRAIN CONNECTION: 2-1/2" [64] TUBE (DRAIN FREE VENTING). DO NOT CONNECT DIRECTLY TO DRAIN. ALLOW A 2" AIR GAP
- ② WATER SUPPLY: 3/4" MALE HOSE CONNECTION. 30 TO 60 PSIG WITH A FLOW RATE OF 1.50-3.00 GPM. PRESSURE REGULATOR IS REQ'D FOR WATER PRESSURE OVER 60 PSI. DO NOT USE TREATED WATER.
- ③ ELECTRICAL CONNECTION: SEE CHART  
CONDUIT HOLE SIZE: 13/16" HOLE
- ④ MINIMUM REAR AND SIDE CLEARANCES:  
EACH SIDE = 2" [50.8]  
REAR = 6" [152.4]
- ⑤ DIMENSIONS IN BRACKETS [ ] ARE MM.
- ⑥ IF THE FLOOR DRAIN ONLY SERVICES THIS STEAMER, THEN THE DRAIN MAY BE LOCATED WITHIN THE STEAM FREE ZONE. STEAM FREE ZONE MUST BE OBSERVED IF OTHER APPLIANCES CAUSE STEAM AT THE FLOOR DRAIN.
- ⑦ DO NOT INSTALL STEAMER DIRECTLY ABOVE STEAM VENTING FLOOR DRAINS
- ⑧ STEAM EXHAUST

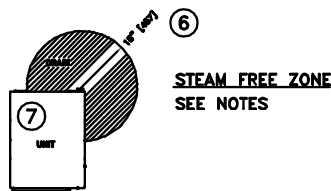
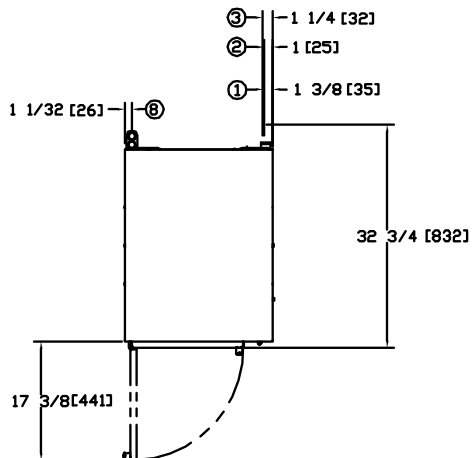

ELECTRICAL REQUIREMENTS PER COMPARTMENT				
VOLTAGE	PHASE	AMPS	MAX. KW	
208	1	58	12	
	3	34	12	
240	1	50	12	
	3	29	12	
480	3	15	12	
ALL UNITS 60Hz				

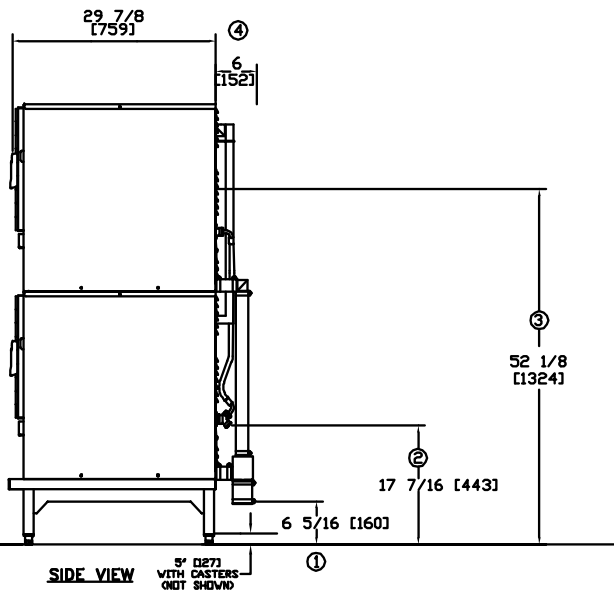
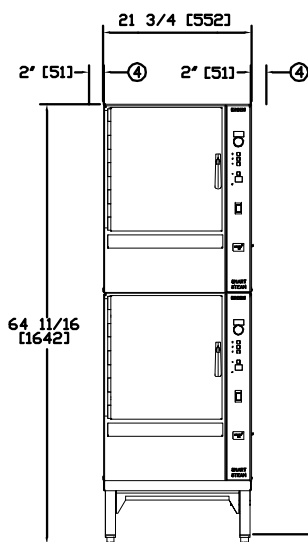
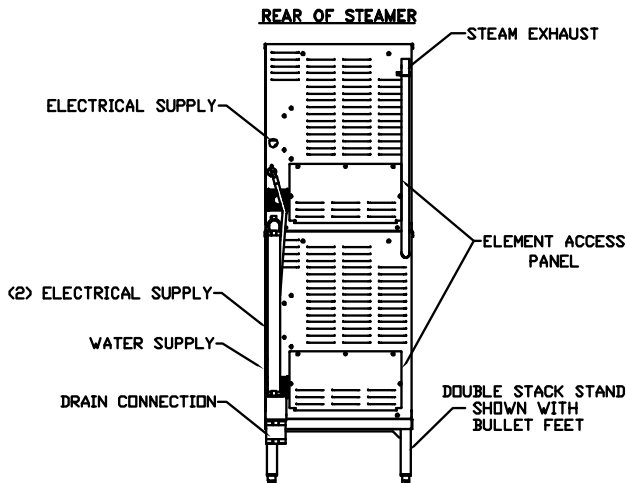

FRONT VIEW

SIDE VIEW

1 1/2 [38] MINIMUM  
2 5/8 [67] MAXIMUM

5" [127] WITH CASTERS  
OUT SHELVING

