



Project _____

Item # _____

Quantity _____



SP62P

SP62P 60 Quart Pizza Mixer

NOW with electronic timer

Built into each mixer is the quality of design and workmanship synonymous with Globe.

Model

- SP62P - 60 Quart Pizza Mixer



GLOBE FOOD EQUIPMENT COMPANY

60 Quart Pizza Mixer

Quality Construction

- Rigid cast iron body
- High torque direct gear drive transmission
- Oil bath transmission
- Heat-treated hardened steel alloy gears and shafts
- Stainless steel bowl guard with built in ingredient chute
- Industry standard #12 attachment hub
- Non-slip rubber feet
- NSF approved enamel gray paint

Standard Features

- Powerful 3 HP custom built motor
- Two fixed speeds
- Capacity: up to 50 lbs. of flour (75 lb. batch size)
- Front mounted digital timer and controls
- Safety interlocked bowl guard and bowl lift
- Thermal overload protection
- Power bowl lift
- Automatic safety shut off provides superior motor and transmission protection

Standard Accessories

- 60 quart stainless steel bowl
- Spiral dough hook (aluminum)
- Bowl truck

Optional Attachments/Accessories

- Slicer/shredder/grater for #12 hub
- Meat grinder for #12 hub
- Correctional Package

Warranty

- Two-years parts and one-year labor

Approved By: _____

Date: _____

SP62P



GLOBE FOOD EQUIPMENT COMPANY

www.globeslicers.com

2153 Dryden Rd.
Dayton, OH 45439
Phone: 937-299-5493
Phone: 800-347-5423
Fax: 937-299-4147



60 Quart Pizza Mixer

SP62P

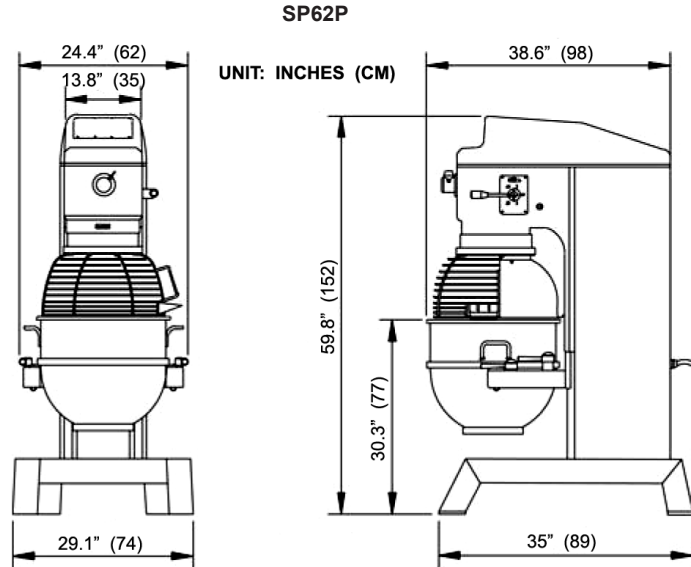

SPECIFICATIONS

Model	Motor	Volts	Amps	Transmission Type	Capacity	Controls	Power Bowl Lift	Agitator Speeds (RPMs)		Attachment Speeds (RPMs)	
								First	Second	First	Second
SP62P (1 Phase)	3 HP	220/60/1	16	Gear	60 qt / 56.8L	Digital, Front mounted Timer & Controls	1/8 HP Motor	72	116	234	410
SP62P (3 Phase)	3 HP	208/60/3	12	Gear	60 qt / 56.8L						

STANDARD FEATURES & ACCESSORIES:

- 60 Quart #304 series stainless steel bowl
- Aluminum spiral dough hook
- Stainless steel bowl guard with built in ingredient chute
- Digital, front mounted timer and controls
- Heavy duty bowl truck
- #12 attachment hub
- Direct drive, fixed speed transmission provides high torque mixing power
- Thermal overload protection (automatic reset)
- NSF approved enamel gray paint
- 6 foot cable, hard wired

OPTIONAL ATTACHMENTS:

- Chopper Plate Sizes Available:
 - CP02-12 1/16" (2mm)
 - CP04-12 5/32" (4mm)
 - CP05-12 3/16" (5mm)
 - CP06-12 1/4" (6mm)
 - CP08-12 5/16" (8mm)
 - CP10-12 3/8" (10mm)
 - CP12-12 1/2" (12mm)
 - CP14-12 9/16" (14mm)
 - CP16-12 5/8" (16mm)
 - CP18-12 11/16" (18mm)
 - CP00-12 Stuffing Plate
- XST12 1/2" stuffing tube (sheep)
- XST34 3/4" stuffing tube (hog)
- XMCA-SS Meat Grinder Assembly (Polished stainless steel cylinder, worm gear, ring, and pan. Includes knife, 3/16" plate, stainless steel pan, and pusher.)
- XXCORR62 Correctional package includes tamper resistant external fasteners.
- XVSGH 9" Slicer/Shredder/Grater Housing Only (no plates included-must select from plates below)
- XASP Adjustable slicing plate
- Shredding/Grating Plates:
 - XSP332* 3/32" (2.3mm)
 - XSP316* 3/16" (4.7mm)
 - XSP14* 1/4" (6.3mm)
 - XSP516* 5/16" (7.9mm)
 - XSP12* 1/2" (12.7mm)
 - XGP* Grating plate
- XPH Plate holder -*only 1 required

DIMENSIONS & SHIPPING INFORMATION

Cartons are reinforced for shipping. The weight and dimensions of this reinforced carton are included below and may vary from shipment to shipment. **This product ships on a pallet.**

Model	Foot Print	Overall Dimensions	Net Weight	Shipping Dimensions	Shipping Weight
SP62P	35" D x 29.1" W (89 cm x 74 cm)	38.6" L x 29.1" W x 59.8" H (98 cm x 74 cm x 152 cm)	980 lbs. (444 kg)	48" W x 48" D x 76" H (122 cm x 122 cm x 193 cm)	1,228 lbs. (556 kg)

Freight Class 85



GLOBE FOOD EQUIPMENT COMPANY

www.globeslicers.com

2153 Dryden Rd.
Dayton, OH 45439
Phone: 937-299-5493
Phone: 800-347-5423
Fax: 937-299-4147