



S684 Sentry Series Electric Restaurant Range

Item: _____
 Quantity: _____
 Project: _____
 Approval: _____
 Date: _____

S684 Sentry Series Electric Restaurant Range

Models:

- S684 SU684 SS684



Model S684

NOTE: Ranges supplied with casters must be installed with an approved restraining device.

Standard Features:

- Stainless steel exterior
- 2 large, full size ovens with complete porcelain interior finish
- Removable, 4 position, oven rack guides with one oven rack per oven
- Electro-mechanical heavy duty oven thermostat, (150°F/66°C - 550°F/288°C)
- 10 tubular heating elements, infinite switch controlled
- Cool touch oven door handle
- 10" (254mm) high stainless steel backguard with slotted black enameled angled cap
- 6" (152mm) high stainless steel adjustable legs
- 6 sealed, high performance elements with over heat protection and 6-heat switch in lieu of tubular elements, CE approved model SU684, or North American Model SS684
- 1 Year limited warranty on parts & labor (USA & Canada only)

Optional Features:

- Convection oven(s), (add suffix -RC for sgl., or -RC2 for dbl.) Each

convection oven comes standard with 3 oven racks

- 5/8" (16mm) thick thermostatically controlled griddle plate available in 12", add suffix 12G, 24" add suffix 24G and 36", add suffix 36G, standard on the right, left optional
- Solid Steel Hot top 1/2" (13mm) thick utilizing front and rear switch controls, available in 12", add suffix 1, 24" add suffix 2, and 36", add suffix 3, standard on the left, right optional (Note: Maximum (3) three hot top sections per range.)
- Additional Oven Rack
- Swivel casters with front brakes
- 17" (432 mm) high stainless steel backguard with slotted black enameled angled cap
- Stainless steel two piece easy to assemble backguard and plate shelf
- Range mounted salamander broiler (Model SER-680). CE Marked range mounted salamander is SUER-680. Specify right or left side, 24" wide high-shelf included.
- Marine equipment - storm rails for pots, oven door latch, drip tray stop and deck fasteners

Specifications:

Electric medium duty range with 2 full-size ovens, all porcelain oven interior, contoured front stainless steel plate rail, 60" (1524mm) wide, with 10 all purpose tubular heating elements. Stainless steel exterior, with stainless steel 10" (254mm) high backguard with slotted black enameled angled cap. Available with optional sealed elements with "over heat protection" - reducing power if element is turned on w/o pan for 8 minutes, hot top(s) and griddle. Available with convection oven base(s).



Note: Only models with prefix "SU" carry the CE Mark



Model	Total Kw Load	Nominal Amps					
		208V/1Ph	208V/3 Ph	240V/1Ph	240V/3 Ph	400 V/3N	415V/3N
S684*	27	127	76	110	66	—	—
SS/SU684**	33	157	97	136	84	60	58
SS/SU684RC2***	34	N/A	100	142	87	60	58
Salamander Broiler****	7	N/A*****	23	29	20	4	4

*(All purpose tubular elements) ** (Sealed -top elements, Model # SS684 in North America) *** Maximum on any 684 series range.
 ****Add when wired to range base (SER/SUER-680) *****Note: For 208V/1phase the salamander cannot be wired into the range.

Exterior Dimensions			Oven Interior Dimensions		
Height	Width	Depth†	Height	Width	Depth
47" (1194mm)	60" (1524mm)	34-1/4" (870mm)	13-1/2" (343mm)	26-1/4" (667mm)	22" (559mm)

† With Front Rail Note: Shipping Cubic Feet is 84.5.

Ratings:

Tubular Elements - Small 6-1/2" (165mm) - 1250 Watts. Large 8-1/2" (216mm) - 2100 Watts
 Sealed Elements - Small 7" (180mm) - 2000 Watts. Large 8-5/8" (220mm) - 2600 Watts
 Hot Plate - (per 12"/305mm section) - Front and Rear sections each 1675 Watts, (3350 Watts total)
 Griddle - (per 12"/305mm section) - 3350 Watts
 Standard Oven - 4.85 kW
 Convection Oven - 5.0 kW (plus 0.5kW fan motor, for 5.5kW total)

NOTE: Many local codes exist, and it is the responsibility of the Owner and the Installer to comply with those codes.

Installation Clearances:	Side	Back
Range w/o Salamander	3" (76mm)	2" (51mm)
Range w/ Salamander	7" (178mm)	2" (51mm)
Hot Plate	10" (254mm)	—

NOTE: For ranges with convection oven(s), (models with suffix `RC' or `RC2'), air circulation is required for proper operation of fan motors. These models must not be dais mounted or installed without legs.

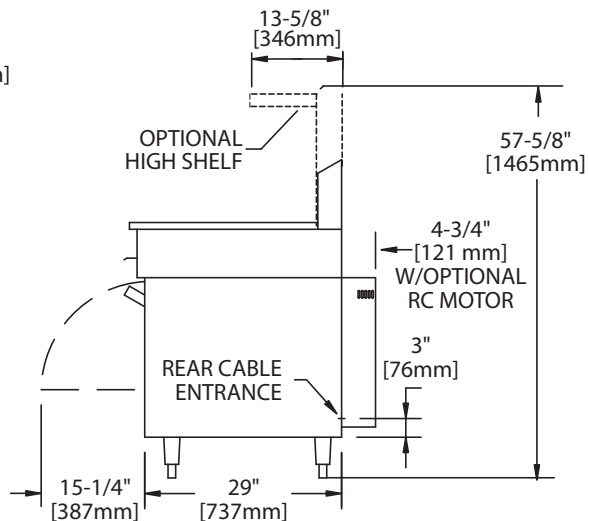
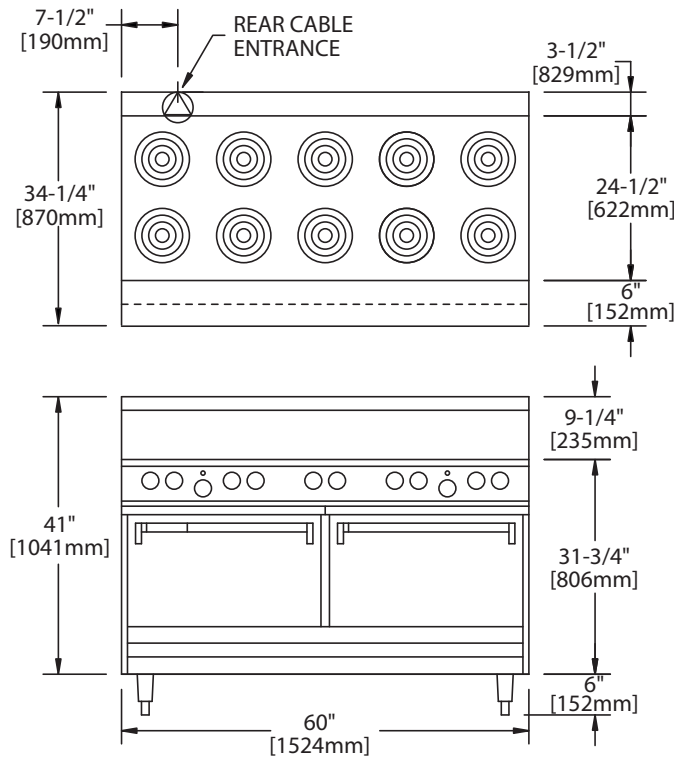

Form# S684 (07/29/11)