



Item: _____
 Quantity: _____
 Project: _____
 Approval: _____
 Date: _____

Models:

- MCO-GS-10-S MCO-GS-20-S MCO-GD-10-S MCO-GD-20-S



Model MCO-GS-10-S

Note: Ovens supplied with casters must be installed with an approved restraining device.

Standard Features:

- Master 200 Solid State Control with 150° F (66°C) to 500°F (250°C) temperature range and electromechanical timer
- Electronic spark ignition, including automatic pilot system with 100% safety shut off
- 2-speed fan control (high & low) w/3/4HP fan motor
- Total of 60,000 BTU (17.6 kW) loading per oven cavity
- Natural or propane gas
- Stainless steel front, sides, top, and legs
- 60/40 dependent door design with double pane thermal window in both doors and interior lighting
- Full Length, stainless steel positive door closure
- Patented "Safety Door System"
- Porcelain enameled oven interior with coved corners
- 24" cooking cavity height w/6 chrome plated oven racks on 13-position rack guides
- Double deck models available, suffix -20-S
- Deep depth models available prefix MCO-GD

- 1 year limited parts & labor warranty (USA & Canada only)
- 5 year limited door warranty, excluding window (USA & Canada only)

Optional Features:

- 80,000 BTU (23.4kW) burner package (natural gas)
- Stainless steel solid door or doors (specify) – No Charge
- Stainless steel oven interior
- Extra oven racks
- Swivel casters, (4) w/front brakes
- 4 Low profile casters, w/front brakes (double ovens only)
- Stainless steel open base with rack guides and shelf
- Canopy draft diverter (stainless steel)
- Direct connect vent
- Back enclosure (stainless steel)
- 3/4" gas flex hose & quick disconnect
- 208 or 240 volt, single phase motor (please specify)
- 50 cycle components
- Maximum security package available contact factory for details

Specifications:

Garland Master Full-Size Standard Depth, prefix MCO-GS or Deep Depth, prefix MCO-GD, gas convection oven. 60,000 BTU (17.6 kW)/cavity, 3/4 HP fan motor with two speed fan control. Electronic spark ignition. Natural or propane gas. Master 200 solid state control with electromechanical timer. Porcelain enameled oven interior with coved corners, Six (6) oven racks and 13-position rack guides. All model interiors are 29" (736mm) W by 24" (610mm) H, depth is 24" (610mm) for standard depth and 28" (711mm) for deep depth. Stainless steel front, sides, top, and legs. 60/40 dependent door design with double pane thermal window in both doors and interior lighting. Models with suffix -20-S are

double deck units. Specify voltage if other than 115 volt, 60 Hz, 1 phase. UL, CUL Gas-Fired and NSF Listed.



SINGLE-DECK MODELS	INT. DIMENSIONS: In mm			EXT. DIMENSIONS: In mm			SHIP WT.	SHIP DIM.
	W	H	D	W	H*	D	lbs/kg	cubic Ft.
Standard Depth	29 (736)	24 (610)	24 (610)	38 (965)	57-1/2 (1461)	41-1/4(1048)	515/230	58.5
Deep Depth	29 (736)	24 (610)	28 (711)	38 (965)	57-1/2 (1461)	44-1/2(1130)	545/245	58.5

DOUBLE-DECK MODELS	INT. DIMENSIONS: In mm			EXT. DIMENSIONS In mm			SHIP WT.	SHIP DIM.
	W	H	D	W	H*	D	2@lbs/kg	Cubic Ft.
Standard Depth	29 (736)	24 (610)	24 (610)	38 (965)	70-1/2 (1791)	41-1/4(1048)	1030/465	117
Deep Depth	29 (736)	24 (610)	28 (711)	38 (965)	70-1/2 (1791)	44-1/2(1130)	1090/490	117

*Height with or without standard casters. Height with low profile casters (double deck) is 68-1/2" (1740mm).

MODELS	INPUT RATINGS, NAT & PRO			ELECTRICAL SPECIFICATIONS	
	BTU/hr	kW Eqiv.	Gas inlet	120V/1Ph.	240V/1Ph.
Single Deck	60,000	17.6	(1)@3/4" NPT	(1)@9.8A	(1)@5.2A
Double Deck	120,000	35.2	(1)@1" NPT	(2)@9.8A	(2)@5.2A

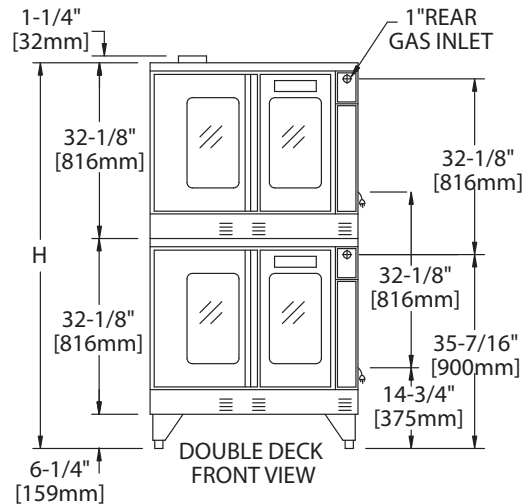
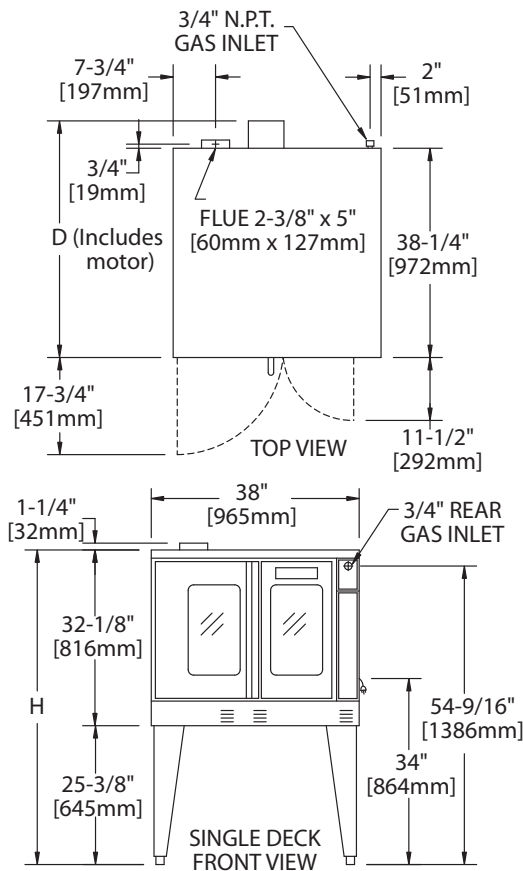

Installation Notes:

Combustible Wall Clearances:
 Sides: 1" (25mm)
 Back: 3" (76mm)

Entry Clearance:
 Crated: 47" (1194mm)
 Uncrated: 32 1/2" (826mm)

Manifold Operating Pressure:

Natural: 4.5" WC (11 mbar)
 Propane: 10" WC (25 mbar)
 Max 13.8" WC @ 70°F

NOTE: Data applies only to North America

Notes:

- Standard electrical specifications include motor requirements.
- (120V units) 115V, 3/4 HP, 2-speed motor; 1140 and 1725 rpm, 60Hz.
- (240V units) 200-240V, 3/4 HP, 2-speed motor; 1140 and 1725 rpm, 60 Hz
- A 6 ft. line cord is provided for each 120V deck with a (NEMA #5-15P) plug.
- Garland recommends a separate 15 AMP circuit for each 120V unit.

Gas Input Ratings shown here are for installations up to 2,000 ft. (610m) above sea level. Specify altitudes over 2,000 ft. Please specify- gas type when ordering.

Form# MCO10S (07/22/11)