



Master Series Heavy Duty Upright Broiler

Item: _____
 Quantity: _____
 Project: _____
 Approval: _____
 Date: _____

Master Series Heavy Duty Upright Broiler

Models:

- M100XRM M100XSM M100XTM

Infra Red Broiler with Upper Finishing oven



Model M100XRM

Standard Features:

- Stainless steel front and sides
- 6" (152mm) chrome steel adjustable legs
- 7-1/2" (191mm) stainless steel front rail
- Porcelain interior finishing oven
- Four direct radiant, infra-red burners, 17,500 BTU, (5.14 kW) each
- 120 volt air intake blower motor
- Air-proving safety switch
- Removable broiler grid
- 3 position adjustable rack
- Large capacity, easily removable broiler chamber grease container located out of the heat zone
- Two (2) Hi/Med/Lo independent heat controls for broiling chamber
- 40,000 BTU (11.72 kW - natural gas)/35,000 BTU (10.25 kW - propane), cast iron oven burner
- Piezo spark ignition for oven
- Fully porcelainized oven interior

Optional Features:

- Stainless steel main back
- Convection oven base, add C to Model No., e.g. M100XRC
- Additional oven rack
- 3/4" rear gas connection (stand alone) ;1-1/4" NPT rear gas connection (battery installation)
- End caps and cover (NC - specify)
- Swivel casters (4) w/front brakes
- Polyurethane non-marking swivel casters (4) w/front brakes
- 6" (152mm) stainless steel adjustable legs
- Toe base (not for use with "RC" oven)
- Storage cabinet with doors
- Celsius dial for oven thermostat (NC)

Specifications:

Heavy-duty gas infra-red broiler with oven and upper finishing oven, Model #M100XR. Four (4) 17,500 BTU (5.14kW) direct radiant, infra-red burners. Adjustable broiler rack with removable grid. Fan-assisted clean air delivery system for broiler section. Porcelain enamel oven interior with 40,000 BTU (11.72 kW) cast iron oven burner. Standard with stainless steel front and sides. Two independent heat controls, (left and right), for broiling chamber. Natural or propane gas. Also available with storage base w/ doors, M100XSM, and modular top, M100XTM.



NOTE: Broilers supplied with casters must be installed with an approved restraining device.



Product	Width: In(mm)	Depth: In(mm)	Height: In(Mm) (w/ NSF Legs)	Oven/Storage Base Interior: In(mm)		
				Width	Depth	Height
M100XRM	34(864)	38(965)	72-1/8(1831)	26-1/4(667)	29(737)	13-1/2(343)
M100XSM	34(864)	38(965)	72-1/8(1831)	26(665)	30-1/2(773)	20-1/2(519)
M100XTM	34(864)	38(965)	44-1/2(1130)	N/A	N/A	N/A

INPUT (Natural Gas)	M100XRM		M100XSM		M100XTM	
	BTU	kW	BTU	kW	BTU	kW
Top Section	70,000	20.56	70,000	20.56	70,000	20.56
Oven	40,000	11.72	N/A	N/A	N/A	N/A
TOTAL	110,000	32.28	70,000	20.56	70,000	20.56

RC=Range w/Convection Oven R=Range w/Oven S=Range w/Storage Base T=Modular Top

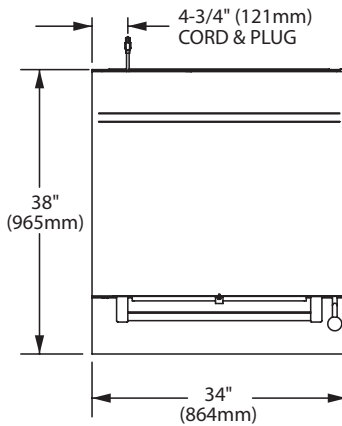

Combustible Wall Clearances ¹	Entry Clearances	Operating Pressure
Sides: 6" (152mm) Back: 6" (152mm)	Crated: 39-1/4" (997mm) Uncrated: 34-1/4" (870mm)	Natural: 6" WC (15mbar) Propane: 11" WC (28mbar)

¹NOTE: Installation clearance reductions are applicable only where local codes permit. Data applies only to North America

Gas input ratings shown here are for installations up to 2,000 ft. (610m) above sea level. Specify altitudes over 2,000 ft.

Commercial cooking equipment requires an adequate ventilation system. For additional information, refer to the National Fire Protection Association's standard NFPA96. (for North America only)

Electrical characteristics eaRC oven: 1/3HP motor, 120 VAC, single phase, 3.4 amps. Please specify gas type when ordering.

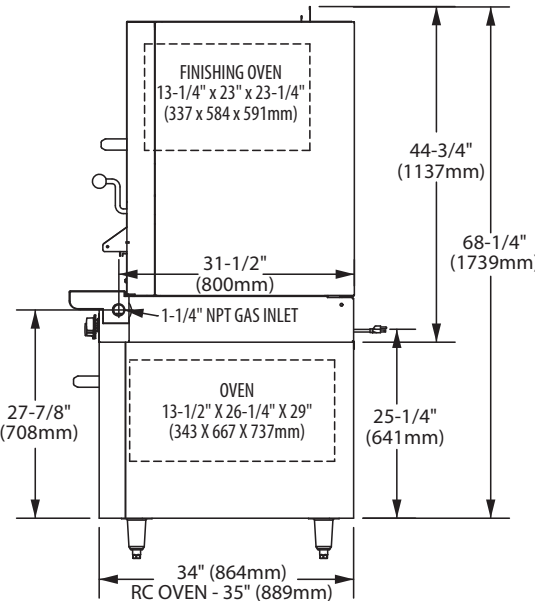
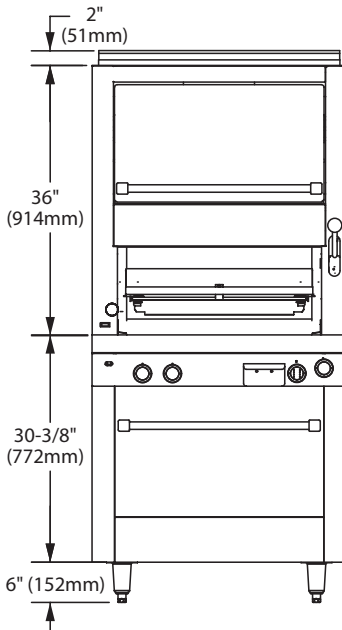

Shipping Wt: (Lb/Kg) - Cu Ft
M100XRM: 700/318 - 70
M100XSM: 600/273 - 70
M100XTM: 510/232 - 50

Form# M100XM (08/03/11)