

# Garland

## G Series 48" Gas Restaurant Range

Item: \_\_\_\_\_  
 Quantity: \_\_\_\_\_  
 Project: \_\_\_\_\_  
 Approval: \_\_\_\_\_  
 Date: \_\_\_\_\_

G Series 48" Gas Restaurant Range

### Models:

- |                                  |                                     |                                     |                                     |                                    |
|----------------------------------|-------------------------------------|-------------------------------------|-------------------------------------|------------------------------------|
| <input type="checkbox"/> G48-8RS | <input type="checkbox"/> G48-6G12RS | <input type="checkbox"/> G48-4G24RS | <input type="checkbox"/> G48-2G36RS | <input type="checkbox"/> G48-G48RS |
| <input type="checkbox"/> G48-8SS | <input type="checkbox"/> G48-6G12SS | <input type="checkbox"/> G48-4G24SS | <input type="checkbox"/> G48-2G36SS | <input type="checkbox"/> G48-G48SS |
| <input type="checkbox"/> G48-8LL | <input type="checkbox"/> G48-6G12LL | <input type="checkbox"/> G48-4G24LL | <input type="checkbox"/> G48-2G36LL | <input type="checkbox"/> G48-G48LL |



Model G48-8LL

NOTE: Ranges supplied with casters must be installed with an approved restraining device.

### Standard Features:

- Large 27" (686mm) work top surface
- Stainless steel front and sides
- Stainless steel 5" (127mm) plate rail
- Stainless steel backguard, w/removable stainless steel shelf
- 12" (305mm) section stamped drip trays w/ dimpled bottom
- 6" (152mm) adj. stainless steel legs
- Large easy-to-use control knobs
- Gas regulator

### Standard on Applicable Models:

- Cabinet base in lieu of oven
- Ergonomic split cast iron top ring grates
- 33,000 Btuh/ 9.67 kW 2 piece cast iron Starfire- Pro open top burner
- 5/8" (15mm) thick steel griddle plate w/manual hi/lo valve control, 23" (584mm) working depth surface, Standard on right, optional on left
- 4-1/4" (108mm) wide grease trough
- 18,000 Btuh/5.27 kW cast iron "H" style griddle burner per 12"(305mm) width of griddle
- 32,000 Btuh/ 9.38 kW (space saver) or 38,000 Btuh/ 11.13 kW cast iron "H" style oven burner
- Snap action modulating oven thermostat low to 500° F
- Porcelain oven interior, std. oven fits sheet pans 18x26 in both directions
- Nickel plated oven rack and 3-position removable oven rack guide
- Strong, keep-cool oven door handle

- Convection oven w/3 nickel plated oven racks and removable rack guides in lieu of standard oven w/ 1/3HP 120v 60 Hz single phase fan motor; change Suffix RS to CS

### Optional Features:

- Convection oven motor 240v 50/60HZ single phase
- Snap action modulating griddle control 175° to 425° F
- Grooved griddle in 1/2 or full plate section widths
- Hot top 12" (305mm) plate in lieu of two open burners, manual valve controlled w/18,000 Btuh/5.27 kW cast iron "H" burner standard on left side
- Low profile 9-3/8" (238mm) backguard stainless steel front and sides
- Stainless steel back for high shelf, low profile backguard or range
- Additional oven racks
- 6" (152mm) levelling swivel casters (4), w/front locking
- Flanged deck mount legs
- Stainless steel door for storage models: double storage models (SS) 18-15/16" (481mm) wide per section, standard oven with small storage models 15-3/4" (400mm) wide
- Intermediate stainless steel shelf for storage base models, 12" or 24" wide
- Celsius temperature dials
- Piezo spark ignition for pilots on griddles

### Specifications:

Gas restaurant series range with 2 space saver ovens, 20" (508mm) wide or large capacity oven 26-1/4" (667mm) wide. 47-1/4" wide, 27" (686mm) deep work top surfaces. Stainless steel front, sides and 5" wide front rail. 6" (152mm) legs with adjustable feet. Eight Starfire-Pro 2 piece, 33,000 Btuh/ 9.67 kW (natural gas), cast open burners set in split cast iron ergonomic grates. Griddle or optional hot top with cast iron "H" style burners, 18,000 Btuh/5.27 kW (natural gas), in lieu of open burners. One piece oven with porcelain interior and heavy duty, "keep cool" door handle. Heavy cast iron "H" oven

burner rated 32,000 Btuh/ 9.38 kW (natural gas) for space saver oven, and 38,000 Btuh/11.13 kW (natural gas) for standard oven. Oven controlled by even bake, fast recovery snap action modulating oven thermostat. Available with convection oven in lieu of standard oven or storage base in lieu of oven(s).



Garland Commercial Ranges Ltd.  
 1177 Kamato Road,  
 Mississauga, Ontario  
 L4W 1X4 CANADA

General Inquires 1-905-624-0260  
 USA Sales, Parts and Service 1-800-424-2411  
 Canadian Sales 1-888-442-7526  
 Canada or USA Parts/Service 1-800-427-6668



OB=Open Burners

G=Griddle

O=Oven(s)

Shipping volume, all models= 65 cu ft

Model Number	OB	G	O	Total BTU/Hr Natural	Ship Wt.	
					Lbs.	Kg
G48-8LL	8	—	(2) 20"	328,000	572	259
G48-8RS <sup>1</sup>	8	—	(1) 26"	302,000	539	264
G48-8SS	8	—	—	264,000	402	182
G48-6G12LL	6	12"	(2) 20"	280,000	602	273
G48-6G12RS <sup>1</sup>	6	12"	(1) 26"	254,000	569	258
G48-6G12SS	6	12"	—	216,000	432	196
G48-4G24LL	4	24"	(2) 20"	232,000	667	303
G48-4G24RS <sup>1</sup>	4	24"	(1) 26"	206,000	604	274

Model Number	OB	G	O	Total BTU/Hr Natural	Ship Wt.	
					Lbs.	Kg
G48-4G24SS	4	24"	—	168,000	497	255
G48-2G36LL	2	36"	(2) 20"	184,000	672	305
G48-2G36RS <sup>1</sup>	2	36"	(1) 26"	158,000	639	290
G48-2G36SS	2	36"	—	120,000	502	228
G48-G48LL	—	48"	(2) 20"	136,000	692	314
G48-G48RS <sup>1</sup>	—	48"	(1) 26"	110,000	659	299
G48-48GSS	—	48"	—	72,000	522	237

<sup>1</sup> Available with convection oven change RS to CS

Width In (mm)	Depth <sup>2</sup> In (mm)	Height w/shelf In (mm)	Oven Interior-in (mm)			Combustible Wall Clearance-In (mm)		Entry Clearances In (mm)		Manifold Operating Pressure	
			Height	Depth <sup>3</sup>	Width <sup>4</sup>	Sides	Rear	Crated	Uncrated	Natural	Propane
47-1/4 (1200)	34-1/2 (876)	57 (1448)	13 (330)	26 (660)	26-1/4 (667)	14 (356)	6 (152)	37 (940)	36-1/2 (927)	4.5" WC 11 mbar	10.0" WC 25 mbar

<sup>2</sup> Convection oven base models add 3 7/8" (98mm) to the depth of the unit. <sup>3</sup> Convection oven depth 22" (559mm)

<sup>4</sup> Space-saver oven is 20" (508mm) wide Note: Installation clearance reductions are applicable only where local codes permit.

SPACE SAVER OVEN MODEL

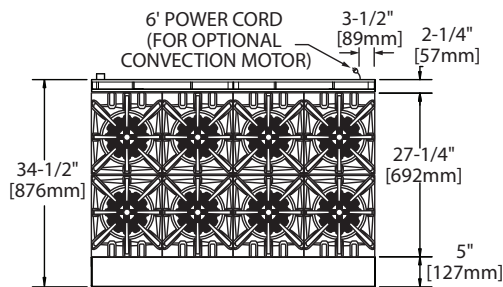

Burner Ratings (BTU/Hr/kW)				
Gas Type	Open Top	Griddle/ Hot Top	Standard Oven or Convection	Space Saver Oven
Natural	33,000/9.67	18,000/5.27	38,000/11.13	32,000/9.38
Propane	26,000/7.61	18,000/5.27	32,000/9.38	28,000/8.20

Convection ovens with 120V, 60 Hz, 1 phase, 3.4 amps motors are supplied with 6'/1829mm cord and plug (NEMA 5-15P); 240V, .50/60 Hz, 1 phase motors are not supplied with cord and plug and must have direct connect.

Gas input ratings shown for installations up to 2000 ft.,(610m) above sea level. Please specify altitudes over 2000 ft.

This product is not approved for residential use.

FULL SIZE OVEN SHOWN ON LEFT, STANDARD ON RIGHT

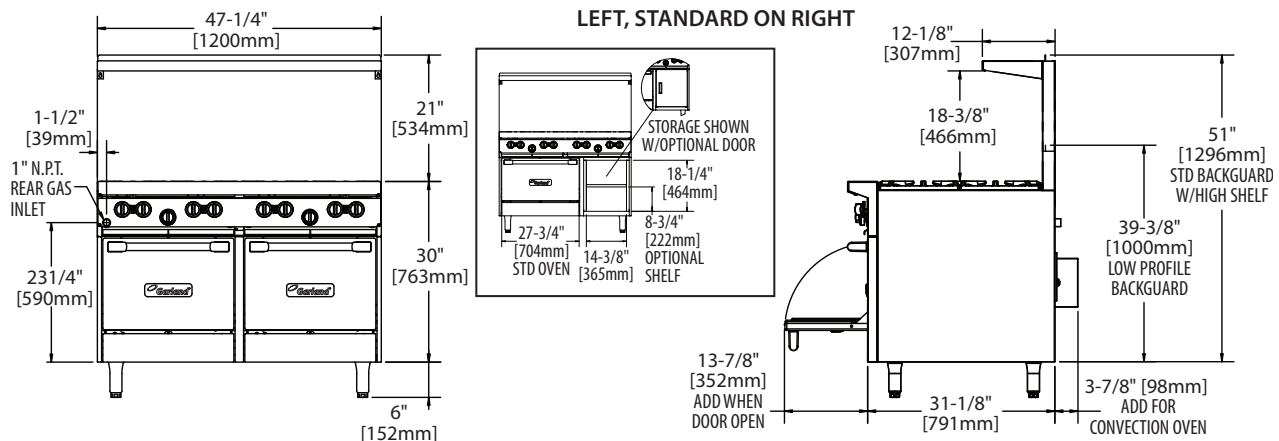

Form# G48 (07/28/11)