



PROJECT:

MODEL:

QUANTITY:

ITEM NO:

MOBILE BARS & BACK-UP

For Conventional Beverage Service Using Cans and Bottles

PREMIER "PS-CB SERIES"

Premier Series

MOLDED LAMINATE

Exterior with Stainless Steel Working Side



PS-CB-8



PS-CB-6

PS-IC-200
Ice Storage Cart

Durable laminate replicating the elegance of fine furniture.

FWE Conventional "Premier Series" Bars provide ample storage of beverage cases and glass racks while supporting the weight of cans and bottles like no other! Built tough to stand up under years of continuous use, our top and bottom, precision welded tubular base frames prevent sagging or twisting.

The stainless steel work surface is easy to clean and holds up to many years of service. Stainless steel storage areas make this the ultimate work horse while providing a mobile beverage station to host any occasion.

Stainless steel speed rails keep bottles upfront for efficient and convenient dispensing. Built-in partitions prevent bottle breakage.

The sleek black serving top and Cherry laminate exterior finish are standard.

For years of reliable, profitable service, ask for FWE "Premier Series" - the "Toughest Bar in Town".

- ◇ Welded steel top and bottom frames
- ◇ Raised marine front edge retard spills
- ◇ Rugged polyurethane tire casters
- ◇ Stainless steel work surface and splash area with coved corners
- ◇ Stainless steel ice sink with shut-off drain valve
- ◇ Cherry molded laminate exterior finish
- ◇ Black laminate top with bull-nose rounded corners
- ◇ Removable bottle speed rack
- ◇ Handy underbar server with 4 bowls
- ◇ Towel ring
- ◇ Large storage areas
- ◇ Two year limited warranty



TM

PROJECT:

MODEL:

QUANTITY:

ITEM NO:

SPECIFICATIONS:

PREMIER "PS-CB SERIES" BARS available with matching Back-Up Bar and Ice Cart

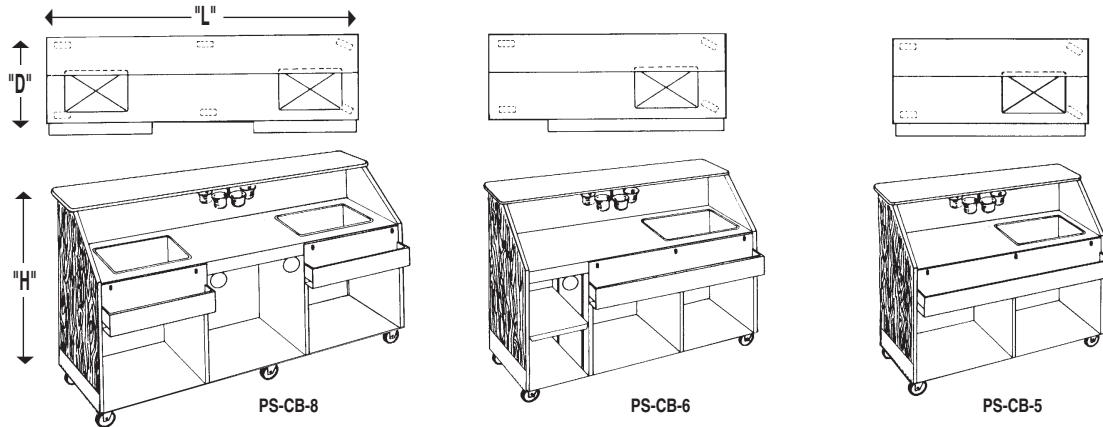

BAR SPECIFICATIONS:

MODEL NUMBER	LENGTH	WORKING AREA HEIGHT [A]	BULK STORAGE AREA	BOTTLE RACK CAPACITY [B]	CASTER SIZE	SHIP WT. LBS. (KG)
PS-CB-5	60" (1524)	35.5" (902)	27"H x 23" D	8 qts	5"	488 (221)
PS-CB-6	73" (1854)	35.5" (902)	27"H x 23" D	12 qts	5"	508 (231)
PS-CB-8 [C]	96" (2438)	35.5" (902)	27"H x 23" D	16 qts	5"	520 (236)

Consult Factory for SHIPPING CLASS

[A] Overall dimensions are 46.5" H x 28.5" D.

[B] Removable bottle speed rack extends 3.5" beyond depth dimension of 31.5".

[C] Dual station model furnished with 2 sinks.

BACK-UP SPECIFICATIONS:

"PREMIER SERIES" COMPANION PIECE				
MATCHING ICE CART 200 lb. capacity	HIGH "H"	DEEP "D"	WIDE "W"	 Holds 200 lbs. of ice! Fully insulated. Flip-top stainless lid. Drain, push bar handle, and all swivel 5" casters. Welded steel frame.
PS-IC-200	33.5" (851)	24.5" (622)	24.5" (622)	

EXTERIOR. Classic raised panel style molded exterior laminate. Durable solid serving surface. Solid brass kick plate provided in front and sides of unit. Constructed with reinforced joints for additional strength and durability.

INTERIOR (WORKING SIDE). Heliarc welded single unit construction shall consist of welded base worktop frame of 1" square steel tubing. Base frame shall have additional 10-gauge stainless steel corner plate reinforcements. Full length heavy gauge stainless steel angles reinforce front corners of body on inside, with high impact edging on outside corners. Work surface shall be constructed of 20-gauge stainless steel.

Interior of body shall be lined with 24-gauge stainless steel bonded to walls and bottom storage area. Seams shall overlap for greater durability and moisture resistance. Work and splash areas shall be polished stainless steel with easy-to-clean coved corners. Front edge of work area shall have raised marine nosing to retard spills.

CASTERS. Maintenance free polyurethane tire casters in a configuration of two (2) rigid and two (2) swivel with brake. Casters shall have a reinforced yoke mounted to 10-gauge caster plate. The caster mounting plate shall be secured to a 10-gauge stainless steel reinforcing stress plate via welded in place stainless steel studs. The reinforcing stress plates shall be welded to the heavy gauge tubular frame of the unit. Eight (8) foot models are equipped with six (6) casters: four (4) rigid casters and two (2) swivel with brake.

STORAGE AREA. On six (6) foot models, the glass storage area shall include removable and adjustable stainless steel shelf. On all models, the bottom storage area shall be stainless steel lined.

ICE SINK. Sink shall be one-piece stainless steel with coved corners: 19.75" x 12.75" x 10.5" deep. Sink shall have enclosed foam insulation with drain. Sink shall have a capacity of 60 lbs. of ice, and be provided with a stainless steel sliding cover.

BAR ACCESSORIES. Standard equipment shall include 5" deep, heavy gauge stainless steel bottle speed rack extending 3.5" beyond depth dimension of 31.5"; removable without tools. Underbar server shall have four (4) removable condiment holders. Towel ring shall be provided under top work surface.

Optional Accessories:

- Locking bottle speed rack
- Extra stainless steel shelves
- Locking doors for shelf area
- Stainless steel bar gutters
- Protective storage cover
- Floor locks (set of 2)
- All swivel casters
- All swivel with brake casters

FWE Products are used by major companies world-wide. We can modify, design, or custom build equipment to fit your special requirements.



Food Warming Equipment Company, Inc.

P.O. Box 1001
Crystal Lake, IL 60039 USA
800-222-4393; 815-459-7500
Fax: 815-459-7989

Manufacturing Facilities:
7900 S. Route 31
Crystal Lake, IL 60014 USA
www.FWE.com sales@fweco.net

FWE products may be covered under one or more of the following U.S. patents: 288,299; 238,300; 3,952,609; 4,192,991.

All specifications subject to change without notice. © 09D Food Warming Equipment Company, Inc.