



PROJECT:

MODEL:

QUANTITY:

ITEM NO:

MOBILE BARS & BACK-UP

For Beverage Service Using Pre-Mix / Post-Mix / Bag-in-Box

ARCHITECTURAL "AS-BBC-MW SERIES"

Architectural Series

SOLID MAHOGANY

Exterior with Stainless Steel Working Side



AS-BBC-6-MW
Mahogany with a Cherry finish



AS-BBC-8-MW-PO
Shown with optional
Post-Mix Dispensing System

Specify Dispensing System Sink and Fittings at time of order:

- "PR" for Pre-Mix Dispensing System
- "PO" for Post-Mix Dispensing System
- "PO-BIB" for Post-Mix Bag-in-Box Dispensing System

Note: Additional charges for factory installation of beverage dispensing system.



made to serve you better

Elegant wood furniture and classic old world craftsmanship that exceed any operations expectations!



TM

Why compromise? If you're looking for that one of a kind, "signature" mobile bar to personalize your operation, look no further! FWE's years of innovative design experience and reputation for the industry's best built portable bars have culminated in the ultimate statement in beverage dispensing.

With FWE portable bars, you can add grace to your overall ambiance, rather than detract from it. Fashioned in traditional wood with old world craftsmanship, our Architectural Series Mahogany Bars feature classic raised solid wood panels, elegant fluted columns, and an over-sized "Chicago Arm" bar top, all hand finished in a rich Cherry stain. Combined with superior base frame, heavy-duty poly casters, and interior stainless steel construction, these individually crafted bars blend elegant form with efficient function.

Lend an air of distinction with ultimate performance and profitability. FWE's Architectural Series bars are clearly the "Choice of the Professionals".

- ◇ Genuine solid Mahogany decorative exterior
- ◇ Heliarc welded, heavy-duty construction
- ◇ Heavy gauge square steel tubing base frame
- ◇ 10-gauge stainless steel corner plate reinforcements
- ◇ Stainless steel interior, bonded to walls with overlapping seams
- ◇ Raised marine front edge retard spills
- ◇ Rugged polyurethane tire casters
- ◇ 6 circuit sealed-in cold plate sink
- ◇ 60 lb. ice capacity with stainless steel sliding cover
- ◇ Stainless steel work surface and splash area with coved corners
- ◇ Removable bottle speed rack
- ◇ Handy underbar server with 4 bowls
- ◇ Towel ring
- ◇ Tank storage area
- ◇ Opening(s) for dispensing gun tubing
- ◇ Tank retainer strap
- ◇ Two year limited warranty

PROJECT:

MODEL:

QUANTITY:

ITEM NO:

SPECIFICATIONS: ARCHITECTURAL "AS-BBC-MW SERIES" BARS

available with matching Back-Up Bar and Ice Cart

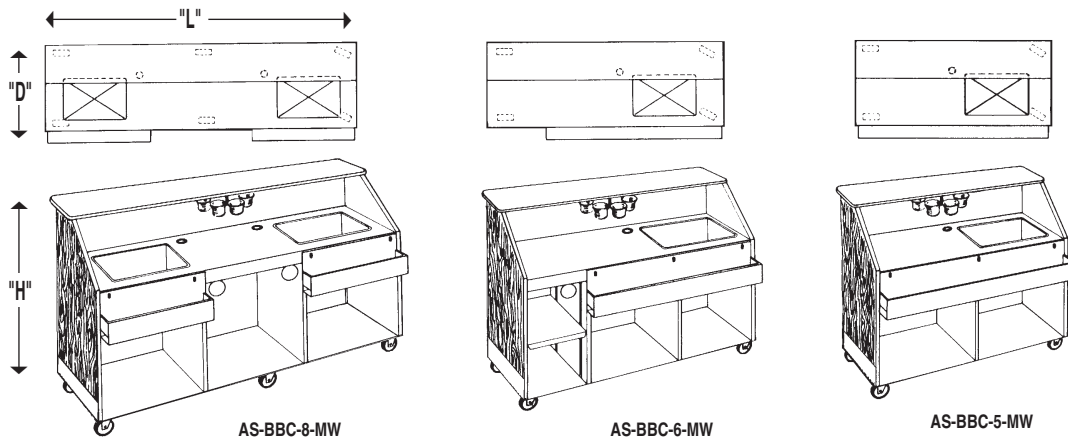

BAR SPECIFICATIONS:

"ARCHITECTURAL SERIES" BARS					Consult Factory for SHIPPING CLASS	
MODEL NUMBER	LENGTH	WORKING AREA HEIGHT [A]	PRE-MIX TANK CAPACITY	BOTTLE RACK [B] CAPACITY	CASTER SIZE	SHIP WT. LBS. (KG)
AS-BBC-5-MW	60" (1524)	35.5" (902)	4	8 qts	5"	525 (237)
AS-BBC-6-MW	75" (1905)	35.5" (902)	6	12 qts	5"	595 (268)
AS-BBC-8-MW[C]	96" (2438)	35.5" (902)	8	16 qts	5"	735 (331)

[A] Overall dimensions are 46.5" H x 28.5" D.

[B] Removable bottle speed rack extends 3.5" beyond depth dimension of 31.5".

[C] Dual station model furnished with 2 sinks.

BACK-UP SPECIFICATIONS:

"ARCHITECTURAL SERIES" COMPANION PIECES			
MATCHING BACK BAR	LENGTH	WORKING AREA HEIGHT	OVERALL HEIGHT
AS-PSC-6-MW	73" (1854)	39.75" (1010)	78.5" (1994)
			MATCHING ICE CART 200 lb. capacity AS-IC-200-MW Height: 33.5" (851) Deep: 24.5" (622) Width: 24.5" (622)
			Holds 200 lbs. of ice! Fully insulated. Flip-top stainless lid. Drain, push bar handle, and all swivel 5" casters. Welded steel frame.

EXTERIOR. Classic raised solid Mahogany wood panels, fluted columns, crown molding and beveled edge "Chicago Arm" style bar top. Durable solid serving surface. Solid brass kick plate provided in front and sides of unit. All wood surfaces finished with polymer coating to deter scratching and gouging. Constructed with reinforced joints for additional strength and durability. Solid hardwood: Mahogany; Finish: Cherry.

INTERIOR (WORKING SIDE). Heliarc welded single unit construction shall consist of welded base worktop frame of 1" square steel tubing. Base frame shall have additional 10-gauge stainless steel corner plate reinforcements. Full length heavy gauge stainless steel angles reinforce front corners of body on inside, with high impact edging on outside corners. Work surface shall be constructed of 20-gauge stainless steel. Interior of body shall be lined with 24-gauge stainless steel bonded to walls and bottom storage area. Seams shall overlap for greater durability and moisture resistance. Work and splash areas shall be stainless steel with easy-to-clean coved corners. Front edge of work area shall have raised marine nosing to retard spills.

CASTERS. Maintenance free polyurethane tire casters in a configuration of two (2) rigid and two (2) swivel with brake. Casters shall have a reinforced yoke mounted to 10-gauge caster plate. The caster mounting plate shall be secured to a 10-gauge stainless steel reinforcing stress plate via welded in place stainless steel studs. The reinforcing stress plates shall be welded to the heavy gauge tubular frame of the unit. Eight (8) foot models are equipped with six (6) casters: four (4) rigid casters and two (2) swivel with brake.

ICE SINK WITH SEALED IN COLD PLATE. Sink shall be one-piece stainless steel with coved corners: 19.75" x 12.75" x 10.5" deep. Sink shall have enclosed foam insulation with drain and line fittings. 6 circuit sealed-in cold plate shall be compatible for use with Pre-Mix, Post-Mix, and Bag-in-Box systems. Sink shall have a capacity of 60 lbs. of ice, and be provided with a stainless steel sliding cover. Specify system to be used: Pre-Mix, Post-Mix or Bag-in-Box.

STORAGE AREA. On six (6) foot models, the glass storage area shall include removable and adjustable stainless steel shelf. On all models, the bottom storage area shall be stainless steel lined.

Tank storage area shall accommodate a minimum of four (4) 5-gallon premix tanks, and CO₂ tank, and a tank retainer strap shall be provided.

BAR ACCESSORIES. Standard equipment shall include 5" deep, heavy gauge stainless steel bottle speed rack extending 3.5" beyond depth dimension of 31.5"; removable without tools. Underbar server shall have four (4) removable condiment holders. Towel ring shall be provided under top work surface.

Optional Accessories:

- Locking bottle speed rack
- Extra stainless steel shelves
- Locking doors for shelf area
- Stainless steel bar gutters
- Pre-mix dispensing equipment
- Post-mix dispensing equipment
- Bag-in-Box dispensing equipment
- Protective storage cover
- All swivel casters
- All swivel with brake casters

BAR COMPANION PIECES:

MATCHING BACK BAR WITH MIRRORRED CANOPY.

Super back-up! Stores extra liquor, glasses and bar accessories. Convenient work / serve top in choice of laminate. Recessed can lights above handsome Mirrored Canopy. Interior shelves adjustable on 1.5" spacings. Welded steel frame assures years of profitable use. Large 5" casters with brakes allows easy mobility.

MATCHING ICE STORAGE CART.

Holds 200 lbs. of ice! Fully insulated. Flip-top stainless lid. Drain, push bar handle, and all swivel 5" casters. Welded steel frame. 33.5" (H) x 24.5" (D) x 24.5" (W).

FWE Products are used by major companies world-wide. We can modify, design, or custom build equipment to fit your special requirements.



Food Warming Equipment Company, Inc.

P. O. Box 1001
 Crystal Lake, IL 60039 USA
 800-222-4393; 815-459-7500
 Fax: 815-459-7989

Manufacturing Facilities:
 7900 S. Route 31
 Crystal Lake, IL 60014 USA
 www.FWE.com sales@fweco.net

FWE products may be covered under one or more of the following U.S. patents: 288,299;238,300;3,952,609;4,192,991.

All specifications subject to change without notice. © 09D Food Warming Equipment Company, Inc.