

# Installation, Service Instructions & Parts



## AR30 Front Open Self Contained Water Supply Counter Top Steamer Half Size Pan 120V and 240V Models (240V Model for Export ONLY)

**CAUTION:** This steamer to be used with distilled water only (demineralized). Without treated water, deposits can build up in steam generators causing reduced steam volume and eventual stoppage of steam production. Clogged or limed steam generators caused by use of non-distilled water will not be covered under the terms of the warranty.

AR Series -Self Contained Water Reservoir and Pump - Stainless steel construction, Top injecting, portable, removable water drawer, manual pump or timer, 6' - 3 wire cord.

Special Note: The AR Series requires distilled or demineralized water. Clogged or limed generators caused by use of non-treated water will not be covered under the terms of the warranty.

#### Specifications:

- 120 volts 60HZ AC 1500 watts, max 13 amp
- 240 volts 60HZ AC 1500 watts, max 6.3 amp (240V model is Export Only and not UL listed)
- Manual water pump operation
- Closed generator
- Drawer style steamer

#### Warranty

See the back of this manual for warranty.

This warranty does not apply to damages resulting from accident, misuse, abuse or alteration.

No equipment may be returned without written authorization from EmberGlo (or Midco). Returned goods must be shipped prepaid to the factory.

Warranty form must be filled in and returned to EmberGlo to validate warranty. See warranty page for return instructions.

This manual contains sufficient information for installation of the EmberGlo Steamer in normal locations.

In the United States, installation must conform with local codes.

**PURCHASER: Retain these instructions for future use.** Post in a prominent location near the steamer.

**CAUTION:** Cooking equipment should be used in an environment protected by an automatic fire suppression system. Consult the National Fire Protection Association NFPA Code 96 or the latest edition of Standards for Installation of Equipment for Removal of Smoke and Grease-Laden Vapors From Commercial Cooking Equipment.

**WARNING: Improper installation, adjustment, alteration, service or maintenance can cause property damage, injury or death. Read the installation, operating and maintenance instructions thoroughly before installing or servicing this equipment.**

**AVOID ERROR IN PARTS SELECTION.** When ordering use complete EMBERGLO Part Number and Description. Furnish Model Number, Bill of Material Number and Serial Number (if available) from the specification plate found on the product. **IMPORTANT:** Availability of parts as well as specifications are subject to change without notice. Please consult factory for item availability.



**EmberGlo**

EmberGlo  
A Div of Midco International Inc.  
4140 West Victoria Street  
Chicago, Illinois 60646  
toll free 866.705.0514  
tel 773.604.8700  
fax 773.604.4070  
web www.emberglo.com  
e-mail sales@emberglo.com

**SAFETY INFORMATION TERMS:** The following terms are used to identify hazards, safety precaution of special notations and have standard meanings throughout this manual. They are printed in all capital letters using a bold type face as shown below, and preceded by the exclamation mark symbol. When you see the safety alert symbol and one of the safety information terms as shown below, be aware of the hazard potential.



- DANGER:** Identifies the most serious hazards which will result in severe personal injury or death.
- WARNING:** Signifies a hazard that could result in personal injury or death.
- CAUTION:** Identifies unsafe practices which would result in minor personal injury or product and property damage.

*Quality Designed for Proven Performance*



911  
8449 80  
Printed in USA

# AR30 - Installation and Service

## Installation

1. Position steamer on level surface and plug power cord into 3-hole 120 volt AC grounded receptacle. If an adapter is used, it must be grounded properly.
2. Pull out water pan and fill with distilled (NOT HOT OR BOILING) water to 1/4" from the top of the water pan baffles; then close drawer. Unit is now ready for operation.
3. **No Hood Installation Required:** According to the Uniform Mechanical Codes per the International Conference of Building Officials Code EmberGlo Steamers do not require a separate hood for vapor produced during operation. Also, there are no requirements in NSF Standard 4 (2006e) for steamers to have ventilation.

## Operation

1. Move toggle switch to ON position. The pilot indicating light remains on at all times. Allow 15-20 minutes to reach operating temperature.
2. Open food drawer, place food in pan; close drawer and operate lever as required per cooking guide.
3. At end of time cycle, open drawer and remove food.
4. Keep drawer closed when not in use.
5. To shut off unit move toggle switch to OFF position.

**⚠ Caution: Operate lever to the left and return to vertical position. Rapid repeated operation will over steam the unit. The amount of steaming necessary is determined by the type and amount of food to be heated. For more than one shot, wait 15 seconds between shots. A "shot" is one operation of the lever.**

## Maintenance Daily as Required

The food pan is removed by lifting up. Clean the inside thoroughly and wipe the outside to remove any material which might have accumulated.  
 - To remove the food drawer, pull the drawer out until it stops, release stop located at rear underside of drawer to unlock, and pull out the frame. Wipe the drawer and frame clean and return by inserting the drawer slide into the slide of the frame, then push the food pan to the rear until the lock engages automatically.

## Service

**⚠ DANGER: READ AND UNDERSTAND THIS BULLETIN THOROUGHLY BEFORE STARTING ANY TROUBLE SHOOTING. AN INADVERTENT SERVICE ERROR COULD RESULT IN SEVERE PERSONAL INJURY OR DEATH. ONLY A TRAINED EXPERIENCED SERVICE TECHNICIAN SHOULD ATTEMPT ANY REPAIR PROCEDURE.**

Qualified serviced agencies are available at most locations - Refer to EmberGlo listing of AUTHORIZED SERVICE AGENCIES included in Standard Equipment Catalog.

Note: Before attempting service, unplug power cord. For service or examination, all "working parts"

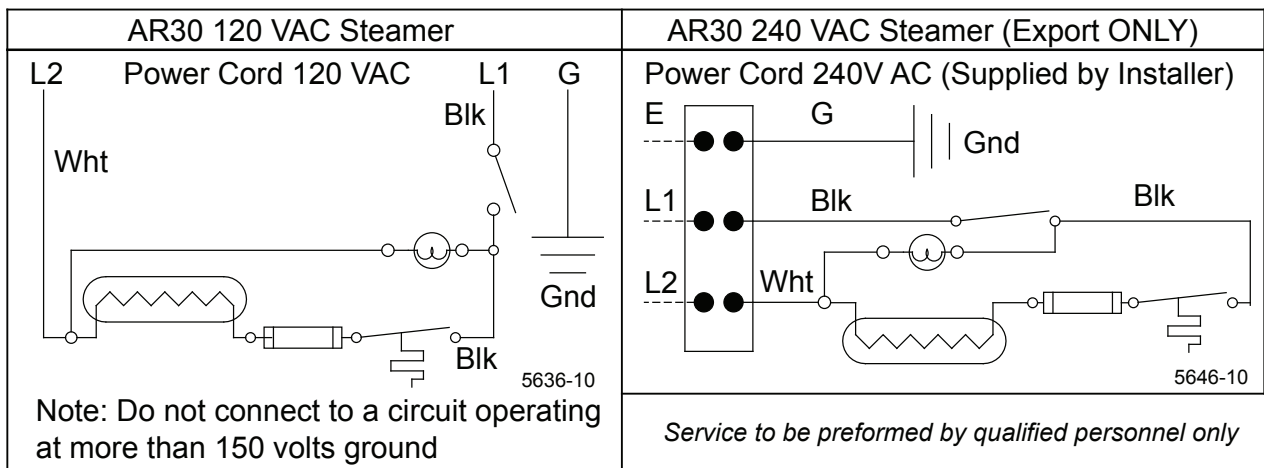

LEGEND	Symbol	Description	Symbol	Description	Symbol	Description
		Toggle Switch		Generator		Thermostat
	Pilot Light		Terminal Strip		Over Heat Protection Fuse	

Figure 1. Wiring for AR30 Steamer - 120V and 240V

of the steamer are exposed by removing first the cabinet top, then the back. The wiring diagram and spare cleanout gasket is located on inside of back.

### Electric Switch/Thermostat

The on-off switch should audibly "click" when operated manually. To determine if electrically operative, a continuity check should be made.

- The thermostat is adjusted at the factory default setting. It is not recommended to re-adjust the setting. If found defective it is recommended to replace.

### Pump System

Operate pump lever and observe length of pump shaft travel. It should travel approximately 5/8". If travel is less, check for broken or disengaged pins, links, crank.

- Disconnect brass fitting at water riser tube and bend tube up slightly so discharging water will clear front of unit. Operate pump lever; water should shoot out about 15 feet. If water does not shoot out, remove and inspect inlet tube assembly for leaks. Any air entering tube will break the suction on the water. Check installation and alignment of dip tube spring as detailed under next section. If water still doesn't shoot out, pump should be replaced.
- A strainer is located in the inlet tube at pump fitting. Loosen fitting and remove pump inlet tube. Dump strainer out of tube and wash under running water, then replace.

### Dip Tube and Spring

If the dip tube does not enter the water pan properly it must be replaced. When replacing, the open end or point of hook must be at the bottom and the eye must be in a vertical plane, like a coin standing on edge.

### Steam Generator

1. **To Clean.** Remove cabinet top and generator insulation. This will expose a square plate on the generator, which is removable for cleaning water passages.

- Check the three exposed holes when the clean-out cover is removed. If any of these holes are clogged, clean them out by hand-twisting a 7/64" drill for the center hole and a 3/16" drill for the two side holes.
- After thoroughly cleaning the three holes, plug in power supply and operate lever to steam unit. **THE UNIT MUST BE HOT.** Operate several times to blow out any accumulation.
- Replace the clean out cover, using new gasket. With the unit hot, operate lever. The unit should steam properly. If it does not, and the pump is operative as detailed under PUMP SYSTEM, the entire generator assembly is probably limed and must be disassembled and cleaned or replaced.



To clean generator assembly, separate casting from plate and clean lime from cavity in casting.



**Caution: Do not damage plate by scratching or polishing the finish.**

2. Information on use of the overheat label (8451-98)

**Caution: To prevent accidental shock, disconnect electrical plug from receptacle before attempting service.**

- An overheat label is located on the clean-out cover of the steam generator. The triangle in the center of the label, as shown below, is normally gold color. This triangle turns black at 450° F, indicating that the generator has overheated at least once. The operating temperature of the generator should be between 350° and 400° F. If it is not, the thermostat should be replaced.

Note: the overheat label will not return to its original gold color once it has turned black. It should be scraped off and replaced so that the thermostat can be monitored at all times. In addition, in the event that the thermostat has to be replaced, it is important to replace the label immediately afterwards so that someone at a later inspection will not suspect a faulty thermostat.

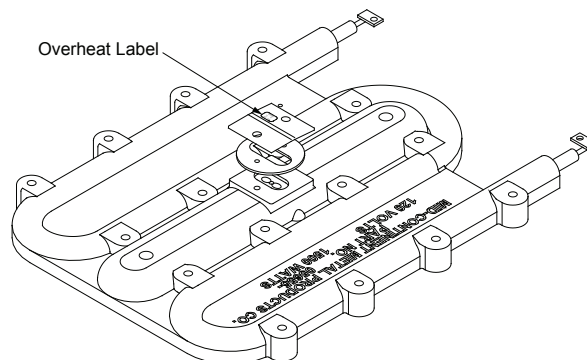
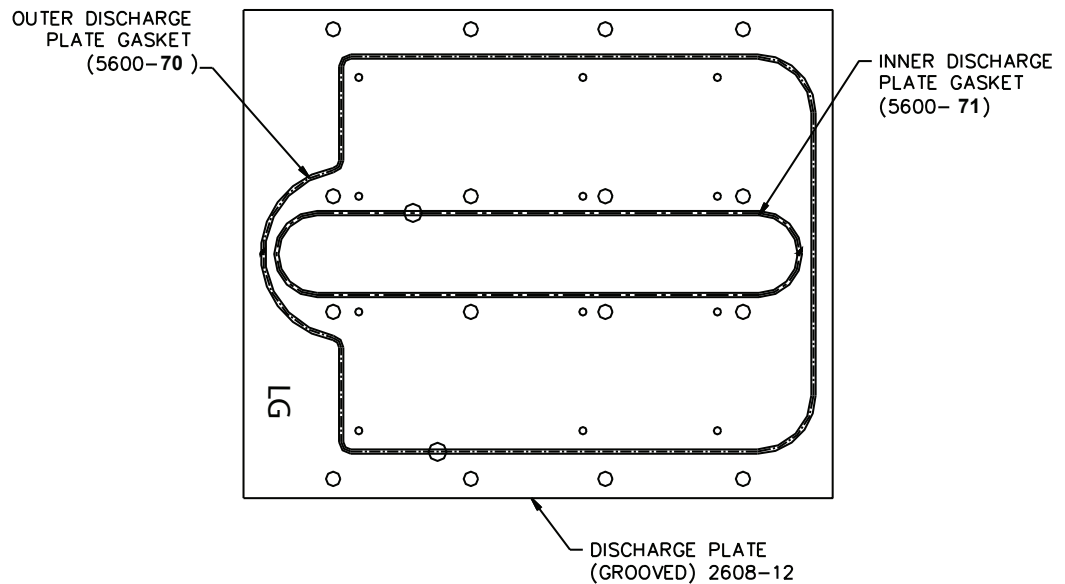

**Figure 2. Steam Generator Overheat Label Placement**

# AR30 - Service and Trouble Shooting

## Service Continued

3. **To Remove.**
  - Disconnect the water riser tube.
  - Disconnect electric wiring at the two terminals.
  - Remove 16 hex nuts. Note: Remove food drawer and hold screws up to prevent turning.
  - Lift off generator.
4. **To Replace.**
  - Install the gaskets in the discharge plate grooves as shown in Figure 3.
  - Place discharge plate & gasket assembly on the steamer (gasket facing up towards generator) so that steam holes line up with the twelve round holes in steam chamber.
  - Place the generator (#5655-90) on the above assembly so that mounting holes line up with the sixteen round holes in the discharge plate. Tape the carriage bolts in place from inside steam chamber and then tighten the nuts with lock washers. Remove all the tape.



*Figure 3. Generator Casting*

## Trouble Chart

1. Unit will not heat up; light out.
  - a. No power.
  - b. Plug out.
  - c. Loose internal connection.
  - d. Defective switch.
2. Unit will not heat up; light on.
  - a. Defective thermostat.
  - b. Loose heating element connection.
  - c. Defective generator unit.
  - d. Defective thermal fuse or open
3. Unit heats up light will not light.
  - a. Defective light in switch.
  - b. Loose connection.
4. Unit heats up; does not steam.
  - a. No water in pan.
  - b. Defective pump.
  - c. Cam, pins or linkage broken or disengaged.
  - d. Leak in inlet tube.
  - e. Dip tube spring assembly misaligned.
  - f. Clogged steam generator.

Note: If electrical trouble is other than loose connections, it is recommended that parts be replaced rather than repaired.

# Heating and Cooking Guide

## Cooking Instructions

These suggestions are made only to help the operator get started. Since each location will have different portions and different requirements, each operator must determine his own operation habits. Please remember that the steamer conserves its steam in the drawer and therefore does not often need repeated shots. The main exception is when frozen product must be defrosted.

**If a product is at room temperature or refrigerated**, start with 2 shots. This ensures that the food pan is full of steam.

**If a product is frozen**, start with 3 shots because condensation on the cold product eliminates the steam quickly.

### BREADS

Croissant.....
Dinner Rolls.....
Flour Tortillas.....
Hamburger Buns.....
Hard Rolls.....
Hoagies.....
Hot Dog Buns.....
Oat or Bran Muffins.....
Pastries.....

### MINUTES

1 Shot 15 Sec.
1 Shot-Wait 10-20 Sec.
1 Shot 15-30 Sec.
1 Shot Wait 10-20 Sec.
1-2 Shots-Wait 20-30 Sec.
1-2 Shots-Wait 20-30 Sec.
1 Shot Wait 10-20 Sec.
1-2 Shots Wait 25-45 Sec.
1-2 Shots-Wait 20-30 Sec.

### EGGS

Hard Boiled.....
Soft Boiled.....
Poached.....
Scrambled (12).....

10-20 minutes
4 minutes
3-4 Shots-3 minutes
8-10 minutes

### PASTA (pre-cooked refrigerated)

Macaroni and Cheese casserole .....
Rice.....
Spaghetti.....

3 Shots 90-120 Sec.
2 Shots 45-60 Sec.
2 Shots 45-90 Sec.

### SEAFOOD

Clams and Oysters.....
Crab, King (1 lb.).....
Lobster Tail (8 oz.) 4 pcs.....
Lobster Tail, frozen (8 oz.) 4 pcs.....
Lobster, whole.....
Orange Roughy Fillet.....
Shrimp, fresh (1 lb.).....
Shrimp, frozen (1 lb.).....
Scallops, large.....

7 minutes
4-5 minutes
13 minutes
10 minutes
6-8 minutes
6-7 minutes
5-7 minutes
6-8 minutes
6-8 minutes

### MEATS

Bacon (pre-cooked).....
Bratwurst (pre-cooked).....
Chicken (1/2 lb. pre-cooked).....
Deli Meats.....
Hamburger (pre-cooked).....
Hot Dogs, 10 per lb. (1 lb.).....
Ribs (pre-cooked).....
Sausage links (pre-cooked).....
Tamales.....
Tamales, frozen.....

45 Sec.
5 minutes
3-4 minutes
45-60 Sec.
1-2 minutes
3 minutes
2-4 minutes
1-2 minutes
4 minutes
6-7 minutes

### VEGETABLES

Artichoke.....
Asparagus.....
Broccoli, whole (1-2 lbs.).....
Brussel Sprouts.....
Carrots, sliced.....
Cauliflower, whole (1-2 lbs.).....
Corn on the cob.....
Flowerets, various.....
Green Beans (1 lb.).....
Potatoes, whole (small).....
Potatoes, mashed (2 quarts).....

25-30 minutes
8-10 minutes
10-12 minutes
12-15 minutes
7-8 minutes
12-15 minutes
5 minutes
5 minutes
12-15 minutes
20 minutes
6 minutes





**Warranty**  
**Midco® International Inc Limited Warranty Policy**  
**Exclusions Terms, Customer Requirements and Instructions**

**All claims should be filed through Warranty Central.**  
**Call factory for information (773 604 8700)**

Only Authorized Service Providers are authorized to provide Warranty service on all EmberGlo®, a Division of Midco® International Inc., food equipment as described under and Midco® International Warranty Policy. A list of providers can be found on our web site: [www.emberglo.com](http://www.emberglo.com)

**Provisions:**

In lieu of an implied warranty, all repairs and replacement parts furnished under our Warranty shall be f.o.b. point of distribution, but the owner must pay the necessary freight, delivery and labor costs involved when required. Any Federal, State or Local taxes are also extra. This Warranty is effective for a period of one year from date of installation. EmberGlo® Char Broilers and EmberGlo® Electric Food Preparation Equipment manufactured by Midco International, sold under the EmberGlo® trademark, are guaranteed to be free from defect in material and workmanship under normal use and service for a period of 1 (one) year after the date of original installation. Midco's obligation under this Warranty Policy shall be limited to repairing or replacing, at our option, any part of said equipment which Midco examination shall disclose to its satisfaction to be thus defective.

**Exclusions:**

This Warranty Policy does not apply to damages resulting from accident, misuse, abuse or alteration, nor does it apply to limed steam generators, nor does it apply to any consequential damages. Most geographical areas require the use of distilled or demineralized water. Tap water is permissible only with ES Series Steamers. Nor does it apply to Barbrig's®, briquettes, or rods used in gas broilers. Midco's obligation will be the replacement of the product or parts removed.

**Terms:**

Under the terms of this Warranty Policy, models considered portable (devices with cords and plug caps such as EmberGlo Steamers) must be taken or returned to the nearest service provider, transportation prepaid, returned transportation collect. Non-portable units with permanent wiring will be serviced on the customer's premises. Under these terms, Midco agrees, within the terms of this Warranty period, to make all repairs at no charge by the authorized service provider. Labor and mileage charges submitted by any other provider not authorized will be the responsibility of the customer.

**Customer Requirements:**

All charges related to repairs made one (1) year after the date of original installation, during the Warranty period will be the responsibility of the customer. The product registration information is located on the product I.D. plate.

If a part is defective due to workmanship or materials and is removed from the product within the applicable warranty period and returned to Midco in accordance with the following procedure described, Midco will, at its option, either repair or replace the part.

**Call the factory for instructions on returned goods.**

**No equipment may be returned without written authorization from MIDCO. Returned goods must be shipped prepaid to the factory.**

** WARNING: Improper installation and use of this product could result in personal or property injury.**

**TO VALIDATE WARRANTY:  
FILL OUT THE FORM ON THE NEXT PAGE  
AND RETURN TO EMBERGLO**

**Mail: EmberGlo  
4140 W Victoria Street  
Chicago, IL 60646**

**Fax: 773 604 4070**

**Email: [sales@emberglo.com](mailto:sales@emberglo.com)**

## Warranty

Midco® International Inc Limited Warranty Policy  
Exclusions Terms, Customer Requirements and Instructions

All claims should be filed through Warranty Central. Call factory for information (773 604 8700)

*Warranty  
Claims*

*Warranty  
Return Form*

Fill out form and fax to 773 604 4070 or copy and mail to: **EmberGlo** A Division of Midco International  
4140 West Victoria Street

Date of Purchase \_\_\_\_\_

End User Name \_\_\_\_\_

Company Name \_\_\_\_\_

Street & Apt. No. \_\_\_\_\_

City, State, Zip \_\_\_\_\_

Email Address \_\_\_\_\_

Web Address \_\_\_\_\_

Telephone \_\_\_\_\_

Fax \_\_\_\_\_

Gas Broiler     Electric Broiler     Steamer     Accessory

Model Number \_\_\_\_\_

Serial Number \_\_\_\_\_

Installation Date \_\_\_\_\_

Purchased from - Name: \_\_\_\_\_

Address \_\_\_\_\_

City, State, Zip \_\_\_\_\_

