



**DL18SP**



**DL18P**



**DL18DP**

**DL18SP, DL18DP & DL18P**

“Superior *quality* product  
at an *affordable* price !”

## DOUGH SHEETER

### Standard Features

- Compact design, ideal for use in limited space
- Sanitary, heavy duty, all stainless steel welded construction
- Spring loaded scrapers easily removable for cleaning
- Simple handle adjustments for exact uniform dough thickness
- Ergonomic design for easy operation
- Large hopper accepts large pieces of dough
- Convenient all-in-front operation
- Maintenance free drive mechanism
- Drive mechanism is isolated from roller area
- Sanitary plastic precision ground rollers
- 1” (25 mm) sanitary legs with rubber boots
- Will sheet up to 17” (432 mm) diameter
- Sealed ball bearings, permanently lubricated
- Fully adjustable
- One operator can make up to 250 pieces per hour
- ETL & ETL Sanitation listed
- One year parts and labor limited warranty

### OPTIONAL

- Foot switch control for DL18DP
- 220V - 1PH - 50 Hz
- Model conform to requirements of RSST, conforms to the following norms and requirements:
  - EN 954-1 article 6.2.1
  - CSA Z432-04, articles 6.2.1.9.2, 6.2.1.9.3, 6.2.1.9.4, 6.2.3.2, 7.17, 10.2
  - RSST articles 172 à 175, 182, 184, 187, 189, 190, 192

### DL18 series Counter top dough sheeter

The Doyon DL18 series dough sheeter is an efficient one (DL18SP) or two stage (DL18DP & DL18P) machine featuring a front infeed and discharge. Ergonomic design makes it easy and simple to operate.

Pizza and pie shells are made easily with this compact, counter top design that is simple to use. Simply drop a floured dough ball at the top and pick the sheeted dough piece at the bottom.

Sheet dough up to 17” (432 mm) in diameter to a uniform thickness in seconds. One operator can make up 250 pieces per hour .

Simple, fast and economical. Sheet pie crusts or pizza shells up to 17” (432 mm). The DL18 series features large diameter rollers and a Quick Change Index System to quickly change the gap between the dough rollers.

Ideal for: Pizza (up to 17"- 432 mm), Tortillas, Calzones, Focaccia Roti, Pita Bread, Flat Bread

## DIMENSIONS

### DL18DP

20 1/2"W X 13"D X 31 1/2" H  
(520 mm X 330 mm X 800 mm)

Top Rollers: 2" X 10 1/2" (51 mm X 267 mm)

Bottom Rollers: 2" X 18" (51 mm X 457 mm)

### DL18P

22 1/2"W X 13"D X 32 1/4" H  
(570 mm X 330 mm X 820 mm)

Top Rollers: 2" X 10 1/2" (51 mm X 267 mm)

Bottom Rollers: 2" X 18" (51 mm X 457 mm)

### DL18SP

22"W X 10 5/8"D X 13 3/8" H  
(560 mm X 270 mm X 340 mm)

Rollers: 2" X 18" (51 mm X 457 mm)

## ELECTRICAL SYSTEM

120V - 1 PH - 370 Watts - 60 Hz

Heavy duty, maintenance free 1/2 HP motor

## CAPACITY

Sheets from 1oz to 28oz (30g to 800g) of dough

Maximum rollers gap : 13/64" (5 mm)

Up to 250 dough pieces per hour

## Finish

Stainless steel

## SHIPPING WEIGHT

100 lb (45 kg) approximately

Specifications and design subject to change without notice.



Foot switch control for  
DL18DP



Conforms to ANSI/UL std. 763 Conforms to  
Certified to CSA C22.2 no.195 ANS/NSF8

1255, rue Principale  
Linière, Beauce, Québec, Canada G0M 1J0

Telephone : (418) 685-3431 Fax: (418) 685-3948  
Canada : (800) 463-1636 U.S.: (800) 463-4273  
E-Mail : doyon@doyon.qc.ca Internet: <http://www.doyon.qc.ca>

## DL18DP

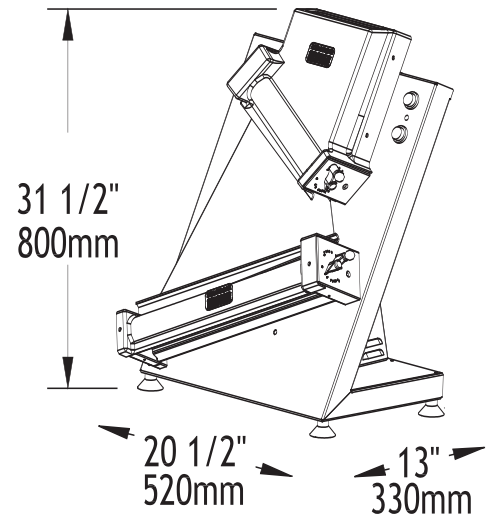

## DL18P

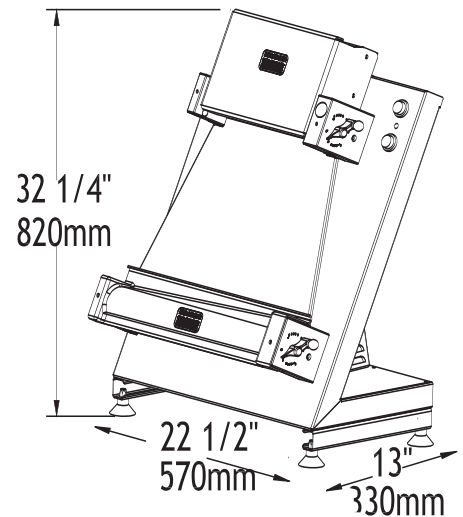

## DL18SP

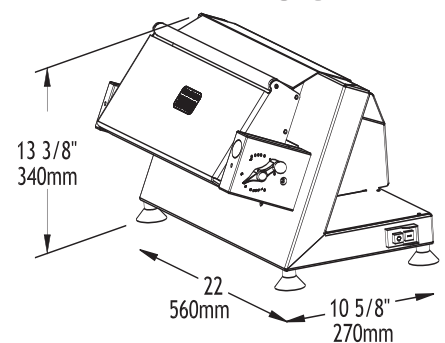

Your local distributor:

