



N225/N227

Self-Contained Drop-In Freezer

Project _____
 Item _____
 Quantity _____
 CSI Section 11400
 Approved _____
 Date _____

N225/N227 Self-Contained Drop-In Freezer

Models

- N225 6 gallon drop-in freezer with stainless steel lid
- 225L 6 gallon drop-in freezer with Lexan® lid
- N227 12 gallon drop-in freezer with stainless steel lid
- 227L 12 gallon drop-in freezer with Lexan® lid



Model N227

Standard Features

- Suitable for ice cream storage
- 18-gauge stainless steel top
- Die stamped top opening with raised edge
- High-density environmentally friendly, Kyoto Protocol Compliant, Non ODP (Ozone Depletion Potential), Non GWP (Global Warming Potential) polyurethane foam throughout unit
- Mechanically cooled 0°F to 5°F tank
- Folding removable cover with external handle
- Models ending in L are standard with a Lexan® lid
- 9' cord and plug
- Environmentally friendly HFC-404A refrigerant
- One year parts and 90 day labor standard warranty

Options & Accessories

- Locking device
 - *220 volt, 50 cycle system
- *Inclusion of this option will alter the electrical specifications of the unit.

Specifications

Model N225 & 225L

Top of 18-gauge stainless steel, has 1.31" (3.3 cm) overhang front to back and 1.25" (3.18cm) right to left, one die-stamped 10.44" (26.5 cm) x 20.69" (52.5 cm) opening with raised edges. Opening is fitted with insulated, folding, lift-off cover. Models ending in L are standard with a Lexan® lid.

Freezer compartment interior is 22-gauge stainless steel and measures 10.81" (27.4 cm) x 22.12" (56.2 cm) x 12.25" (31.1 cm) high. Compartment sides are wrapped with refrigeration lines. Sides and bottom are insulated with high-density closed-cell environmentally friendly, Kyoto Protocol Compliant, Non ODP (Ozone Depletion Potential), Non GWP (Global Warming Potential) polyurethane. Unit is designed to maintain 0° to 5° F (-18°C to -21°C). Cabinet capacity is 6 gallons.

Condensing unit mounted below freezer compartment on 16-gauge steel frame, has 1/5 H.P. rating.

A stainless steel louver, 13" (33 cm) x 25" (63.5 cm), is supplied for field installation. The cutout size for the louver is 11.50" (29.2 cm) x 23" (58.4 cm).

Model N227 & 227L

Top of 18-gauge stainless steel, has 1.31" (3.3 cm) overhang on all sides, two die-stamped openings have raised edges, measure 10.44" (26.5 cm) x 20.69" (52.5 cm), are fitted with insulated, folding, lift-off covers. Models ending in L are standard with a Lexan® lid.

Freezer compartment has 22-gauge stainless steel interior and measures 24.19" (61.4 cm) x 22.12" (56.2 cm) x 12.25" (31.1 cm) high. Compartment sides are wrapped with refrigeration lines. Insulation on sides and on bottom is high-density closed-cell environmentally friendly, Kyoto Protocol Compliant, Non ODP (Ozone Depletion Potential), Non GWP (Global Warming Potential) polyurethane. Unit is designed to maintain 0° to 5° F (-18°C to -21°C). Cabinet capacity is 12 gallons.

1/5 H.P. condensing unit is mounted below freezing compartment on 16-gauge steel frame.

A stainless steel louver, 13" (33 cm) x 25" (63.5 cm), is supplied for field installation. The cutout size for the louver is 11.50" (29.2 cm) x 23" (58.4 cm).



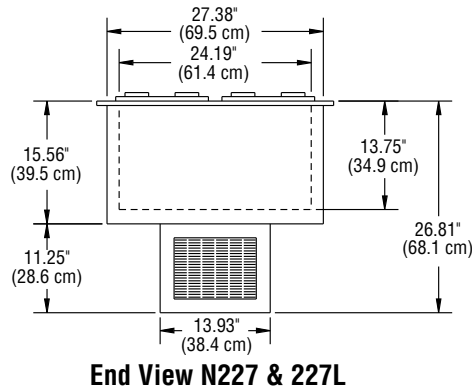
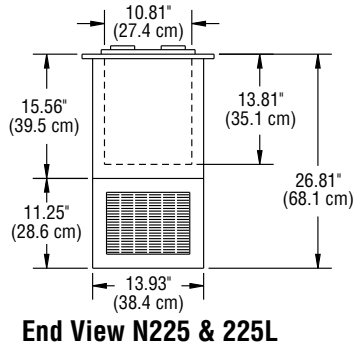
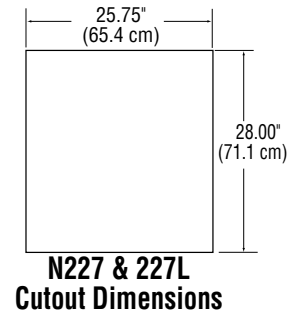
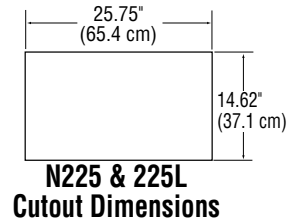
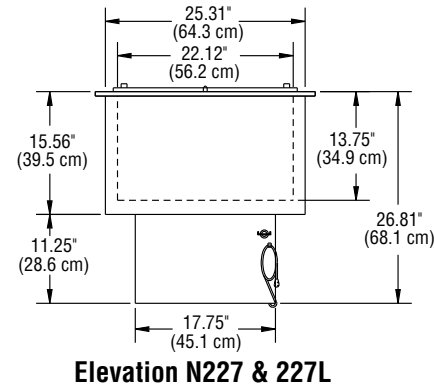
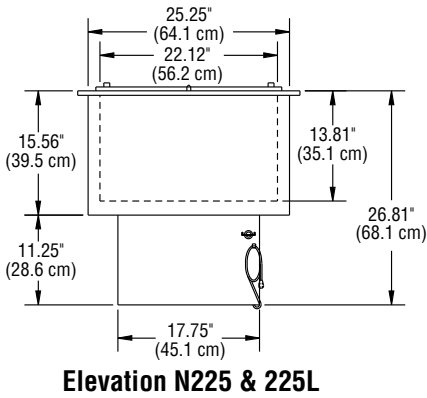
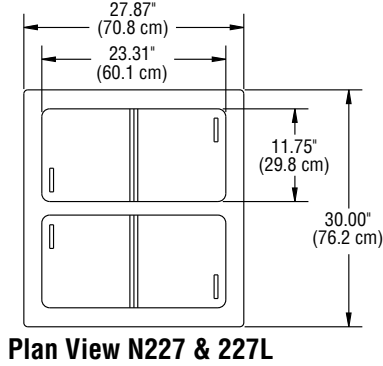
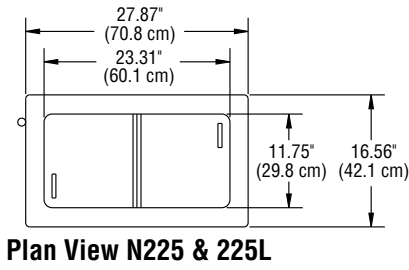

Specifications

Model	Capacity	H.P.	Amps	V/Hz/Ph	Nema Plug	Ship Weight	KWH
N225 & 225L	6 Gallons	1/5	5.3	115/60/1	5-15P	115lbs/52kg	1.82
N227 & 227L	12 Gallons	1/5	5.3	115/60/1	5-15P	191lbs/87kg	2.26