

# PIZZAPRO™

Model No.

# DP3300M

## Creating a RAISED EDGE pizza crust is simple with the DP3300M Electro-Mechanical™ Dough Press

Operation is entirely electro-mechanical which means no noisy compressors or leaky hydraulics to deal with.

Portions size of dough ball and LPMI mold insert dictates size of crust with raised edge.

Safe to operate and clean.

Compact size fits just about anywhere.

Flattens all size pizzas up to and including 18" (46 cm) diameter using various LPMI inserts.

Thickness adjustment provided.

Heat potential for upper platen helps cold dough flow faster.



Listed.

<b>ON/OFF Switch</b>	Yes	<b>Electrical Data</b> 120v/60hz 1450w/12.5amps 230v/50-60hz 1450w/6.0amps
<b>Automatic Timer</b>	Yes	
<b>Adjustable Thickness</b>	Yes	
<b>Temperature Control</b>	Yes	<b>Shipping Weight's</b> 200 lbs. / 91 kgs.
<b>Maximum Heat</b>	0-200°F	

Includes 72" cord and NEMA approved plug.

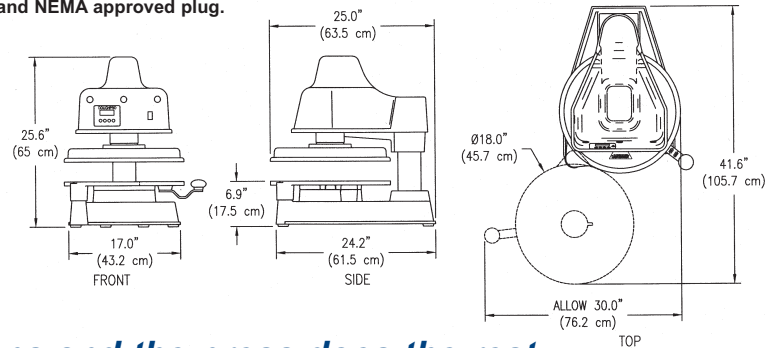

DP3300M Shown with LPMI Insert.

Please see various LPMI molds in Accessories. (Lower Platen Mold Insert)

Simply press two buttons and the press does the rest.



After allowing upper platen to reach desired temperature, swing out lower platen and place pre-portioned ball of dough in approximate center and swing closed. An approved lubricant/release agent such as olive oil or DOUGHPRO's Cookware Food Release Spray # DPCC1 applied to the top of the dough ball will greatly improve the pressing operation.



Set the desired time cycle, push down both left and right piston activation buttons, hold until resistance is felt and release. A beeping sound will be heard when it reaches 0.



Wait for the automatic pressing cycle to finish. Pull out lower platen and place flattened crust on screen, disc or pan.

Factory shipped with an 18" LPMI mold insert.

Specifications, Details and Prices are subject to change without prior notice. Please call for current pricing.

DOUGHPRO

20281 Harvill Ave, Perris, CA 92570

(951) 657-0379 (800) 624-6717 Fax (951) 657-4594

# DOUGHPRO®

STEARNS PRODUCT DEVELOPMENT CORPORATION

Website: [www.doughpro.com](http://www.doughpro.com) E-Mail: [info@doughpro.com](mailto:info@doughpro.com)