

PIZZAPRO™

Model No.

DP1300

AUTOMATIC PIZZA PRESS

With skilled labor becoming even more scarce and home deliveries calling for faster production, the DP1300 automatic pizza press answers the call.

How fast is the DP1300? It varies, but use these figures as a guide:

- Warm dough, moderate to high yeast. 2 seconds
- Cold dough, moderate yeast 4-6 seconds
- Cold dough, small amount of yeast 8 seconds

- Press cycle timer (regulates the pressing cycle).
- Emergency release button (Disengages press cycle).
- Safety interlock switch, prevents pre-cycle activation.
- Air filter with automatic self-evaporating drain-off.
- Flattens all size pizzas up to and including 18" (46 cm) diam.
- Thickness adjustment crank provided.
- Portions size of dough ball dictates size of crust.
- Heat potential for upper platen helps cold dough flow faster.



Listed.

Requires remote or self contained compressor (DP1500C)

ON/OFF Switch	Yes	Electrical Data 120v/60hz 1450w/12.5amps 240v/50-60hz 1560w/6.5amps
Automatic Timer	Yes	
Adjustable Thickness	Yes	
Temperature Control	Yes	Shipping Weight's 200 lbs. / 91 kgs.
Maximum Heat	0-200°F	

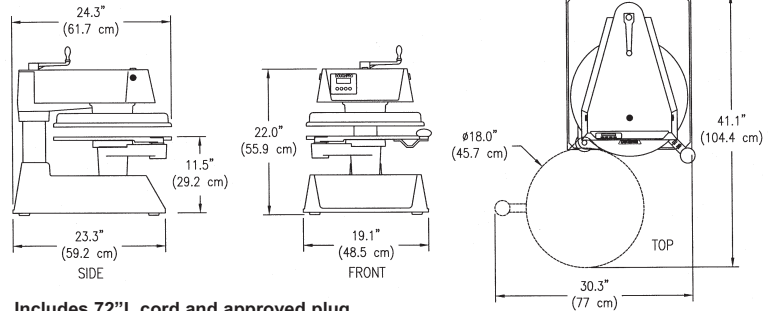

Includes 72" L cord and approved plug.

Set the desired time, press two buttons and the press does the rest



After allowing upper platen to reach desired temperature, swing out lower platen and place pre-portioned ball of dough in approximate center and swing closed. An approved lubricant/release agent such as olive oil or DOUGHPRO's Cookware Food Release Spray # DPPC1 applied to the top of the dough ball will greatly improve the pressing operation.



Set the desired time cycle. Push down both left and right compression activation buttons, hold until resistance is felt and release. The DP1300 will automatically release when the time cycle is finished.



Open platen and place flattened crust on screen, disc or pan. Now you're ready for make-up and baking.

Specifications, Details and Prices are subject to change without prior notice. Please call for current pricing.

DOUGHPRO
20281 Harvill Ave, Perris, CA 92570
(951) 657-0379 (800) 624-6717 Fax (951) 657-4594

DOUGHPRO®
STEARNS PRODUCT DEVELOPMENT CORPORATION
Website: www.doughpro.com E-Mail: info@doughpro.com