

# PIZZAPRO™

Model No.

# DP1100M

## Creating a RAISED EDGE pizza crust is simple with the DP1100M !

Manually operated, no motor or compressors required.

Press a raised edge using special mold inserts.  
Safe to operate and clean.

Compact size fits just about anywhere.

Flattens all size pizzas up to and including 18" (46 cm) diameter using various LPMI inserts.

Thickness adjustment provided.

Portions size of dough ball and LPMI mold insert dictates size of crust with raised edge.

Heat potential for upper platen helps cold dough flow faster.

Fast cleaning since no flour required.



**DP1100M Shown with LPMI Insert.**

*Please see various LPMI molds in Accessories. (Lower Platen Mold Insert)*



Listed.

<b>ON/OFF Switch</b>	Yes	<b>Electrical Data</b> 120v/60hz 1425w/11.9amps
<b>Automatic Timer</b>	No	
<b>Adjustable Thickness</b>	Yes	240v/50-60hz 1425w/5.93amps
<b>Temperature Control</b>	Yes	<b>Shipping Weight's</b> 190 lbs. / 79 kgs.
<b>Maximum Heat</b>	0-200°F	

Includes 72" cord and approved plug.

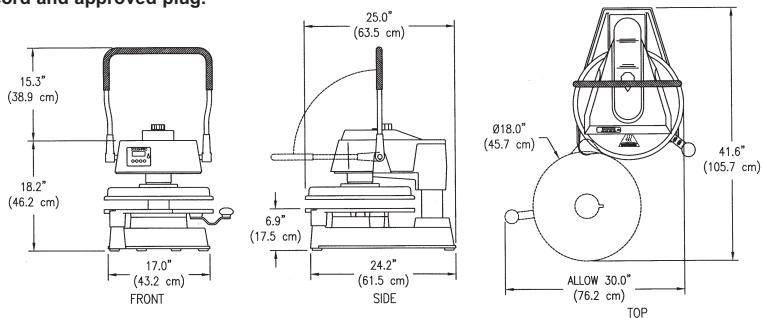

## Operating the DP1100M is simple, requiring only minutes of instruction:



After allowing upper platen to reach desired temperature, swing out lower platen and place pre-portioned ball of dough in approximate center and swing closed. An approved lubricant/release agent such as olive oil or DOUGHPRO's Cookware Food Release Spray # DPPC1 applied to the top of the dough ball will greatly improve the pressing operation.



Once your desired time is set pull down on handle and hold applying pressure. The digital control will count down, a beeping sound will be heard when it reaches 0.



Lift up handle, open platen and place flattened crust on screen, disc or pan. Now you're ready for make-up and baking.

Factory shipped with an 18" LPMI mold insert.

*Specifications, Details and Prices are subject to change without prior notice. Please call for current pricing.*

DOUGHPRO

20281 Harvill Ave, Perris, CA 92570

(951) 657-0379 (800) 624-6717 Fax (951) 657-4594

# DOUGHPRO®

STEARNS PRODUCT DEVELOPMENT CORPORATION

Website: [www.doughpro.com](http://www.doughpro.com) E-Mail: [info@doughpro.com](mailto:info@doughpro.com)