

## Mobile Tortilla Preparation Station

*Press and grill tortillas, all in one station, without leaving your work area.*

Here's a tortilla production/display counter when combined with our tortilla grills and dual heat presses results in a high volume mini-production plant.

It's so simple to operate; even your least skilled employees will be making world class tortillas after only a few minutes of simple instructions. Here's how it works:

**Step 1:** Dough balls are pre-portioned and stored in (8)18"x26" trays located beneath the **DPTPS**.

**Step 2:** Using either our model **DP2000** or **DP6208** tortilla press, simply lay down the dough ball(s) and press it flat.

**Step 3:** Place the flattened tortillas on either our model **TW2025** or **TW1520** grill. The tortillas will finish in a matter of minutes and then they can be served hot **FRESH** off the grill.



(Shown with TW2025 & DP2000 & tray's not included)

Shown with TW2025, DP2000 & Sheet Pans. (not included)

- Store 8 full size 18" x 26" sheet pans.
- Large 2 bin storage space.
- Can hold **ANY COMBINATION** of Tortilla or Pizza presses and grills.
- **Shipping Weight:** 145 lbs.
- **Custom configurations can be built for your specific requirements.**

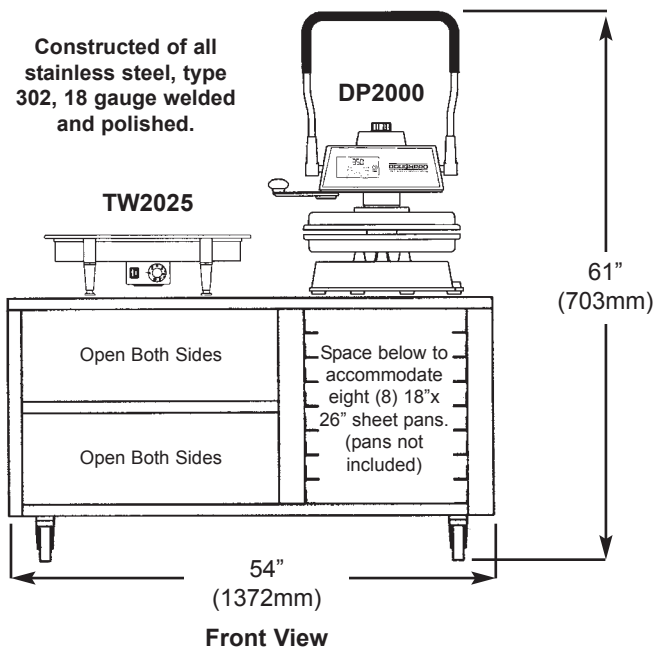
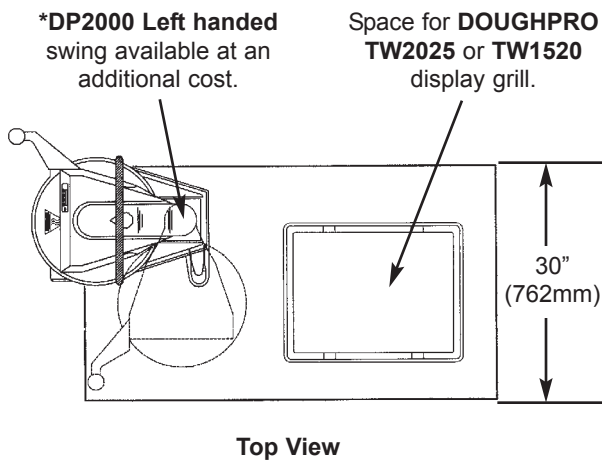

Specifications, Details and Prices are subject to change without prior notice. Please call for current pricing.