

Crimsco Inc. Healthcare Meal Delivery Systems



Model CRS

Room Service Delivery Cart
For 14" x 18" and 15" x 20" trays



Standard Features

- ▼ One piece Removable Tray Slides
- ▼ Flush recessed door pull
- ▼ Heavy duty 5" casters
- ▼ Magnetic door closure
- ▼ Complete stainless steel construction
- ▼ Super duty reinforced base
- ▼ 270 degree door swing
- ▼ Full perimeter bumper
- ▼ 12 gauge hinges
- ▼ (3) Sided top rail

Options

- ▼ Pass Through Model

Durability. Flexibility. Reliability

- Heavy duty, sealed bearing casters, low profile, slim line design insure easy maneuverability
- Long lasting construction-built entirely with stainless steel
- Full perimeter bumper protects the entire cart from damage
- One piece shelving allows for easy cleaning and loading of multiple tray sizes
- Top rail allows for items to be transported on top of unit
- 270 degree door swing is user friendly and saves space
- Attractive design
- Economically priced



Crimsco a Division of **ITW** FEG
7737 N 81st Street Milwaukee, WI 53223 USA
414-702-8972 / 800-367-8413 / Fax 414-354-2821



Crimsco Inc. Healthcare Meal Delivery Systems



Model CRS

Room Service Delivery Cart

For 14" x 18" and 15" x 20" trays

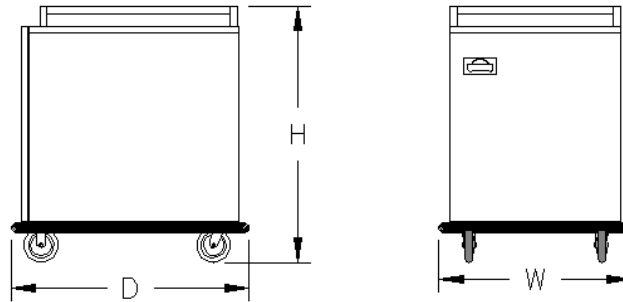

Model	Capacity	Width	Depth	Height	Weight	Electrical	NEMA	Casters
CRS-10	(10) 14" x 18"	28"	34.5"	42.25"	120 lbs	N/A	N/A	5"
	(10) 15" x 20"							
CRS-10-PT	(10) 14" x 18"	28"	34.5"	42.25"	130 lbs	N/A	N/A	5"
	(10) 15" x 20"							

Specifications

Construction: Stainless steel construction, double pan base with reinforced internal channels

Bumper: Continuous wrap around aluminum (dove-tail) designed bumper complete with (secure fit) non-marking vinyl insert

Doors: Double pan design, fully insulated, 270 degree swing, 12 gauge hinges, recessed door pulls

Casters: 5" super duty polyurethane casters mounted to 1/4 inch mounting plates. (2) swivel with brakes (2) rigid.

Casters equipped with mounting plate shall be secured to reinforced base channel with 3/8" carriage bolts

Racking: Universal one piece shelving

Tray configuration: 5 level, (2) trays deep with 6" spacing.

Note: in line with its policy to continually improve its products, Crimsco Inc. reserves the right to change materials and specifications without notice

Crimsco a Division of **ITW** FEG
 7737 N 81st Street Milwaukee, WI 53223 USA
 414-702-8972 / 800-367-8413 / Fax 414-354-2821

