

QUIK THERM™ 12 KW RETHERM OVEN MODEL RO-151-FUA-18D

FEATURES AND BENEFITS:

- Fully insulated Retherm Heat-N-Hold oven designed for both reconstituting precooked foods and slow roasting.
- Slow convected air system promotes natural browning for flavor and seals in natural juices.
- Full 12000 Watts of power allows for rethermalization of prepared meals or bulk items. Maximum temperature 350°F. (176.5°C.).
- Standard solid state electronic control with large, clean, easy-to-read and operate LED digital display to ensure holding at precise food temperatures.
- 18 factory or field programmed retherm & hold cycles. Each programmed menu can be customized for exact time and temperature needs.
- Standard with probe cooking, includes one 1-1/2" food temperature probe.
- Non-venting oven, permitted by most local codes, provides easy, inexpensive installation.
- Stainless steel construction throughout for ease of cleaning.
- Smooth interior coved corners prevent food particle/grease buildup.
- Field reversible insulated Dutch doors prevent temperature loss. Silicone door gaskets for proper seal. High temperature ceramic magnetic latches for "easy open" and security during transport.
- Safety conscious anti-microbial latches protect against spreading germs. Standard with right hand hinging; left hand hinging available upon request.
- Recessed push/pull handles on both sides prevent damage to walls; allows easy maneuvering.
- Chrome plated wire universal angles accommodate a large variety of pan sizes on adjustable 1-1/2" spacing. Supplied with 18 sets of angles.
- Heavy duty 5" swivel casters, two with brakes. Provides mobility when fully loaded.

POWER UNIT OPTIONS:

12,000 Watts, 208 Volts, 3 Phase, 60 Hz.

12,000 Watts, 240 Volts, 3 Phase, 60 Hz.



RO-151-FUA-18D

ACCESSORIES and OPTIONS (Available at extra cost):

- 6" Food Temperature Probe
- Security Panel for Controls
- Tempered Glass Door Windows
- Key Lock Latches
- Wire Grids
- Extra Universal Angles
- Perimeter Bumper
- Corner Bumpers
- Floor Lock (for use with 5" casters)
- Various Caster Options
- HACCP Documentation (built in USB port)

See page E-10 for accessory details.

RO-151-FUA-18D

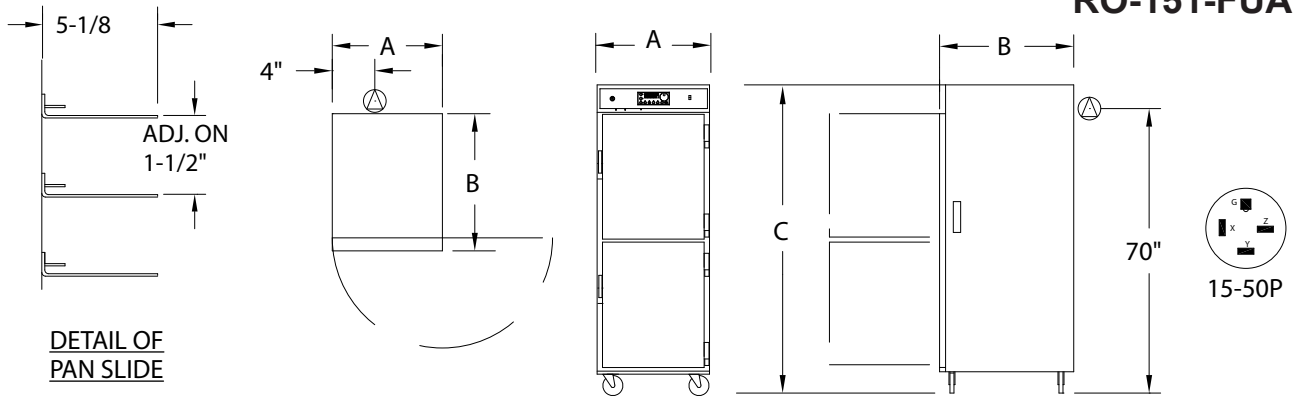

CRES COR MODEL NO.	PAN			DIM "A"	DIM "B"	DIM "C"	INSIDE DIMENSIONS				WEIGHT ACT.
	CAP/ ANGLES	SIZE		WIDTH	DEPTH	HEIGHT	WIDTH	DEPTH	HEIGHT		
RO-151-FUA-18D	18 SETS	SEE NOTE BELOW	IN	28-3/4	37-3/4	73-11/16	21-3/4	26-7/8	58	LBS	392
			MM	730	960	1875	555	685	1475	KG	178

NOTES: 1. Pan sizes 22" x 20" (560 x 510) Roast & Bake Pans, 10" x 20" (255 x 510) Roast & Bake Pans, 18" x 26" (460 x 660) Bun Pans, 14" x 18" (355 x 460) Service Trays, 12" x 20" (305 x 510) Steam Table Pans.
Refer to Pan Size Chart at end of section.

2. When ordering bumpers, add 2" to overall dimensions.

ALL CONSTRUCTION IS RIVETED, WELDED AND FINISHED.

CABINET:

- Body: 22 ga. stainless steel.
- Reinforcement: Internal framework of 18 ga. stainless steel.
- Insulation: Fiberglass, thermal conductivity (K factor) is .23 at 75°F. 1-1/2" in back wall, doors, base; 2" in side walls.
- Air tunnel: 22 ga. stainless steel, lift-out type, mounted on sides.
- Interior coved corners.

BASE:

- One piece construction, .125 aluminum.
- Casters: 5" dia., swivel, modulus tires, 1-1/4 wide, load cap. 250 lbs. each, temp. range -45°/+180°F. Delrin bearings. Front casters equipped with brakes.

DUTCH DOORS:

- Field reversible.
- Formed 22 ga. stainless steel.
- Latches: Chrome plated steel, high temperature ceramic magnetic type.
- Hinges: Heavy duty chrome plated steel.
- Gaskets: Perimeter type, silicone.
- Pan stops: Embossed.

PAN SLIDES:

- Chrome plated wire universal angles (.306 dia.), mounted on lift-out posts.
- 18 sets of angles; adjustable on 1-1/2" centers.

POWER REQUIREMENTS AVAILABLE:

- 12,000 Watts, 208 Volts, 60 Hz., 3 phase, 50 Amp. service.
- 12,000 Watts, 240 Volts, 60 Hz., 3 phase, 50 Amp. service

HOT UNIT COMPONENTS:

- Thermostat (retherm/hold): Solid state digital control, 140°F to 350°F (176.5°C).
- Switch: ON-OFF push button type.
- Power cord: Permanent, 10 ft., 12/3 ga. with 15-50 plug.
- Heaters: 2000 Watts each.
- Switch: (1) Air volume.
- Blower motors: (6).
- Vent fans: (2).
- Fuses: (2) 6 Amp.
- Probe: (1) 1-1/2", stainless steel.

INSTALLATION REQUIREMENTS:

- Check local vent hood codes for mobile Roast-N-Hold ovens.

SHORT FORM SPECIFICATIONS

Cres Cor Retherm Heat-N-Hold Oven Model RO-151-FUA-18D. 20 ga. stainless steel, recessed control panel. Cabinet and Dutch doors 22 ga. stainless steel; stainless steel internal frame; coved corner interior. Fiberglass insulation in sides 2"; back, doors and base 1-1/2". High temperature anti-microbial magnetic latches. (18) sets universal angles for multiple pan sizes and spacing. One piece base .125 aluminum. 5" swivel modulus casters, Delrin bearings. Load capacity 250 lbs. each. 12,000 Watts, _____ Volts, 60 Hz., 3 Phase. 2-Year Parts / 1-Year Labor warranty. Provide the following accessories: _____ .



5925 Heisley Road • Mentor, OH 44060-1833
Phone: 877/CRESCOR • Fax: 440/350-7267
www.crescor.com

© Crescent Metal Products, Inc. 2011 All rights reserved.

In line with its policy to continually improve its products, CRES COR reserves the right to change materials and specifications without notice.

Litho in U.S.A.